

A TWO-STAGE SPLITRING-RFQ FOR HIGH CURRENT ION BEAMS AT LOW FREQUENCIES*

M. Baschke, A. Schempp, H. Podlech,
 IAP, Goethe-University, Frankfurt am Main, Germany

Abstract

For several accelerator projects RFQs are the first stage of acceleration. To reach high intensities a new Splitring-RFQ is investigated. Not only a high current and high beam quality/brilliance should be achieved, also a good tuning flexibility and comfort for maintenance are part of the study. The RFQ will consist of two stages with 27 MHz and 54 MHz to accelerate ions with an A/q of 60 up to energies of 200 keV/u. RF simulations with CST MWS have been performed to obtain the quality factor, shunt impedance and voltage distribution as well as tuning possibilities. The results and the status of the project will be presented.

DIFFERENT DESIGN STUDIES

Following the first general design studies with three different design concepts [1] additional simulations with detailed models were performed to evaluate resonator parameters as well as advantages and disadvantages.

The best results were achieved with the heart shaped design. This is used for following research.

RESONATOR PARAMETERS

A nine-stems and a ten-stems model were created with the heart shaped design (Fig. 1) to observe the behaviour of the resonator parameters for a complete accelerator compared to the short model. As shown in Table 1 the parameter values do not differ significantly. Especially with an even and odd number of stems it does not make a difference. Classical 4-rod-RFQs always need an even number of stems, because two stems form one RF cell while with the splitting geometry one RF cell contains only one stem. This leads to more flexibility for the accelerator length and therefore for the beam dynamics, too.

Table 1: Resonator Parameters

# stems	resonance frequency [MHz]	quality factor	R _p [kΩm]
2	27.02	10700	1380
9	27.07	11210	1387
10	27.05	11250	1377

The enlarged model of the RFQ with a length of approximately 450 cm respectively 500 cm and a width and height of each about 100 cm has an overall flatness of less than ± 3% (Fig. 2).

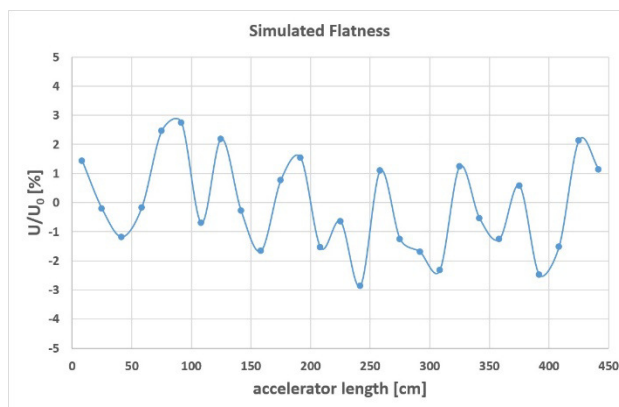

Figure 2: Flatness of the RFQ.

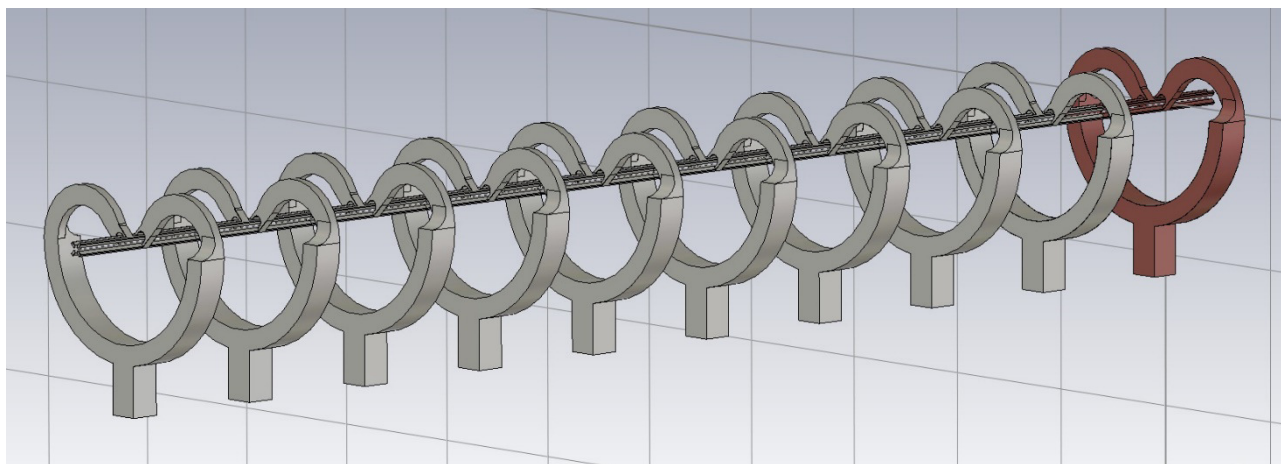

Figure 1: A nine-stems (without red one) and a ten-stems model (with red one) of the heart shaped Splitring-RFQ.

* Work supported by HIC for FAIR, BMBF Contr. No. 05P15RFRBA

Content from this work may be used under the terms of the CC BY 3.0 licence © 2018. Any distribution of this work must maintain attribution to the author(s), title of the work, publisher, and DOI.

TUNING

For tuning two options were tested: tuning blocks mounted sideways of (marked red in Fig. 3) and inside the (marked blue in Fig. 3) main ring. The “blue” tuning option allows a frequency increase of about 4 MHz while the “red” one does an increase of about 2 MHz, each with marginal influence on quality factor and shunt impedance.

The problem with this tuning options is, that it is not possible to do a directly continuously shift. Instead every step needs a new tuning block. This is possible but not very feasible.

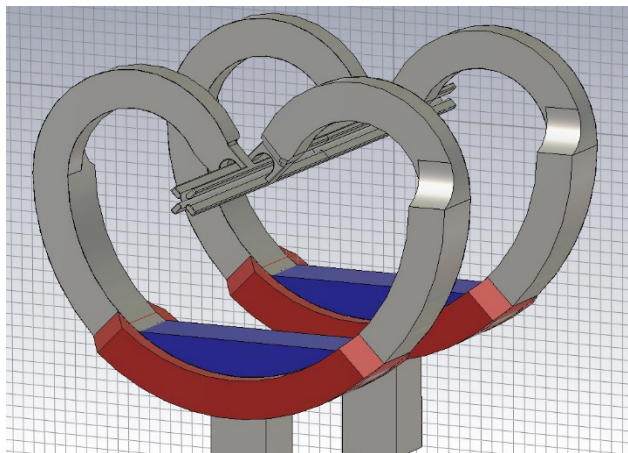

Figure 3: Tuning options.

54 MHz MODEL

The second stage was planned as a 54-MHz-RFQ. The results of structure simulations (Fig. 4) have shown the possibility to use a splitting geometry for this frequency, but with a much lower shunt impedance (quality factor of 10500, shunt impedance of 670 kΩm). But most notably beam dynamics simulations have shown that because of the lower focusing strength at 54 MHz a very high voltage would be needed for high beam currents. Around 200 kV would lead to sparking and a breakdown of the E-field as indicated by a Kilpatrick factor of 6.

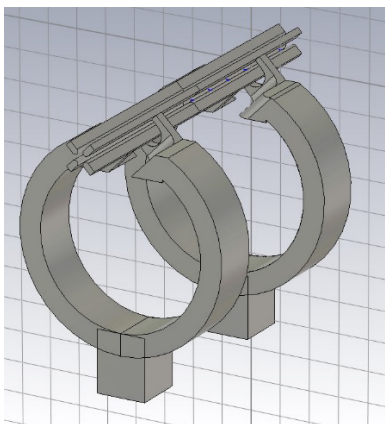

Figure 4: 54 MHz model of Splitring-RFQ.

ANOTHER ALTERNATIVE DESIGN

During development and due to tuning difficulties with the former designs another design concept was created. The Funky-RFQ is a mixture of a classical 4-rod-RFQ and a Splitring-RFQ (Fig. 5). It consists of mainly straight stems, so that classical tuning plates could be used. But as typically for the splitting geometry all four electrodes are mounted at every stem point along the beam axes. First simulations show feasible results for a frequency of 27.1 MHz with quality factor $Q = 11400$ and a shunt impedance of $RP = 1500 \text{ k}\Omega\text{m}$.

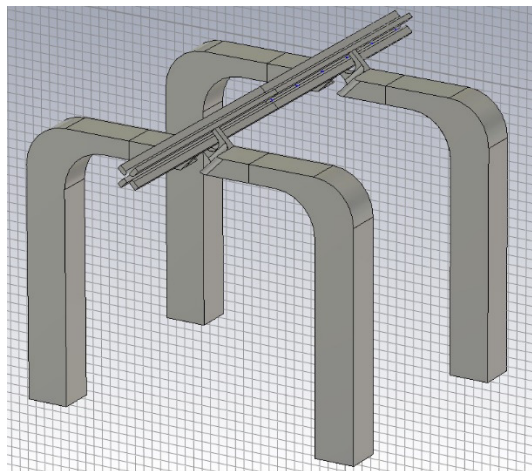

Figure 5: First model of a Funky-RFQ.

CONCLUSION

Detailed simulations were performed to improve the results for resonator parameters followed by test simulations for a possible complete accelerator structure. As shown the enlargement from a short model does not affect the observed parameters.

Next steps will be to prove the new Funky-RFQ idea including tuning options as well as mechanical stability of all concepts. Then a decision has to be made on one design concept to create a real model for determining the features in reality.

Instead of the 54-MHz-RFQ another 27-MHz-RFQ is now planned as second step for acceleration. Beam dynamics simulations are performed for both RFQs by C. Zhang from GSI (Darmstadt).

REFERENCES

- [1] M. Baschke *et al.*, “Investigation of a Splitring RFQ for High Current Ion Beams at Low Frequencies”, in *Proc. IPAC’17*, Copenhagen, Denmark, May 2017, paper TUPAB148, pp. 1680-1681.