

# DESIGN A HIGH POWER PULSE TRANSFORMER FOR C-BAND KLYSTRON MODULATOR\*

Y. F. Liu<sup>1†</sup>, M. Gu, Q. B. Yuan, X. X. Zhou, Y. H. Wu, Z. H. Chen,  
 Shanghai Institute of Applied Physics, 201800 Shanghai, China

<sup>1</sup>also at University of Chinese Academy of Sciences, 100039 Beijing, China

## Abstract

Shanghai soft X-ray Free Electron Lasers (SXFEL) used C-band accelerator structure to accelerate electrons at SINAP (Shanghai Institute of Applied Physics). 50MW C-band klystron and 110MW modulator are used to provide power supply for accelerator structure. In order to meet the modulator-klystron demands, a reliable and stable high power pulse transformer is indispensable. In this paper, the key design points for the high voltage pulse transformer are presented. The methods of shortening rise time and diminishing flattop droop are highlighted.

## INTRODUCTION

The main requirement for driving the klystron are peak voltage 350KV, peak current 320A, 10Hz repetition rate and 6 micro second pulse width (FWHM) with 3 micro second flat-top [1]. To meet the requirement of 50MW C-band klystron, an optimized high power transformer were developed. The major specification of the pulse transformer is listed in Table 1.

Pulse transformer is a significant component that is used for transmitting pulse waveform and power. Simple schematic diagram and the waveform in the secondary coil of pulse transformer is shown in Fig. 1. It is a good design for a pulse transformer with faster rise time, longer flattop width, smaller flattop droop and smaller flattop oscillation. Excellent transmission performance depends not only on the parameter of pulse transformer itself but also on the parameter of PFN (pulse forming network) and klystron load.

So when we design a pulse transformer we need consider both of the transformer and the klystron modulator. In this paper, the background overview and main specification of high power pulse transformer are presented [2]. The equivalent circuit and distribution parameter of high power pulse transformer are analysed and optimal design methodology is summarized. Meanwhile, relevant experiments results are given.

\* Work supported by the National Natural Science Foundation of China (No. Y715221061) and the National Key Research and Development Program of China (NO.614103061).

† email address liuyongfang@sinap.ac.cn

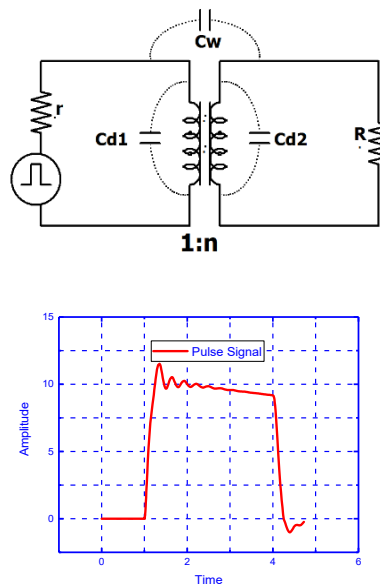

Figure 1: Simple schematic diagram and waveform in secondary coil of pulse transformer.

Table 1: Major Specification of Pulse Transformer

Primary	
Beam voltage	22 kV
Beam current	5100A
Rise time (5-95%)	0.5 us
Fall time (95-5%)	0.5 us
Flattop (95-95%)	5.5us
FWHM (50-50%)	6us
Repeat frequency	10 Hz
Secondary	
Beam voltage	350kV
Beam current	320A
Rise time (5-95%)	0.9 us
Fall time (95-5%)	1.2 us
Flattop (98-98%)	3 us
Flattop ripple	0.25%
Flattop droop	2%

## MODELING ANALYSIS

### Electrical Equivalent Circuit

The electrical equivalent circuit of a step-up pulse transformer is shown as Fig. 2.

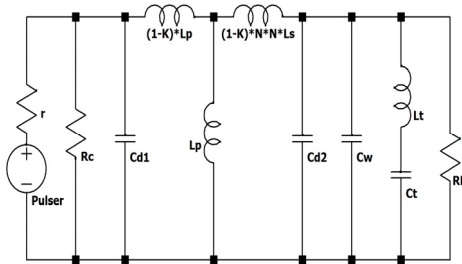

Figure 2: Equivalent circuit of a step-up pulse transformer.

$R_c$  denotes core loss resistance, such as Hysteresis loss and Eddy current loss.  $r$  denotes resistance of pulse generator source.  $K$  is coupling coefficient between primary and secondary ( $K=1$  for ideal).  $C_{d1}$  and  $C_{d2}$  are winding line distribution capacity.  $C_w$  denotes stray capacitance between primary and secondary winding.  $L_p$  denotes primary inductance.  $L_s$  denotes secondary inductance.  $R_L$  denotes load impedance.  $N$  denotes step-up ratio of pulse transformer.  $C_t$  denotes capacitance between primary winding and ground.  $L_t$  denotes charging inductance connected with  $C_t$  in series.

### Shorten Rise Time

Generally, we can neglect the effect of  $R_c$ ,  $L_p$ ,  $L_t$  and  $C_t$  during rise leading edge analysis [3]. In this case, the equivalent circuit of pulse transformer is showing as Fig. 3.

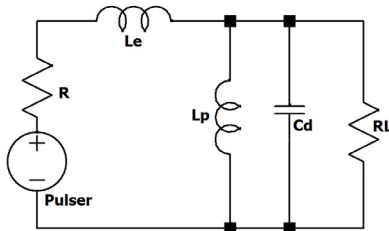

Figure 3: Equivalent circuit used to analysis rise time.

Rise time is determined by leakage inductance and distributed capacitance [4-6]. It can be given by the following equation (1).

$$T_r \propto \sqrt{L_e C_d} \quad (1)$$

Figure 4 shows the waveform with different number of  $L_e$  and  $C_d$ . As can be seen from the figure, for a given value of  $C_d$ , larger  $L_e$  makes slower rise time and for a given value of  $L_e$ , smaller  $C_d$  brings faster rise time and smaller overshoot.

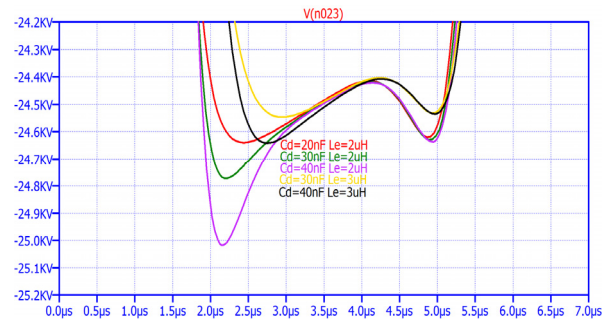

Figure 4: Waveform with different number of  $L_e$  and  $C_d$ .

$L_e$  can be calculated by equation (2). It also can be easily measured by a LCR meter.

$$L_e = \frac{\mu_0}{2} * \frac{C_L * d * N_p^2}{L_c} \quad (2)$$

Where  $\mu_0$  is the permeability of vacuum ( $4\pi \times 10^{-7} \text{H/m}$ ).  $C_L$  is one turn length of primary winding.  $d$  is distance between primary and secondary winding.  $L_c$  is secondary coil height.  $N_p$  is primary winding turns.

We can choose effective tactics to reduction leakage inductance, such as using closed core, cone-shape windings, and close bifilar winding and so on. Leakage inductance is 2.25uH for calculate and 2.3uH for measurement.

Distributed capacitance include distribute capacitance between primary and secondary winding and distribute capacitance about klystron. Total distributed capacitance is 40nF which is measured by LCR meter.

### Flattop Droop and Primary Inductance

Flattop droop is determined by primary inductance [7-9]. We can use the following circuit (Fig. 5) to analysis flattop droop.

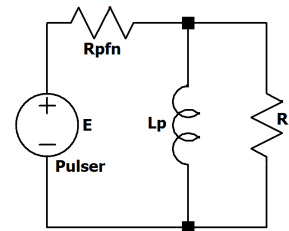

Figure 5: Equivalent circuit used to analysis flattop droop.

The minimum value of primary inductance  $L_p$  is calculated as equation (3)

$$L_p \geq \frac{t * R_L * R_{PFN}}{(R_L + R_{PFN}) * \ln(\frac{1}{1-D})} \approx \frac{t * R_L * R_{PFN}}{(R_L + R_{PFN}) * D} \quad (3)$$

Figure 6 shows the flattop droop simulation result with different primary inductance in C band klystron modulator design.

Content from this work may be used under the terms of the CC BY 3.0 licence (© 2018). Any distribution of this work must maintain attribution to the author(s), title of the work, publisher, and DOI.

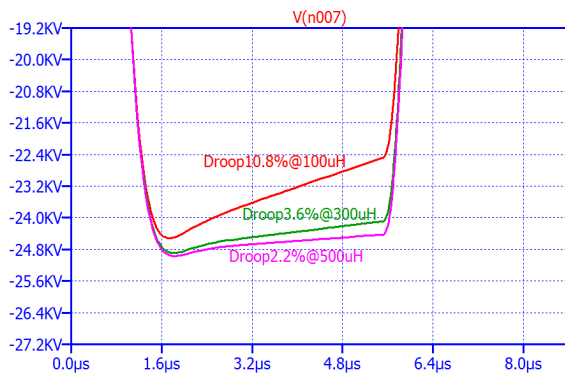

Figure 6: Flattop droop with different primary inductance.

### TEST RESULT

Figure 7 shows the picture of pulse transformer after fabricated. The transformer is placed in a metallic tank filling with transformer oil which is used as insulator and coolant. After the system Assembly, experimental study was carried out. Figure 8 shows the measured output waveform. The waveform is obtained by a precise high voltage divider which divide ratio is 1:10450. Peak voltage and current achieve 380KV and 368A compared with the design numbers of 350KV and 320A. Rise and fall time also faster than design parameters. Due to fast rise and fall time, the pulse transformer use smaller full width at half maximum time to achieve 3us flattop width. Table 2 summarizes the test parameters of output waveform of pulse transformer.



Figure 7: Picture of pulse transformer.

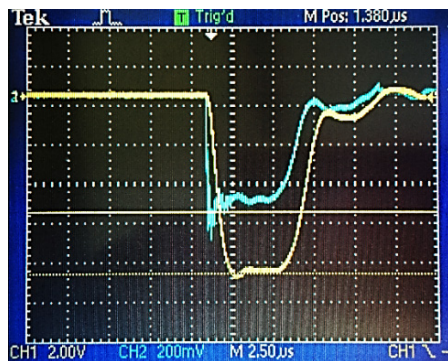

Figure 8: The measured waveform; the green one is primary pulse waveform, and the yellow one is secondary pulse waveform.

Table 2: Measured Parameters of Secondary Waveform

ITEMS	VALUE
Beam voltage	380KV
Beam current	368A
Rise time	0.8us
Fall time	2.3us
FWHM	5.6us
Flattop (98%-98%)	3.1us

### CONCLUSION

Pulse transformer as a key technology for C-band accelerating structure has been studied in SINAP. We use some detailed equivalent circuit to analysis the behaviour of pulse transformer, especially for shorting rise time and reducing flattop droop. It was indicated by the result of experiments that the pulse transformer met the requests of practical target. The circuit model and analysis method can be used to make further study of more high voltage X-band klystron pulse transformer.

### ACKNOWLEDGMENTS

We would like to thank Lin Liu, Huaitian Li and other staff members at MV Company for their supports with ideal and discussion.

### REFERENCES

- [1] Z. Zhao et al., "Status of the SXFEL Facility", *Appl. Sci.*, vol. 7, no. 6, p. 607, 2017.
- [2] Zhang Z, Tan, X, "Review of High Power Pulse Transformer Design", *Physics Procedia*, vol. 32, no. 33, p. 566, 2012.
- [3] Wang Y et al., "Optimal Design and Experimental Study of Pulse Transformers With Fast Rise Time and Large Pulse Duration", *IEEE Trans. on Plasma Science*, vol. 42, no. 2, p. 300, 2014.
- [4] Pan F et al., "Design Procedure of the Leakage Inductance for a Pulse Transformer Considering Winding Structures", *IEEE Trans. on Plasma Science*, vol. 45, no. 9, p. 2504, 2017.
- [5] S. Candolfi et al., "Hybrid design optimization of high voltage pulse transformers for Klystron modulators", *IEEE Trans. on Dielectrics & Electrical Insulation*, vol. 22, no. 6, p. 3617, 2016.
- [6] S. Candolfi et al., "Evaluation of insulation systems for the optimal design of high voltage pulse transformers", in *Proc. 2014 IEEE Power Modulator and High Voltage Conference*, Santa Fe, NM, USA, June 2014, pp. 557-560, doi:10.1109/IPMHVC.2014.7287336
- [7] S. Blume et al., "Design and Optimization Procedure for High-Voltage Pulse Power Transformers", *IEEE Trans. on Plasma Science*, vol. 43, no. 10, p. 3385, 2015.
- [8] A. Baktash, A. Vahedi, "Design of a Wound Core Pulse Transformer Using Multiobjective Optimization Method", *IEEE Trans. on Plasma Science*, vol. 43, no. 3, p. 857, 2015.
- [9] Zhang Z et al., "Compact megavolt pulse transformer with inner magnetic core and conical secondary windings", in *Proc. IEEE Pulse Power Conference*, Austin, TX, USA, May 2015, p. 1, doi:10.1109/PPC.2015.7296978