

A NOVEL HIGH STEP-DOWN DC-DC CONVERTER WITH ISOLATED TRANSFORMER AND SWITCHED CAPACITOR TECHNIQUES FOR CORRECTOR MAGNET BULK POWER IN TAIWAN PHOTON SOURCE

Y. S. Wong^{1,2}, J. F. Chen^{1†}, K. B. Liu²

¹National Cheng Kung University, Tainan, Taiwan

²National Synchrotron Radiation Research Center, Hsinchu, Taiwan

Abstract

A novel high-step-down corrector magnet power supply is designed for use in Taiwan Photon Source (TPS). The TPS booster ring, transfer line, and storage ring correction magnet power supply have more than 950 units, and the power consumption must be examined to improve the corrector power supply's efficiency and voltage gain ratio. This corrector magnet power supply is integrated with an isolated transformer and switched capacitor technology. In this work, the input voltage is 400 V via the proposed converter transfer, with a low output voltage of 48 V being supplied to the bulk power of the corrector magnet. Isolated transformer and switched capacitor technologies are integrated to achieve a high conversion ratio without an extra duty cycle. The output voltage ripple is reduced because the input current is rendered continuous by switch capacitor technology. Isolated transformer technology is applied for the inductor coil turns ratio to obtain high-voltage step-down gain. Additionally, a passive clamp circuit is used for energy recovery by the leakage inductor energy of the coupled inductor. Therefore, converter efficiency can be improved, and high-voltage step-down gain can be obtained. The continuous conduction mode and formula derivation are discussed. A 960 W high-efficiency and high-voltage-gain DC-DC step-down converter is simulated in a laboratory. The simulation results verify the performance of the proposed converter.

INTRONDUCTION

Taiwan Photon Source (TPS) should be installed with 1,032 sets of corrector magnet power supply for booster and storage ring correction magnets. Currently, the correction power supply mainly uses DC-DC converter architecture technology and a phase-shift full-bridge converter with current doubling technology to transfer energy to the magnet. This circuit must adopt multiple switches and generate a high voltage stress caused by high switching losses in the switch. The power loss directly affects the temperature of the main board even when a large heat sink is used in the main switch. A variation in the temperature of the corrector power supplies leads to a jetted long-term beam stability of the light source because the long-term stability of power supplies is a key point in achieving sufficient stability that is required to provide a stable beam in the light

source. Normally, the phase-shift full-bridge technical efficiency of corrector power supplies is less than 95% [1],[2].

The front part of this power supply requires 48 V of bulk voltage. The Taiwan Synchrotron Radiation Research Center spent 100 million US dollars to build solar modules. The solar cells purchased by TYNSOLAR Co., Ltd., are composed of single crystal silicon modules. The maximum power of the TYNS62610290 module is 290 w, the open circuit voltage is 39.54 V, and the 10 modules are connected in series to reach 2.9 kW of maximum power and 395.4 V of maximum input voltage for the bulk converter. In this study, the design of high-step-down circuits was developed within the TYNSOLAR photovoltaic module of the corrector magnet bulk converter. Many previous studies have examined high-step-down converter technologies, such as switched capacitor technology [3],[4], coupled inductor technology [5], and isolated transformer technology [6]. However, high transient current and increased conduction loss in the power switch reduce the converter efficiency in switched capacitor technology. High voltage spike in the power switch reduces converter efficiency when the leakage inductor of the transformer is coupled with inductor technology. Therefore, this work combined an isolated transformer and switched capacitor technology to achieve a high step-down ratio without an extra duty cycle. Section II discusses continuous conduction mode (CCM) operation and presents a steady-state analysis. Section III introduces the result of the simulation software Simplis for the proposed converter. The conclusions are provided in Section IV.

OPERATION PRINCIPLE OF THE PROPOSED CONVERTER

Figure 1 shows the proposed isolated transformer and switch capacitor buck converter. In the red block, it is a conventional step-down circuit with switch capacitor technology, it consists of a capacitor in series with the secondary winding, and two diodes and output capacitors. The isolated transformer technology is shown in the blue block, both coupled winding have turn ratios of is $N_p: N_s = 3:1$. L_m and L_k are the magnetizing and leakage inductors. Passive clamp circuit is shown in the green block, it consists of a clamp capacitor and two diodes, energy of leakage inductor will be recycled to clamp capacitor and voltage stress of main power switch can be reduce.

† Chenjf@mail.ncku.edu.tw

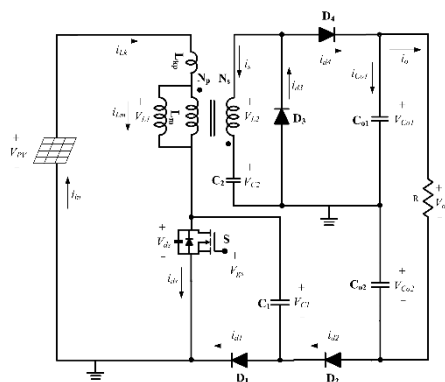

Figure 1: Proposed Converter Equivalent Circuit.

Figure 1 shows the proposed isolated transformer and switch capacitor buck converter. The red block denotes a conventional step-down circuit with switch capacitor technology. It consists of a capacitor in series with the secondary winding and two diodes and output capacitors. Isolated transformer technology is shown in the blue block. The coupled windings have turn ratios of $N_p : N_s = 3 : 1$. L_m and L_k are the magnetizing and leakage inductors. A passive clamp circuit is shown in the green block, and it consists of a clamp capacitor and two diodes. The energy of the leakage inductor is recycled to the clamp capacitor, and the voltage stress of the main power switch can be reduced.

CCM has five operation stages. The control principle for the proposed converter is as follows: the main power switch is turned on in stages I and IV and turned off in stages II–IV. Figures 2(a)–2(e) show the operation stages. Stages II, III, and V present a short switching period and are thus ignored to simplify the steady-state analysis.

Stage I: The main power switch is turned on, and the equivalent circuit is shown in Fig. 2a. The PV high-voltage source and a magnetizing inductor supply energy to switch capacitor C_2 via isolated transformer and diode D_3 . The leakage magnet i_{Lk} and magnetizing inductor current i_{Lm} increase linearly, and the clamp circuit of capacitor C_1 releases energy to low-voltage output capacitor C_{o2} . This stage ends when the power switch is turned off.

Stage II: The main power switch is turned off, and the equivalent circuit is shown in Fig. 2b. The PV high-voltage source and a magnetizing inductor supply energy to switch capacitor C_2 via isolated transformer and diode D_3 and parasitic capacitor C_{ds} of the main power switch S . This stage ends when the parasitic capacitor C_{ds} energy becomes fully charged.

Stage III: The main power switch is turned off, and the equivalent circuit is shown in Fig. 2c. The PV high-voltage source supplies energy to magnetizing inductor, clamp capacitor C_1 , and switch capacitor C_2 via diode D_3 . This stage ends when the voltage of capacitor C_2 is equal to the voltage of output capacitor C_{o1} .

Stage IV: The main power switch is turned off, and the equivalent circuit is shown in Fig. 2d. The PV high-voltage source and magnetizing inductor supply energy to clamp capacitor C_1 via diode D_1 . Secondary winding and capacitor C_2 release energy to output capacitor C_{o1} via diode D_4 . This stage ends when the main power switch is turned on.

Stage V: The main power switch is turned on, and the equivalent circuit is shown in Fig. 2e. The PV high-voltage source, magnetizing inductor, and switch capacitor C_2 release energy to output capacitor C_{o1} via diode D_4 . The clamp circuit of capacitor C_1 releases energy to low-voltage output capacitor C_{o2} . This stage ends when the secondary winding current is released energy to empty.

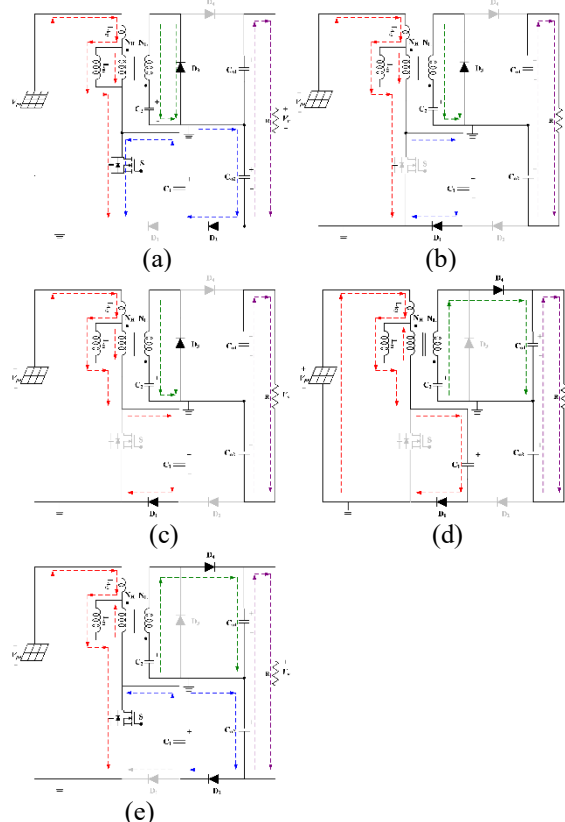

Figure 2: Operating stages (CCM) of proposed converter a Stage I, b Stage II, c Stage III, d Stage IV, e Stage V.

SIMULATION RESULT OF PROPOSED CONVERTER

A 960W proposed converter is simulated, and its specifications are as follows:

- Input DC voltage V_{in} : 400 V;
- Output DC voltage V_o : 48 V;
- Maximum output power: 960 W;
- Switch frequency: 50 kHz;
- Main switch: Ideal;
- Diodes ($D_1 \sim D_4$): Ideal;
- Capacitors: C_1, C_{o2} : 100 μF , C_2 : 20 μF , C_{o1} : 220 μF .
- Transformer: $N_p : N_s = 3 : 1$, $L_m = 33 \mu\text{H}$.

This section shows the simulation experiment on voltage and current waveforms. Figure 3 presents the primary winding leakage magnetizing current, secondary winding

Content from this work may be used under the terms of the CC BY 3.0 licence (© 2018). Any distribution of this work must maintain attribution to the author(s), title of the work, publisher, and DOI.

inductor current, and gate-to-source voltage of the main power switch at full loading. Leakage magnet i_{Lk} and magnetizing inductor current i_{Lm} increase linearly, and the secondary inductor current does not have zero current when the main power switch is turned on. Figure 4 shows all of the diode currents and gate-to-source voltages of the main power switch. The PV high-voltage source and magnetizing inductor supply energy to switch capacitor C_2 via isolated transformer and diode D_3 , and capacitor C_2 charges energy by capacitor C_1 via diode D_2 when the main switch is turned on. Diodes D_1 and D_4 are turned on when the main switch is turned off. Figure 5 shows the current and voltage of output loading. The output current is 20 A, and the output voltage is 48 V.

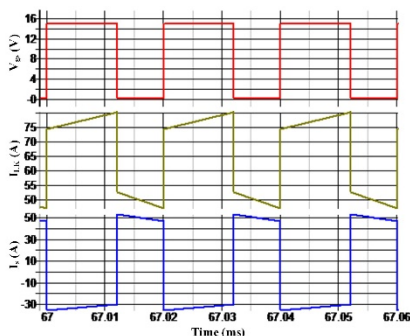

Figure 3: Simulation waveform of v_{gs} , i_{Lk} , and i_s under full-load $P_o = 960$ W.

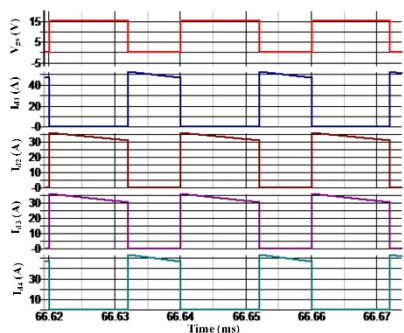

Figure 4: Simulation waveform of v_{gs} , i_{d1} , i_{d2} , i_{d3} and i_{d4} under full-load $P_o = 960$ W.

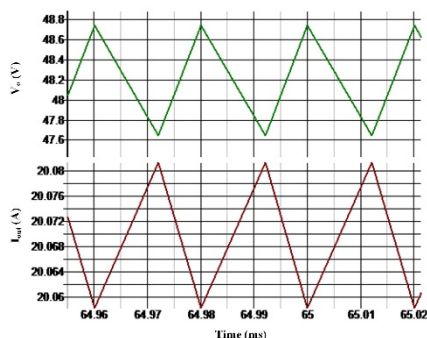

Figure 5: Simulation waveform of v_o , and i_o under full-load $P_o = 960$ W.

CONCLUSION

This study successfully simulated a high-efficiency and high-conversion-ratio isolated DC–DC converter with a switch capacitor and isolated transformer technology. The input source was photovoltaic, and the output loading was corrector magnet bulk power. The input voltage was 400 V and decreased to the output voltage of 48 V, 20 A. The maximum output power was 960 W. This proposed converter uses an isolated transformer and switch capacitor to obtain a high step-down voltage gain. The clamp circuit has a clamp diode, and the clamp capacitor can recover energy by using the leakage inductor. Therefore, the voltage stress on the main power switch can be reduced, and components with low voltage stress were selected. Finally, Simplis simulation software was used to verify the proposed circuit's architecture.

ACKNOWLEDGEMENTS

This work were supported in part by the National Synchrotron Radiation Research Center and National Cheng Kung University. The authors also gratefully acknowledge the helpful comments and suggestions of the colleagues and professor, which have improved the presentation.

REFERENCES

- [1] C.Y. Liu, J. Chiou, Y. C. Chien and C. H. Kuo, "Modification of the correction bipolar power supply of the storage ring," in *Proc. IEEE PAC'03*, pp. 764-766.
- [2] K. B. Liu, Y. D. Li, B. S. Wang and K. T. Hsu, "TPS corrector magnet power converter," in *Proc. IPAC'10*, pp. 3269-3271.
- [3] S. Xiong, S. C. Wong, S. C. Tan and C. K. Tse, "A Family of Exponential step-down switched-capacitor converters and their applications in two-stage converters," *IEEE Transactions on Power Electronics*, vol. 29, no. 4, pp. 1870- 1880, 2014.
- [4] J. Han, A. V. Jouanne and G. C. Temes, "A new approach to reducing output ripple in switched-capacitor-based step-down DC-DC converters" *IEEE Transactions on Power Electronics*, vol. 21, no. 6, pp. 1548- 1555, 2006.
- [5] K. Bhattacharyya and P. Mandal, "Technique for the reduction of output voltage ripple of switched capacitor-based DC-DC converters," *IET Circuits, Devices & Systems*, vol. 5, no. 6, pp. 442-450, 2011.
- [6] A. Ramesh Babu, Raghavendiran, B. P. Gladly and G. T. Sundar Rajan, "Novel non-isolated high step-down three phase interleaved DC-DC converter with capacitor voltage division techniques," in *Proc. IEEE ICCPCT'17*, pp. 1-7