

A TM_{01} MODE LAUNCHER WITH QUADRUPOLE FIELD COMPONENTS CANCELLATION FOR HIGH BRIGHTNESS APPLICATIONS

G. Castorina*, L. Ficcadenti, M. Migliorati, A. Mostacci, L. Palumbo,
University of Rome "La Sapienza", Rome, Italy
F. Cardelli, G. Franzini, A. Marcelli, B. Spataro, INFN-LNF, Frascati (Rome), Italy
G. Sorbello, University of Catania, Catania, Italy
L. Celona, S. Gammino, G. Torrisi, INFN-LNS, Catania, Italy
A. Cahill, J. Rosenzweig, UCLA, Los Angeles, California, USA
V.A. Dolgashev, SLAC, Menlo Park, CA, USA

Abstract

The R&D of high gradient radiofrequency (RF) devices is aimed to develop innovative accelerating structures based on new manufacturing techniques and materials in order to construct devices operating with the highest accelerating gradient. Recent studies have shown a large increase in the maximum sustained RF surface electric fields in copper structures operating at cryogenic temperatures. These novel approaches allow significant performance improvements of RF photoinjectors. Indeed the operation at high surface fields results in considerable increase of electron beam brilliance. This increased brilliance requires high field quality in the RF photoinjector and specifically in its power coupler. In this work we present a novel power coupler for the RF photoinjector. The coupler is a compact X-band TM_{01} mode launcher with a fourfold symmetry which minimized both the dipole and the quadrupole RF components.

INTRODUCTION

Nowadays, the attainment of higher accelerating gradients and the construction of the so called 5th generation light sources, i.e. hard X-ray Free Electron Lasers (FEL), are two of the hot topics in the modern accelerator technology. The first one is mainly limited by the RF breakdown phenomenon occurring in normal conducting metallic structures. Recent research has shown that accelerating gradients up to 250 MV/m are feasible using cryogenically cooled copper accelerating structures [1].

Further development of X-ray FELs requires a substantial RF photoinjectors R&D in order to improve electron beam quality. Main part of the RF photoinjector is the RF gun.

The higher is the electric field on the cathode surface of the gun the lower the beam emittance [2]. Such low emittance could be degraded by the multipole components of the gun electromagnetic fields. Therefore, the next generation of RF guns should operate at high gradient while maintaining multipole free fields.

Among the most promising techniques to reduce the breakdown probability in a RF gun is coupling the power from the axis, actually removing the coupler from the main cell where the probability of the RF breakdown is higher [3].

* giovanni.castorina@uniroma1.it

This coupling layout is possible by going from the rectangular TE_{10} mode to the circular TM_{01} mode. This conversion is possible introducing a microwave device called TM_{01} mode launcher [4].

Since this layout is extremely promising, in this contribution we will discuss an improved TM_{01} mode launcher. This modified version, based on a four fold symmetry, allows the on-axis power coupling and removing at the same time dipole and quadrupole components. This original and compact layout keeps the maximum surface electric and magnetic fields sufficiently low to guarantee multi-MW delivery (up to 200 MW) to a device of this structure.

GEOMETRY OF THE FOUR-FOLD SYMMETRY MODE LAUNCHER

A X-band mode launcher with four-fold symmetry has been designed, see Fig. 1. The launcher consists of two standard WR90 waveguides with $a = 22.86$ mm and $b = 10.16$ mm and of a circular waveguide with radius $r_W = 11.43$ mm. The cut-off frequencies of this waveguide are 7.68, 10 and 12.7 GHz, respectively for the TE_{11} , TM_{01} and TE_{21} mode. The rectangular waveguides are crossed at 90 degree. The circular waveguide, which will be directly connected to the RF gun, is placed at the intersection point of the rectangular ones. The symmetry described allows us to simulate only one eighth of the device. Finally a pair of inductive matching protrusions (bumps) are included for the tuning of the device. Sharp edges, in the whole design and in particular on matching bumps, were avoided to reduce electrical and magnetic field enhancements and thus minimizing breakdown probability. A circular curvature with radius between 5 and 8 mm has been employed.

The reflected power at the rectangular port is minimized by varying the position z_B of the bumps axis and w_B dimension. The total length of the bumps h_B is maintained constant and the optimized dimensions are $z_B = 4.858$ mm, $w_B = 5.181$ mm and $h_B = 12$ mm. To allow the beam to go through the circular waveguide a beam pipe with a radius of 6.35 mm (TE_{11} cut-off frequency of 13.8 GHz) has been included. For the design we used the commercial code ANSYS HFSS [5].

In a real scenario the mode launcher should be fed by a dedicated matched 4-harm power delivery network discussed in the next section.

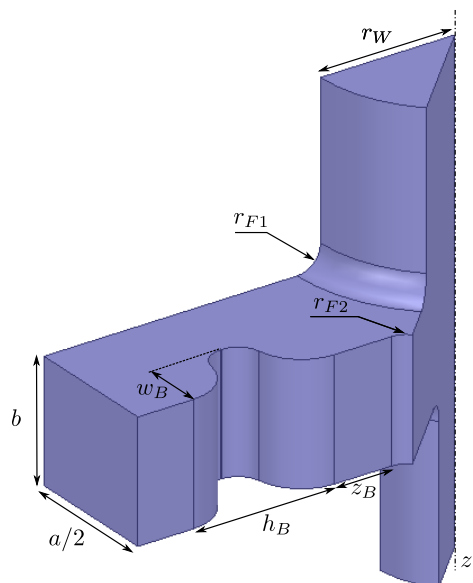

Figure 1: Geometry of the four folded TM_{01} mode launcher. Due to the symmetry planes only one eighth of the device is used for the simulation. The dot dashed line is the symmetry axis and the propagation trajectory of the electron bunch.

POWER DELIVERY NETWORK

The TM_{01} mode launcher can be fed by a standard branched power network with three 3-dB power splitters and symmetric waveguide lines. However, this standard branched network is cumbersome. As a consequence we considered a more compact design shown in Fig. 2. The new feeding layout employs only one symmetric 3-dB splitter and is confined in two-dimensions in the H-plane.

The network is composed by two symmetric arms and one input waveguide. In the middle of each arm an asymmetric 3-dB power splitter is inserted to feed the ports labeled as 2 and 4, which are the nearest to the input port. The other output ports (#3 and #5) are the endpoints of the symmetric arms. The power flows through the port 1, which is directly connected to the klystron.

Thanks to this power distribution scheme, the power level at the output ports is equal and the four input ports of the mode launcher can be excited with the same field amplitude. The power difference between adjacent ports is 0.02 dB.

To properly feed the TM_{01} mode launcher both amplitude and phase of the field has to be the same. In a standard tree design, the same phase at the output ports is guaranteed by the symmetry of the power delivery feeding network employing 3-dB splitters. However, in the present asymmetric design a tuning delay line must be introduced. The bending arm between ports #2 and #3 can be tuned as a delay line to match the phase at the output ports. Other solutions for phase matching could be used: modulation of the propagation constant or different straight waveguide width. Our solution is simple and keeps the device compact. The mode launcher and the entire feeding network can be enclosed in a box with a transverse dimension of $0.25 \times 0.25 \text{ m}^2$ for a

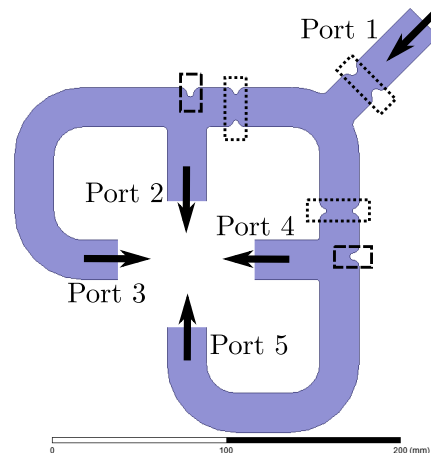

Figure 2: Geometry of the feeding network. The mode launcher is set in the center of the power delivery network.

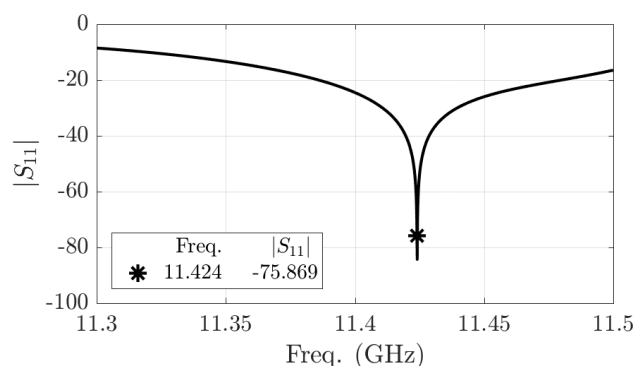

Figure 3: Reflection vs. frequency for the full device shown in Fig. 4. At the working frequency of 11.4240 GHz, $|S_{11}|$ is below -75 dB, and the bandwidth at -20 dB is 90 MHz.

typical X-band device. The phase difference between any pair of ports is equal to 0.08 deg. The bottleneck of this configuration, as compared to the standard tree design, is the large sensitivity to frequency variations. However, this issue is not relevant for the present application where the frequency must be defined with a great accuracy.

The design is completed with three pairs of matching bumps to minimize the reflected power. It is necessary to add a couple of bumps before each splitter to avoid standing wave patterns in the bent radii, see the dashed box in Fig. 2. Indeed, if only two matching bumps are added to the design, the reflected power can be minimized but a standing wave can be trapped inside the bends and could be source for multipacting. The whole system (power delivery network and mode launcher) has been simulated and the $|S_{11}|$ is plotted in Fig. 3. A mechanical tolerance of $0.5 \mu\text{m}$ has been considered during the design optimization.

The surface electric and magnetic peak fields are sufficiently low for a high gradient operation when an input power of 200 MW is used. With such power, the peak surface electric field is 75 MV/m while the magnetic field is 25 kA/m, see Fig. 4 [6].

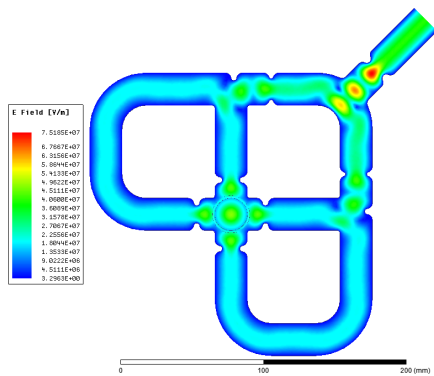

Figure 4: Plot of the electric field for the proposed design. The maximum is located in the first splitter region.

HARMONIC ANALYSIS OF THE FIELDS

In order to quantify the minimization of the quadrupole component, a Fourier analysis of the field has been conducted. The integrated voltage has been calculated for both co-propagating and counter-propagating particles:

$$V_{\mp}(r, \theta) = \int_{z_0}^{z_f} E_z(r, \theta, z) e^{\mp i k_0 z} dz, \quad (1)$$

where r is the radius, θ the azimuthal coordinate, k_0 the wavenumber of the RF input power and z_0, z_f the limits of integration on longitudinal axis. Therefore the discrete Fourier transform has been calculated as in [7] [8]. The coefficients have been calculated for the proposed design and for a dipole compensated one with only two feeding ports (here not shown for sake of brevity).

In both cases, co- and counter-propagating particles, the quadrupole coefficients, $M_{\mp 2}$, are reduced at least of one order of magnitude. A decrease of the dipole components, $M_{\mp 1}$, is also obtained. Higher modes coefficients, $M_{\mp 4}$ and $M_{\mp 8}$, are increased but their effect on beam dynamics is negligible.

The designs proposed here can also be used for a high over-coupled gun, because the cancellation of the quadrupole fields acts on both co- and counter-propagating fields.

CONCLUSION

A novel RF power coupler for RF photoinjector designed for high brightness applications has been presented. It is a X-band TM_{01} waveguide mode launcher which minimizes dipole and quadrupole field components. Minimization of multipole field components was achieved by using a power delivery network with four symmetric waveguide ports.

For transmitted RF power of 200 MW, the surface peak electric field is 75 MV/m and the magnetic field is 25 kA/m which corresponds to a temperature increase of 3 °C for a 5- μ s pulse. At this high power the fields and the peak pulse surface heating are well within the safe operating limits.

The minimization of the quadrupole component has been quantitatively estimated by analysis of the discrete Fourier

Table 1: Discrete Fourier Coefficients for Counter-Propagating Particles (results have been multiplied by 10^3)

	$M_{-,1}$	$M_{-,2}$	$M_{-,4}$	$M_{-,8}$
Two ports device	1.64	2.77	1.02	2.15
Four ports device	0.26	0.09	3.29	0.12

Table 2: Discrete Fourier Coefficients for Co-Propagating Particles (results have been multiplied by 10^3)

	$M_{+,1}$	$M_{+,2}$	$M_{+,4}$	$M_{+,8}$
Two ports device	2.27	2.91	3.60	1.39
Four ports device	1.04	0.25	9.36	2.96

coefficients. At least a reduction of one order of magnitude has been obtained for the considered cases.

A prototype of the device is under realization at LNS-INFN. The measurements and the comparison with simulations will be object of a successive dedicated paper.

REFERENCES

- [1] A. Cahill *et al.*, "Ultra-high gradient breakdown rates in X-band cryogenic normal-conducting Rf accelerating cavities." 8th Int. Particle Accelerator Conf. (IPAC'17), Copenhagen, Denmark, 14-19 May, 2017. JACOW, Geneva, Switzerland, 2017.
- [2] J. Rosenzweig *et al.*, "Ultra-high brightness electron beams from very-high field cryogenic radiofrequency photocathode sources." Nuclear Instruments and Methods in Physics Research Section A: Accelerators, Spectrometers, Detectors and Associated Equipment, arXiv:1801.06765 (2018).
- [3] V. Dolgashev and S. Tantawi, "Effect of RF parameters on breakdown limits in high-vacuum X-band structures." AIP Conference Proceedings. Vol. 691. No. 1. AIP, 2003.
- [4] C. Nantista, S. Tantawi, and V. Dolgashev, "Low-field accelerator structure couplers and design techniques." Physical Review Special Topics-Accelerators and Beams 7.7 (2004): 072001.
- [5] <http://www.ansys.com/>
- [6] Demetra Activity Report INFN-LNF (2016), private communication.
- [7] A. Cahill, V. Dolgashev, and M. Dal Forno., "TM01 mode launcher for use in high brightness photoguns." (2016): MOPMW039.
- [8] G. Castorina *et al.*, "A novel highly symmetric TM mode launcher for ultimate brightness applications", INFN - 18-01/LNF (2018).