

Content from this work may be used under the terms of the CC BY 3.0 licence (© 2017). Any distribution of this work must maintain attribution to the author(s), title of the work, publisher, and DOI.

UPGRADE OF VACUUM CONTROL SYSTEM FOR KOMAC LINAC AND BEAMLINES

Jae-Ha Kim[†], YoungGi Song, Dae-il Kim, Sang-Pil Yun, Seok-geun Lee, Hyeok-Jung Kwon, Yong-Sub Cho, Korea Multi-purpose Accelerator Complex, Korea Atomic Energy Research Institute, Gyeongju, Korea

Abstract

At Korea Multi-purpose Accelerator Complex (KOMAC), we have been operating a proton linac since 2013 [1]. It consists of a 100 MeV accelerator and 5 operational target rooms. Beam operation at KOMAC is carried out by a home-grown control system with a machine protection system which affects the accelerator the least when the machine suddenly fails. Our work is mainly concentrated on interlock sequence of vacuum related equipments based on a programmable logic controller (PLC). PLCs monitor vacuum status and control vacuum pumps and gate valves. By applying interlock sequence to PLCs connected to the vacuum equipments, we close gate valves to isolate a failed part so the the rest of the accelerator remains under vacuum, and safely shut down the vacuum pumps. Then the MPS receives a signal to safely stop the beam operation to protect the accelerator. We describe in this paper architecture of our PLC on interlock sequence of vacuum related equipment and its implementation.

INTRODUCTION

A 100 MeV accelerator comprises of an ion source, a radio-frequency quadrupole (RFQ) and 11 drift tube linacs (DTLs). We have beam lines to transport proton beam from the accelerator to 5 target rooms. The entire accelerator and beam lines are under vacuum and it is important to keep a certain appropriate vacuum level for a reliable beam operation. For this, we chose Programmable Logic Controllers (PLCs) and EPICS Input and Output Controller (IOC) for reliability of the vacuum system [2].

As we have been constructing additional beam lines and target rooms to..., correspondingly increasing vacuum system and related control system need to be installed, and to be linked.... We have designed an architecture for the required vacuum control system and implemented it for all the beam lines and operational target rooms. In this paper, we present upgradation of our vacuum control system for a safe operation of our 100 MeV proton accelerator at KOMAC.

VACUUM CONTROL SYSTEM

KOMAC Control System

KOMAC has developed EPICS based control system for a 100 MeV proton linac. The control system is largely divided into three types: DLINAC Control system to control and to monitor linac state; Timing system for synchro-

nizing all devices; and Data Management system for archiving and analysing acquired data. Following Figure 1 shows the block diagram of KOMAC control system.

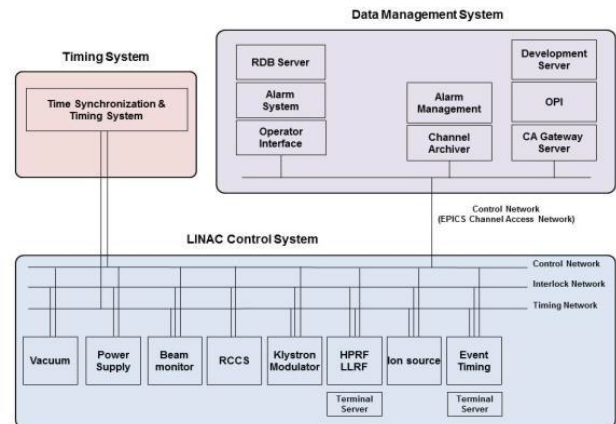

Figure 1: Block diagram of KOMAC control system.

Vacuum System

The vacuum system comprises scroll pumps, turbo-molecular pumps, ion pumps, gate valves and vacuum gauges. Figure 2 shows the vacuum system for a KOMAC 100 MeV linac.

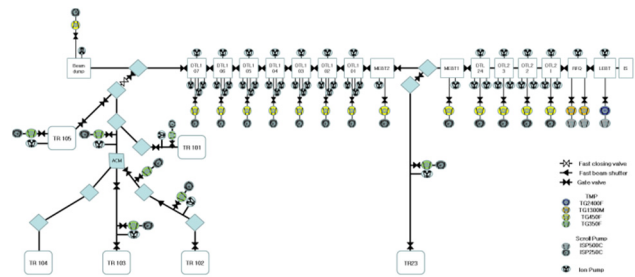

Figure 2: Block diagram of KOMAC vacuum system.

PLCs and Controllers for control those components are installed on the second floor named Klystron gallery. Allen-Bradely ContorLogix PLC is adopted for KOMAC vacuum system. PLCs control and monitor scroll pumps and gate valves. There are two EPICS IOC for vacuum control system; an EPICS IOC for controlling or monitoring PLC using EPICS Ether/IP modules the other EPICS IOC for vacuum gauge controllers and TMP controllers using EPICS ASYN module and STREAM module. Sequencer driver is used to prevent entering undesired state and send interlock signals and alarm to other subsystems via Channel Access (CA) protocol.

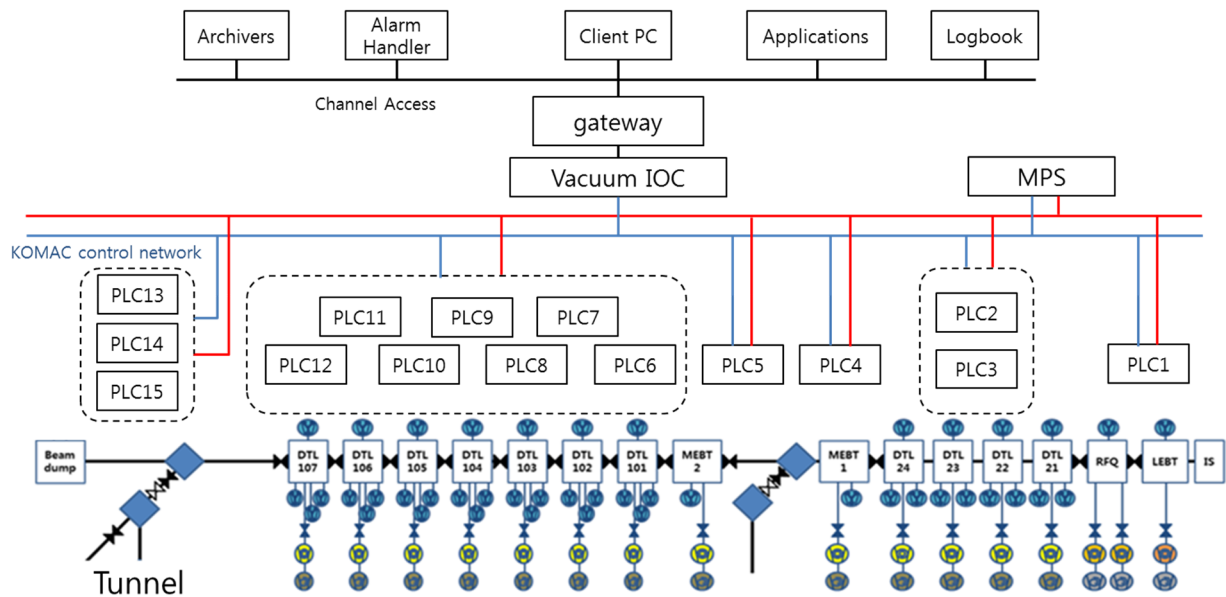

Figure 3: The architecture of vacuum system.

To provide beam users with various experimental environments, we have constructed additional beam lines. Then additional vacuum control systems for beam lines also need to be implemented. So the typical and upgraded vacuum control system is established. The architecture of vacuum system is shown Figure 3.

Low-energy components, including an ion source, a Low-Energy Beam Transport (LEBT), a RFQ, a 20 MeV Drift Tube Linac (DTL) and MEBT are controlled by five PLCs. High-energy components and beam lines are managed by 10 PLCs. The vacuum devices such as pumps and valves for each sector are controlled by each PLC. Following Figure 4 shows hardware layout of vacuum control system.

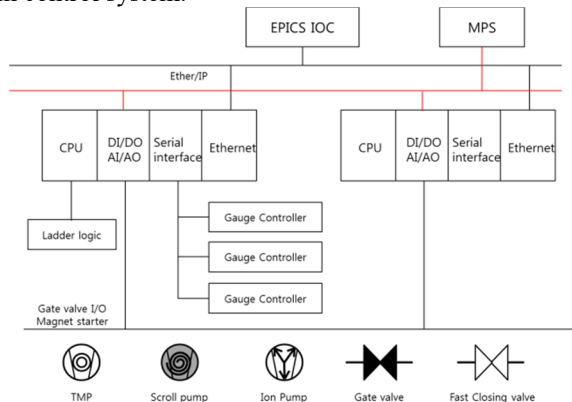

Figure 4: Block diagram of KOMAC vacuum control system.

One IOC is used control all the PLCs for Low-energy parts and High-Energy parts. We also have integrated the two EPICS IOCs into one by controlling gauge controllers and TMP controllers using PLCs and have made connection between PLC and Machine Protection System with di-

rect cable. We added an interlock sequence to the PLC control logic to close gate valve. The interlock sequence will be run in undesired stat as shown in Table 1.

Table 1: The Vacuum Monitoring Parameter and Interlock

	Monitoring	Interlock
Gate valve	GV state	RF / Beam OFF
Scroll pump	Pump state	RF / Beam OFF GV/ close
TMP	TMP state	RF / Beam OFF GV Close
FCV	FCV state	Beam OFF
Safety Block	SB state	Beam OFF
Pressure	Vacuum Pressure	RF / Beam OFF G/V Close

The detection of exceeding a specified limit will close the gate valve to prevent propagation of leaks and provide interlock signals to Machine Protection System and other system through hardware and software. Then IOC for PLCs sends interlock outputs to the preceding PLC and the following PLC to close gate valve.

Vacuum Control

We also have upgraded the vacuum control interface to provide convenience to operators and users. Touch screens for local control and enable or disable interlock are installed. Following Figure 5 shows touch panel for local vacuum control.

Vacuum control interface are designed using Control Studio System, accessing IOC via Channel Access protocol. The Operating Interface divided into 2 parts, monitoring Interface and control Interface. Figures 6 and 7 show interfaces for the vacuum control system.

Content from this work may be used under the terms of the CC BY 3.0 licence (© 2017). Any distribution of this work must maintain attribution to the author(s), title of the work, publisher, and DOI.

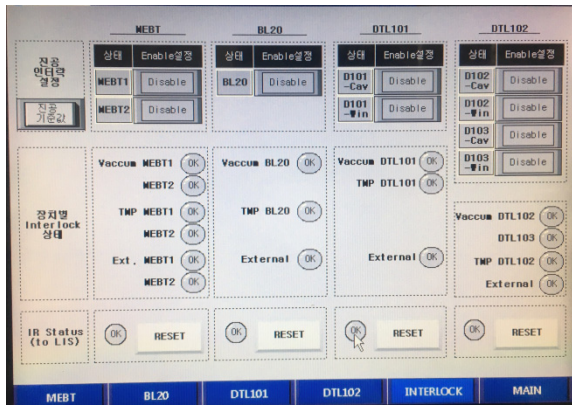

Figure 5: Panel for local vacuum control.

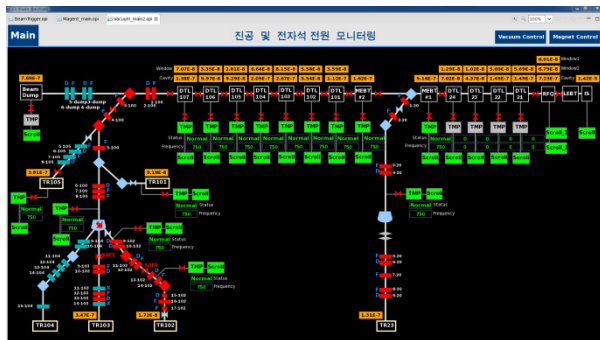

Figure 6: Vacuum control interface 1.

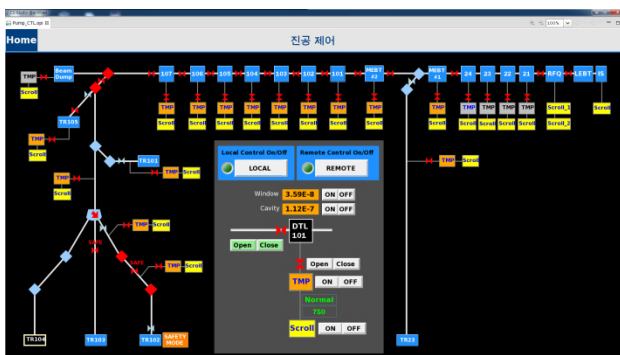

Figure 7: Vacuum control interface 2.

The OPI for monitoring vacuum system displays state of vacuum instruments and degree of vacuum in torr and alarm state. Each PLC for vacuum system has own vacuum control interface. Each PLC control interface is shown by click the sector. The Machine Protection System receives interlock signals from the vacuum control system.

CONCLUSION

The upgraded vacuum control system based on PLC and EPICS IOC has been developed. The focus of upgrade for vacuum system is to prevent leaks from spreading into large volume and to give signals to Machine protection system to shut off the beam. The system was successfully applied a 100 MeV proton linac and the constructed beam lines.

ACKNOWLEDGEMENT

This work has been supported through KOMAC (Korea Multi-purpose Accelerator Complex).

Operation fund of KAERI by MSIT (Ministry of Science and ICT).

REFERENCES

- [1] Yong-Sub Cho, Hyeok-Jung Kwon, Dae-Il Kim, Han-Sung Kim, Jin-Yeong Ryu, Bum-Sik Park, Kyung-Tae Seol, Young-Gi Song, Sang-Pil Yun, and Ji-Ho Jang, "The KOMAC accelerator facility", in *Proc. Int. Particle Accelerator Conf. (IPAC'13)*, Shanghai, China, 2013, pp. 2052-2054.
- [2] Experimental Physics and Industrial Control System (EPICS), <http://www.aps.anl.gov/epics>.