

HELIUM CRYOPLANT OFF-LINE COMMISSIONING AND OPERATOR TRAINING: TWO APPLICATIONS OF THE PROCOS SIMULATION SYSTEM AT CERN

Marco Pezzetti, Benjamin Bradu, Philippe Gayet, Julien Vasseur,
CERN, Geneva, Switzerland.

Abstract

The off-line commissioning step, through reliable simulation of physical models, aims to correct and validate control systems before their implementation into real equipments. It prepares and minimizes plant commissioning phase and at the same time validates the efficiency of the new process control logic. This paper describes how different CERN/UNICOS cryogenic control systems have been pre-commissioned off-line, using the CERN cryogenic simulation environment PROCOS. Some examples are reported. Additionally the presented simulation environment will be used for operator training. The second part of the paper will presents the simulation platform and the first feedback from the operation crew.

INTRODUCTION

The CERN helium cryo-plants [1] are controlled by several industrial Programmable Logic Controllers (PLCs) in order to ensure a high degree of reliability as required by cryogenic operation specification. Moreover, LHC cryogenic control architecture and control policy are based on a hierarchical multilevel and multilayer control framework called UNICOS [2] developed at CERN.

CERN, during the last few years, has shown increasing interest on the real-time simulator techniques dedicated to large cryogenics processes. A Process and Control Simulator (PROCOS) [3] has been developed using a set of nonlinear differential-algebraic-equations to reproduce an adequate behavior during transients and cooldown scenarios.

The resulting simulators have contributed to improve knowledge of cryogenic system [4] but also they have been adapted in order to contribute for a new commissioning technique for helium cryoplant. The virtual commissioning approached [5] has brought an important time saving factor during plant re-start by minimizing unexpected errors in the program producing undesired process behavior.

CONTROL SYSTEM ARCHITECTURE FOR SIMULATION

UNICOS standard uses typical three-layer control architecture (field, control and supervision layers) and the same architecture is used in simulation using PROCOS, see Fig. 1 where the PROCOS architecture is described. The PLCs are replaced by PLC simulators which are software provided by PLC manufacturers and the supervision system (SCADA) remains the same. All

variables are exchanged through an OPC server also provided by PLC manufacturers.

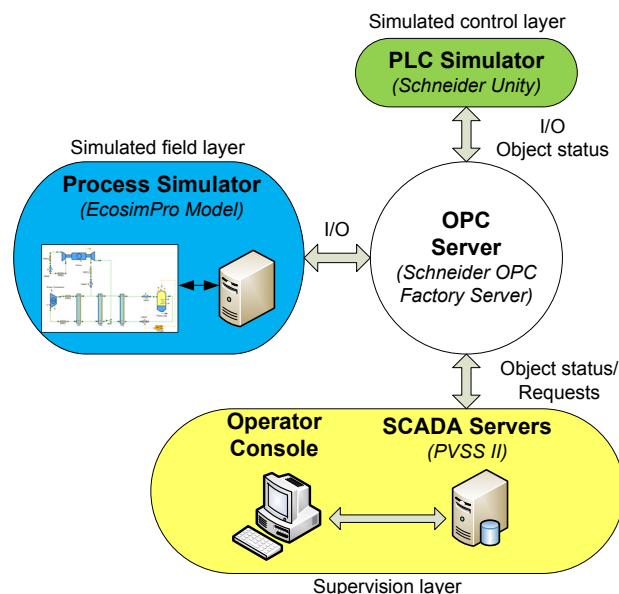

Figure 1 : The PROCOS structure.

Nevertheless, the fact to reuse this architecture implies several constraints for the good working of the virtual commissioning and for operator training. First, real systems are using field buses to exchange data whereas the simulator uses OPC protocol. Thus, all variables have to be mapped differently inside PLCs and SCADA. Fortunately, UNICOS is based on code generators (for PLC and SCADA) allowing us to generate automatically all modifications in an efficient and fast way.

Moreover, about the half of the sensor signals are not simulated in such cryogenic systems because infrastructure facilities are not embedded in models (power switches, cooling water, compress air and vacuum). Hence, sensor signals which are simulated have to be selected one by one as first step in order to link correctly PLC and model variables through the OPC server and non-simulated sensors have to be forced to correct values in PLCs to ensure the absence of interlocks. Once again, this step is simplified by using automatic generation tools: only modifications in the inputs/outputs database are necessary in this case.

We also have to point out the fact that the achievement of the process model is a difficult task that demands an important development time event if we are now able to construct such a model for a classical system in several

weeks due to our experience on these processes. One of our objectives for the future is to alleviate this step by introducing simplified process dynamics and better generation tools. Figures 2 and 3 show an example of the EcosimPro model with the corresponding synoptic in the SCADA system.

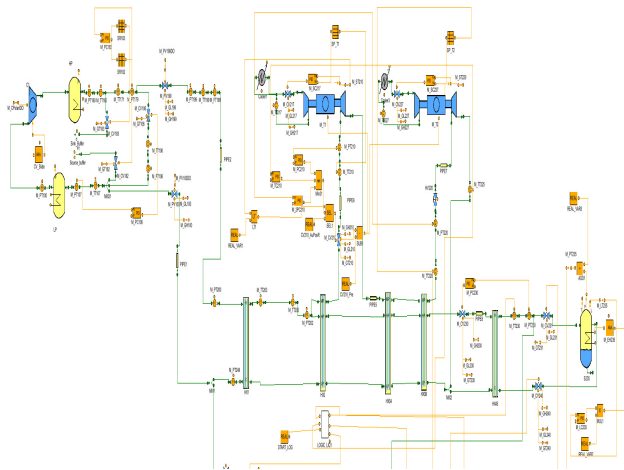

Figure 2: The FRESKA helium refrigerator model.

VIRTUAL COMMISSIONING EXPERIENCE

The virtual commissioning includes operational tests aiming at demonstrating all functions specified in the control system. Once commissioned and qualified for operation, sub-systems are used in a cascade way to commission subsequent sub-systems, progressively allowing testing and tuning collective behavior. This gives the possibility to progressively get experience and define eventual programming errors or adapt corresponding sequences.

Helium Compressor Set

The initial test started from the helium compressor station which provides helium flow to the cold box. Hence the compressor start-up sequence and the high and low pressure control have been verified and adjusted. This step allows us to detect wrong variable connections and wrong ranges of some sensors. Moreover some step conditions were also modified in agreement with our requirements.

Refrigerator Helium Flow Circuit & Turbines Circuit

Once the refrigerator is receiving the helium flow from the compressor it is divided in two streams: the Joule-Thomson circuit (J-T circuit) that goes to the heat exchangers and the phase separator; and the turbine circuit. Each circuit is controlled by a specific process control object managing different actuators. The control logic of the bypass valve in the J-T circuit has been tested with different configurations and the best solution has

Industrial System in Exp./Acc. Physics controls

been chosen in order to achieve a better cool down speed of the system. Moreover the inlet and return valves of the phase separator have been adjusted in order to avoid, in a start up situation, abnormal oscillations caused by the warm helium contained in a close circuit between the client dewar and the cold box.

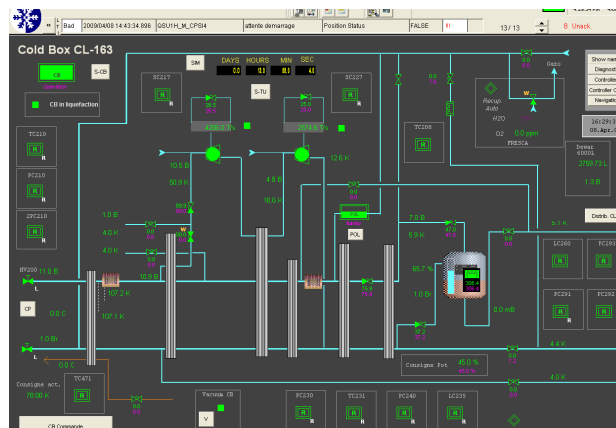

Figure 3: Refrigerator synoptic under PVSS-ETM®.

To enhance turbine safety and stability, a new logic has been developed and validated. The control of the inlet and brake valves were modified according to the new refrigerators technology (Linde®) where the turbine speed is only regulated by the brake valve and the inlet valve regulates the pressures and the outlet temperature. In this work the review of valve ramp slopes, and turbine security interlocks as well as of the PID parameters of the different controllers has been optimised.

OPERATORS TRAINING

Familiarity within the UNICOS Control Framework

The UNICOS framework HMI interacts with operators by mean of widgets and dedicated panels called faceplates. These graphical elements inform operators on the object status and provide dynamic trends, multi-trends, navigation functionalities, interlock diagnostics and allow him to send orders. These facilities make this framework a powerful standardized interface allowing troubleshooting flexibility during tests, and easiness of operation. The virtual operator training finds his best utilities when new technical personnel join the operation team and needs an appropriate and intensive training period for a global discovery of the operation tool.

Training in the Critical Cryogenic Scenarios

PROCOS embeds different useful features for operator training such as the possibility to perform real-time or accelerated simulations and to run, freeze, save and restore predefined process states.

It can also introduce malfunctions in order to trail the operator skills. For example, critical interlocks can be

generated such as a turbine failure in order to evaluate operator reactions.

Finally the PVSS supervision interface also lets the monitoring of the training session progress with trends of process sensors and allows the evaluation of how an identical critical scenario has been dealt under different operation constraints.

CONCLUSION & PERSPECTIVE

The work herein presented has two main contributions: an optimized procedure for virtual commissioning of large-scale cryogenic processes and a starting project for setting up an operator training station.

CERN experience has shown that a control system which has been virtually commissioned with the PROCOS environment shows a high efficiency in the global context and needs only insignificant logic modifications during the real commissioning.

It will be useful to improve software tools in order to render the modeling step easier and faster. Off line commissioning is used only when the time constraint for a complete refurbishing of the control system is the critical factor.

The first results show that the virtual cryogenic operator training is an efficient and pedagogic tool. It allows operators to be trained on the most critical phases of real cryogenic processes. It can also serve as an efficient HMI UNICOS framework guide allowing cryogenic operators to become familiar within a short training period.

ACKNOWLEDGMENTS

The authors would like thank Hervé Coppier from ESIEE-Amiens (France) and Alexandre Moraux from CERN for their contribution and support in this project.

REFERENCES

- [1] Passardi G. and Tavian L., "Cryogenics at CERN", Proceedings of the 19th International Cryogenic Engineering Conference, Grenoble, France, 2002.
- [2] Gayet P. and Barillère R., "Unicos: a framework to build industry-like control systems, principles and methodology", ICALEPCS'05, Geneva, Switzerland, 2005.
- [3] Bradu B., Gayet P. and Niculescu S.I., "A process and control simulator for large scale cryogenic plants", Control Engineering Practice, In Press, (2009).
- [4] Bradu B., Gayet P. and Niculescu S.I. "Dynamic simulation of a 1.8K refrigeration unit for the LHC", Proceedings of the 22nd International Cryogenic Engineering Conference, Seoul, Korea, 2008.
- [5] Rogez E., Bradu B., Moraux A., Pezzetti M., Gayet P. and Coppier H., "A simulation case study for the virtual commissioning of the CERN central helium liquefier", Proceedings of the 22nd International

Cryogenic Engineering Conference, Seoul, Korea, 2008.

- [6] Krause H. "Virtual commissioning of a large LNG plant with the DCS" 6th EUROSIM Congress on Modeling and Simulation, Ljubljana, Slovenia, 2007.