

Requirements and status of PETRA IV Fast Orbit Feedback System



Sajjad Hussain Mirza*, A. Alov, H. T. Duhme, B. Dursun, A. Eichler, S. Jablonski, J. Klute, F. Ludwig, S. Pfeiffer, H. Schlarb, B. Szczepanski, Deutsches Elektronen-Synchrotron DESY, Germany
G. Rehm, Helmholtz-Zentrum Berlin für Materialien und Energie/BESSYII, Berlin, Germany

Abstract

PETRA IV is the upcoming low-emittance, 6 GeV fourth-generation light source at DESY Hamburg. It is based upon a six-bend achromat lattice with additional beamlines as compared to PETRA III. A stringent stability of the electron beam orbit in the ring will be required to achieve a diffraction-limited photon beam quality. In this regard, the requirements and the proposed topology of the global orbit feedback system are discussed for expected perturbations. An initial analysis based upon system requirements, design and modeling of the subsystems of the orbit feedback system is also presented.

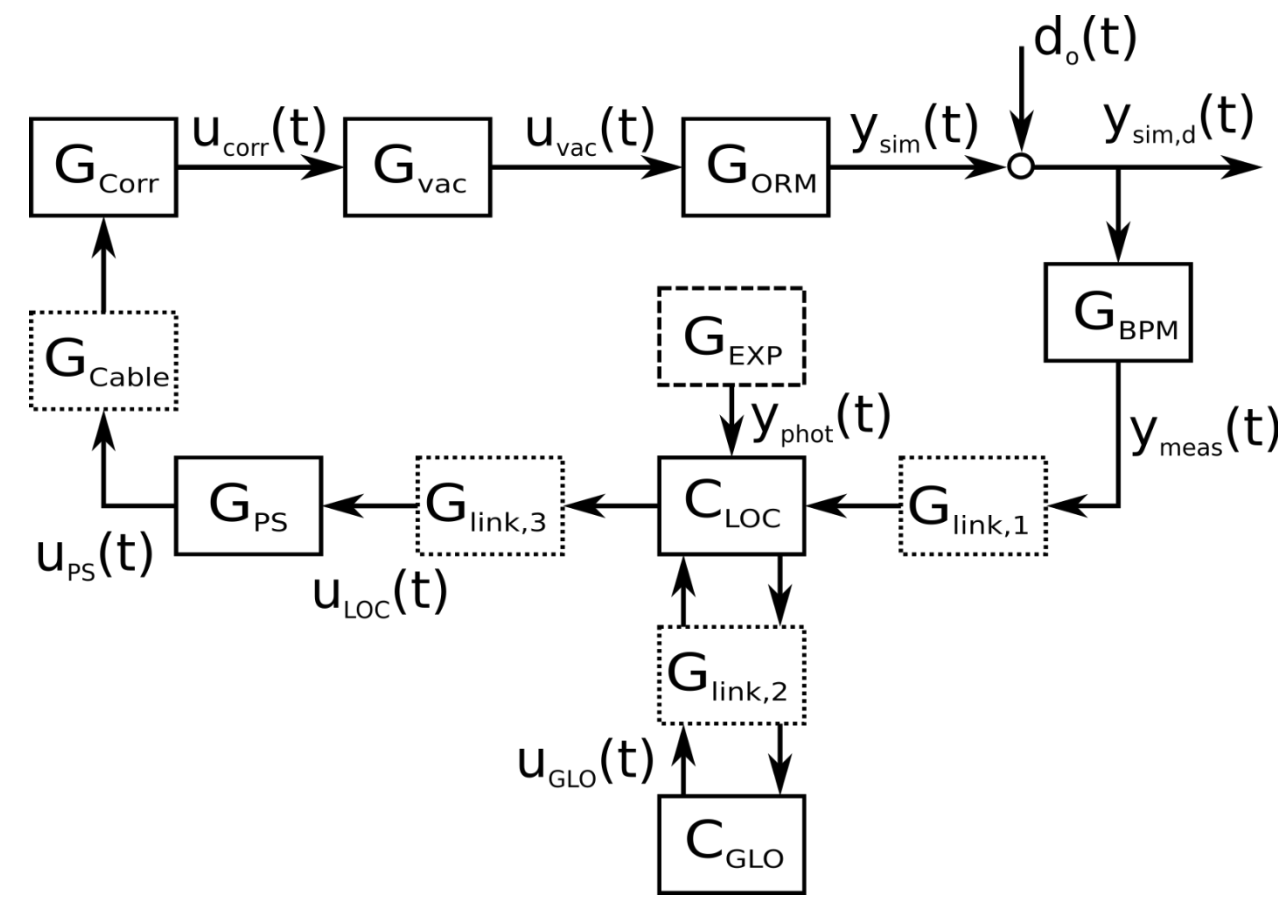

Closed-loop schematic of the FOFB system identifying the individual subsystems

PETRA IV Ring of DESY

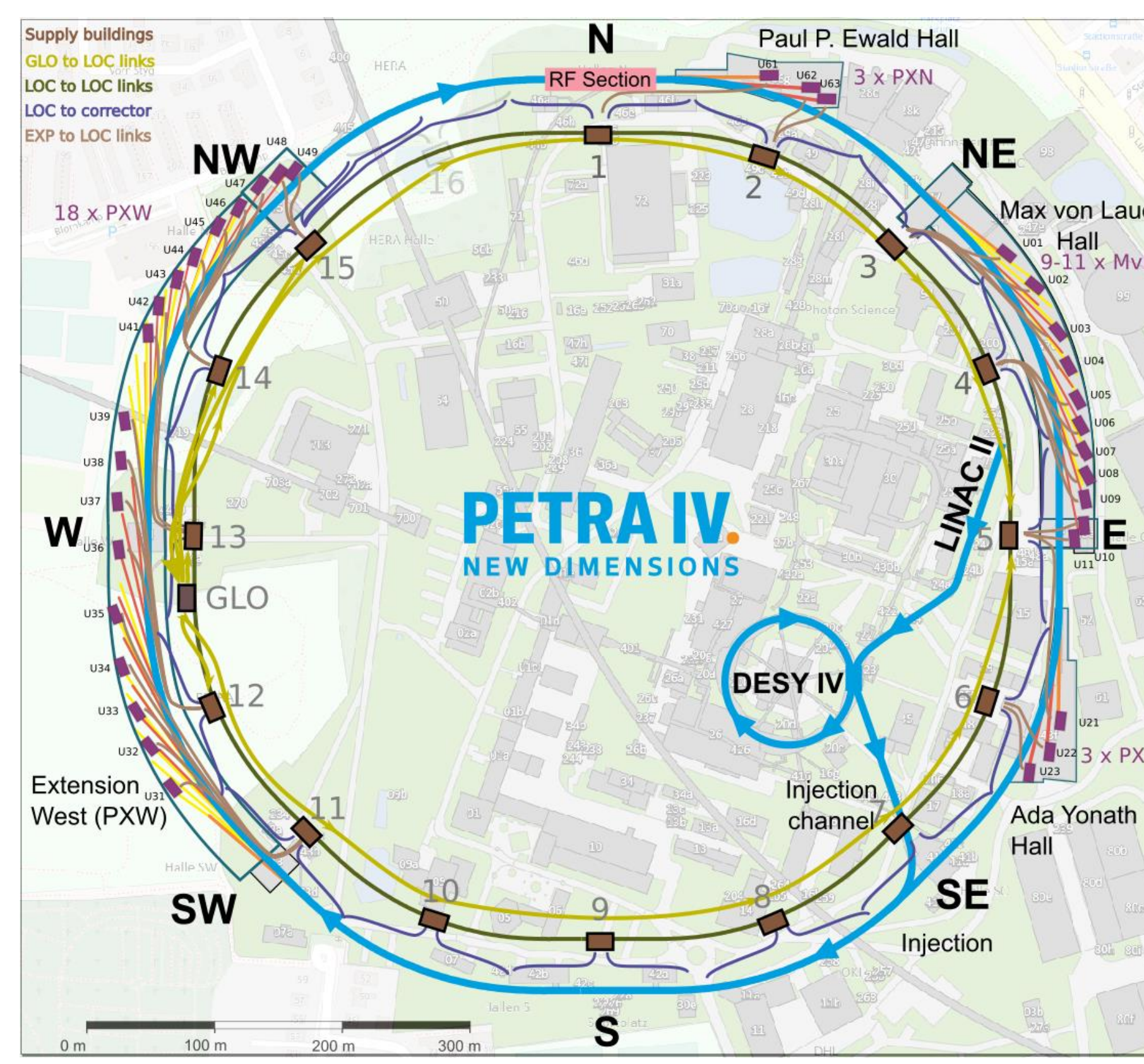

Supply buildings across the ring to serve as local stations for BPM and corrector data collection and distribution.

Requirements

- Aiming for 1 kHz disturbance-rejection bandwidth
- RMS position and pointing angle stability to be 5-10% of beam size and divergence

Electron beam parameters at IDs

Parameter	Value
$\beta_{x,y}$ (standard cell)	2.2, 2.2 (m)
$\beta_{x,y}$ (flagship IDs)	4, 4 (m)
Nat. emittance $\epsilon_{x,y}$	20, 4 (pm rad)
Beam size $\sigma_{x,y}$, standard cell	6.6, 2.97 (μm)
Beam divergence $\sigma'_{x,y}$, standard cell	3.02, 1.34 (μrad)
Beam size $\sigma_{x,y}$, flagship IDs	8.9, 3.98 (μm)
Beam divergence $\sigma'_{x,y}$, flagship IDs	2.23, 1.0 (μrad)

Electron beam stability requirements based upon 10% criteria

Plane	RMS motion
Horizontal at standard cell IDs	660 (nm), 302 (nrad)
Vertical at standard cell IDs	297 (nm), 134 (nrad)
Horizontal at flagship IDs	890 (nm), 223 (nrad)
Vertical at flagship IDs	398 (nm), 100 (nrad)

Proposed topology

- Orbit correction for the full range of disturbance spectrum i.e. from quasi-DC to high frequency (1 kHz).
- 789 beam position monitors (BPMs) and 322 vertical and 200 horizontal fast correctors.
- Extended star topology (latency optimized) having 15 local nodes (LOC) and 1 global central node marked as GLO.
- BPM crates and power supply (PS) racks to be the peripheral nodes for each local star.
- BPM crates in the MicroTCA.4 form factor, housing multiple BPM processors coupled with a data aggregation AMC for transferring the corresponding BPM data to LOC.
- PS units to be distributed into racks with a single optical link per rack.
- The GLO and LOC to have similar hardware of MicroTCA.4 form factor.
- GLO will have bidirectional optical links up to 1.2 km long with all 15 LOCs. Each LOC will have optical links with the local BPM crates and local PS racks.
- Optical links to both neighboring LOCs (upstream and downstream) and experimental stations.
- Data propagation within the MicroTCA.4 backplanes is latency-optimized of the order of 270 ns, while the optical cable paths are bandwidth optimized.
- Data transfer times are up to 6 μs for the longest communication path between LOC and GLO, and expected latency of less than one microsecond for each local communication, i.e. LOC to PS and BPM.

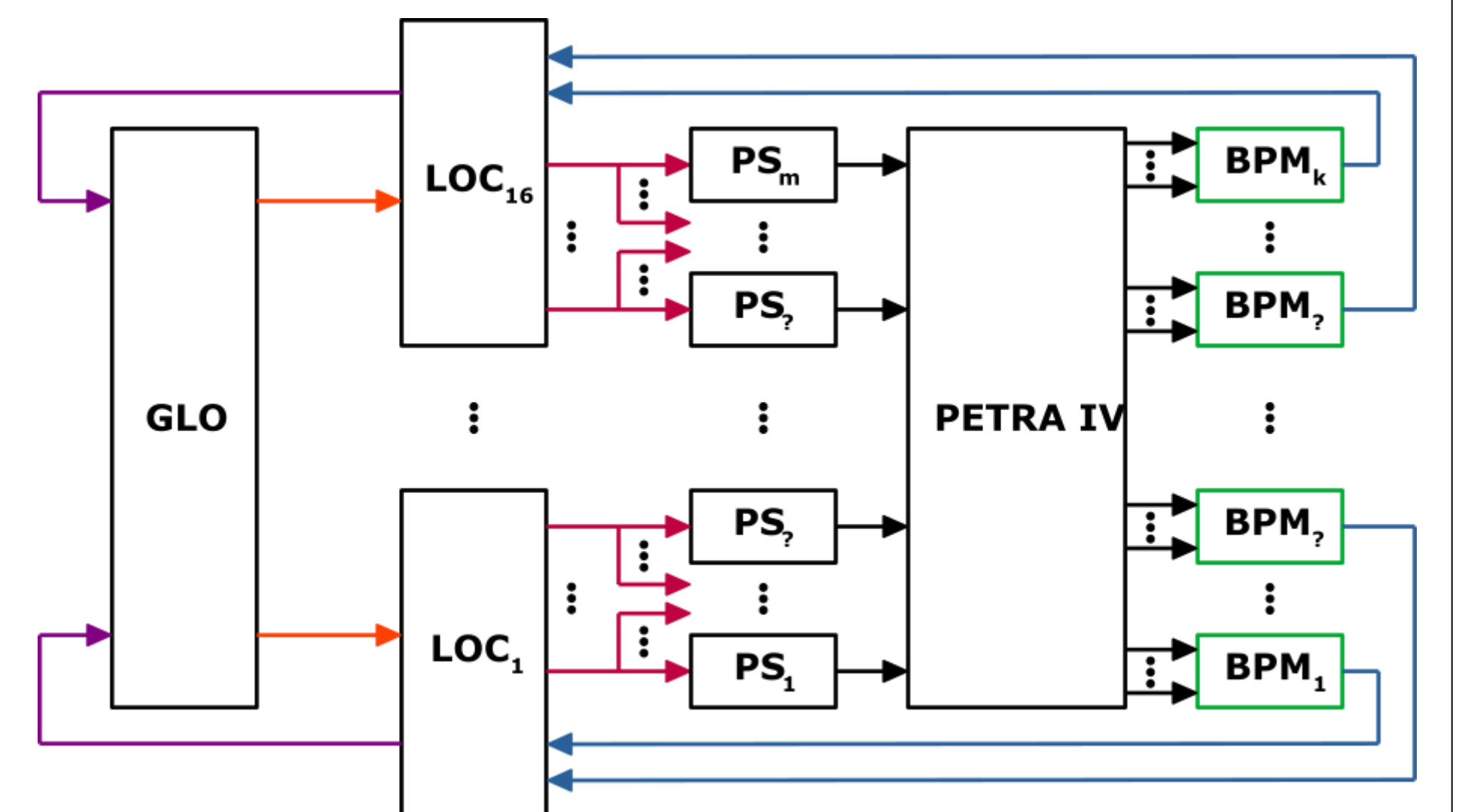

Simplified block diagram for central data processing around the PETRA IV ring. Optical communication links, displayed as colored lines, from up to k=789 BPMs via up to 16 LOCs and 1 GLO to about 522 PSs, locally distributed over the corresponding LOC

Analytical modelling of subsystems

BPMs

BPM electronics is based on Libera Brilliance+ system providing turn-by-turn data with a resolution of at least 100 nm and an update rate of 130 kHz. A maximum latency of 3 turns, i.e. 23 μs .

Cable and corrector magnets

All 3 horizontal and 2 out of 4 vertical fast correctors per cell (in the current lattice of PETRA IV) overlap the locations of slow correctors. So the combined AC/DC corrector magnet design is proposed capable of 800 μrad DC deflection and 30 μrad integrated deflection up to 1 kHz. The aperture diameter of 25 mm and length no longer than 150 mm are the design parameters from the lattice point-of-view. The proposed design is based on the layout of the 8-pole corrector magnet for APS-U. This layout allows improved field quality for both deflection planes, created by the main and auxiliary coils. Cables with lengths up to 200 m are required between the corrector power supplies and the magnets to keep the power electronics outside the tunnel. This puts special demands on the cable itself, like low losses, radiation hardness and cable-magnet resonance. A notch at 8.3 kHz is observed in simulations in the source current. The notch creates an uncertainty between source and magnet current in frequencies around notch. Hence, a closed-loop current controller shall be limited to a few hundred Hz.

$$f_{\text{res}} = \frac{1}{2\pi\sqrt{L_{\text{mag}}C_{\text{cable}}l_{\text{cable}}}}$$

$$f_{\text{peak}} = \frac{cN_{13,5\dots}}{4\sqrt{\epsilon_r}\mu_r l}$$

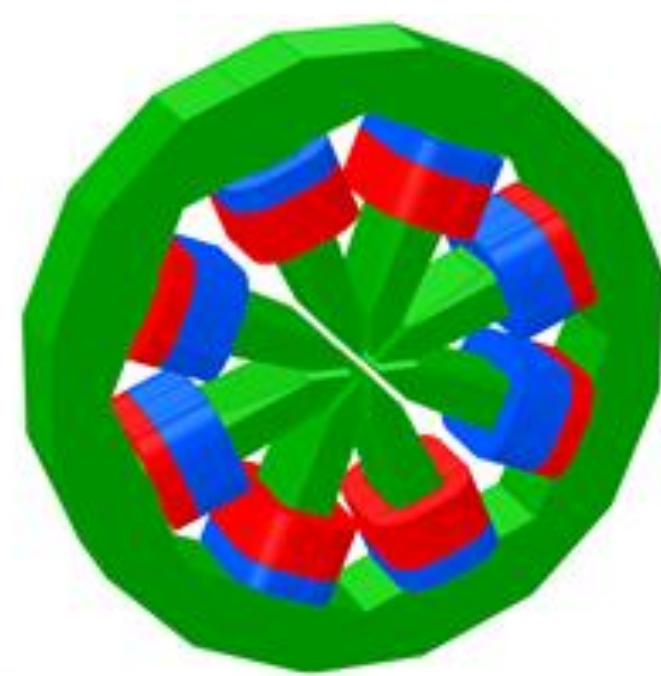

Combined corrector layout. The main and auxiliary coils are represented by inner and outer coils, respectively, with blue representing horizontal and red representing vertical correctors.

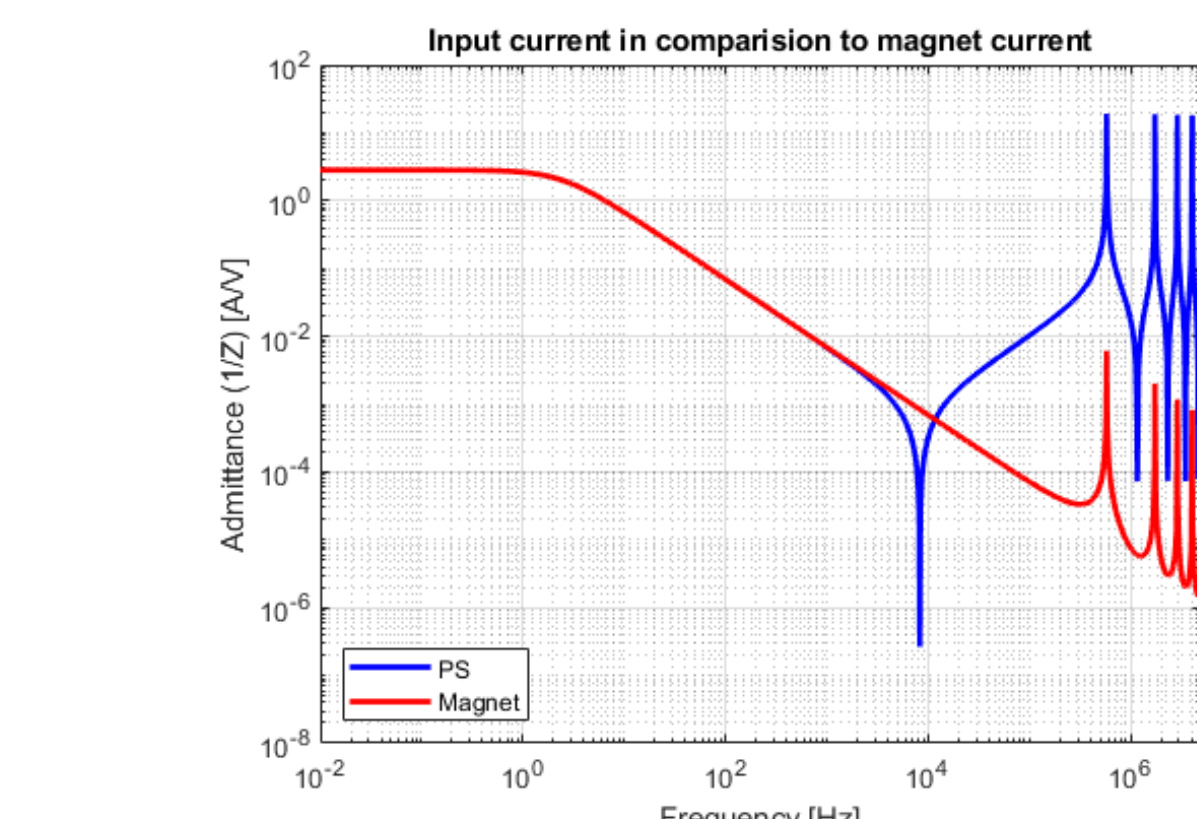

The notch in current in the coaxial cable connected with magnet coil, at 8.3 kHz seen by the source point of view

Corrector power supply

Design not finalized yet, but the considered option includes two paths: slow regulation (feedback based) up to a maximum of a few hundred Hz for mainly slow drift compensation and fast uncontrolled (feed-forward) action for fast corrector to overcome mismatch in the current readback using DCCT at PS output. This solution provides low latency, the update rate of 130 kHz, no feedback but a lead-lag component is required for the fast corrector coil to reach at least 1.3 kHz open-loop BW.

Vacuum chamber

A low-pass filter behavior attenuating the magnetic field inside the chamber. If the skin depth of material is larger than the thickness of the chamber, its response can be modelled as a first order filter. 1 mm thick stainless steel chamber of radius 10.5 mm (BW=17.8 kHz), contrary to the alternate option of copper (BW=770 Hz, for 0.5 mm thickness). Remark: inner coating ignored yet.

$$G_{\text{vac}} = \frac{\omega_0}{s + \omega_0}$$

$$\omega_0 = \frac{1}{\tau} = \frac{1}{2}\mu_0\sigma a d$$

a = radius of pipe
 d = thickness of pipe
 σ = conductivity

Orbit response matrix

$$R_{mn} = \frac{\sqrt{\beta_m\beta_n}}{2\sin(\pi Q)} \cos(Q\pi - |\mu_m - \mu_n|)$$

where β and μ denote the beta function and phase advance at BPM and corrector locations marked as m and n , respectively, in the given plane. Q is the coherent Betatron tune of the synchrotron. The condition numbers of fast ORMs are 322.8 and 765 for horizontal and vertical planes, respectively.

Betatron oscillations

The update rate for FOFB system = 130 kHz. Betatron frequencies $\nu_x = 23.43$ kHz and $\nu_y = 35.156$ kHz need to be included into modeling. The transfer function model for Betatron excitation is,

$$H_{mn} = \sqrt{\beta_m\beta_n} \text{Im} \left(\frac{e^{j(\mu_m - \mu_n)}}{s + \frac{1}{\tau} - j\nu} \right) \quad H = \frac{p_1 p_2}{(s - p_1)(s - p_2)} \quad p_i = -\left(\frac{1}{\tau} \pm j\omega_i\right)$$

$$\tau_x = 17 \text{ ms}, \tau_y = 22 \text{ ms} \text{ (without multi-bunch feedback)}$$

Synchrotron oscillations

$$x_D = \frac{\Delta P \sin(\Omega t)}{P_0} D, \quad \Omega = 600 \text{ Hz}$$

Synchrotron frequency lies within the bandwidth of PETRA IV FOFB system. But not included yet in these simulations.

SISO simulation

A first-hand estimation of the full-loop transfer function and delay budget is made for the longest path from LOC to GLO stations. An open-loop BW of 1.26 kHz and a delay of 83 μs ($\tau_{d,\text{BPM}} = 23 \mu\text{s}$, $\tau_{d,\text{controller}} = 30 \mu\text{s}$, $\tau_{d,\text{LOC-GLO}} = 15 \mu\text{s}$, $\tau_{d,\text{PS-cable}} = 15 \mu\text{s}$).

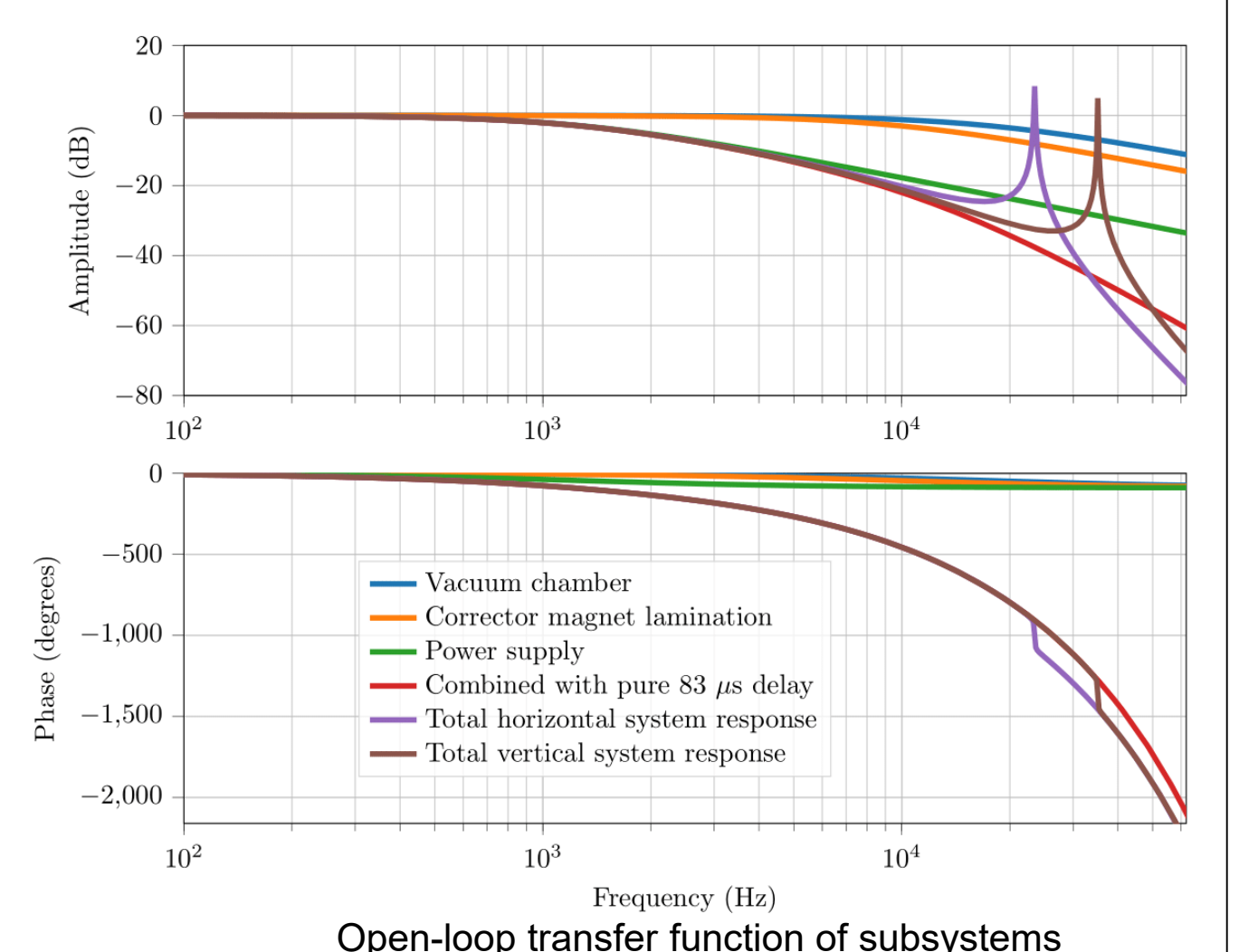
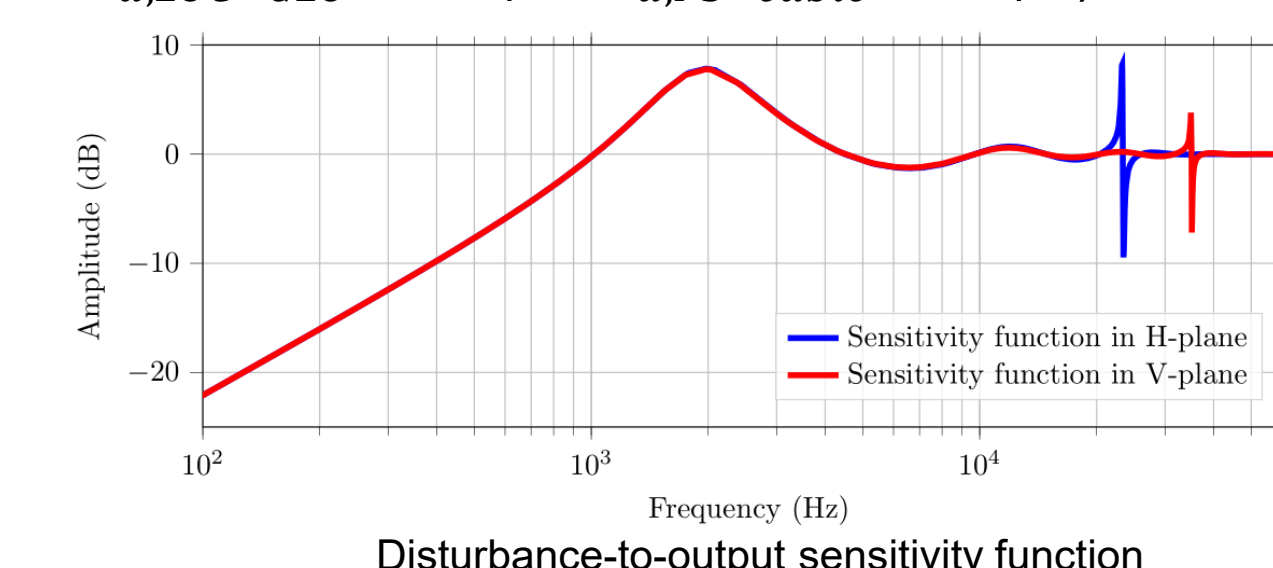

Summary and outlook

In this paper, a preliminary analysis of requirements and proposed topology for global FOFB system for PETRA IV is presented. Analytical subsystem modeling is also presented in order to evaluate the feasibility 1 kHz disturbance rejection bandwidth. The interaction of FOFB system with the synchrotron oscillations shall be studied as a next step.

References

- [1] I. Agapov et al, PETRA IV storage ring design, 13th IPAC22 (TUPOMS014), Bangkok, Thailand
- [2] G. Rehm, Achieving and measuring sub-micrometer beam stability at 3rd generation light sources, J. Phys. Conf. Ser. **425**, 1 (2013)
- [3] T. Hellert et al, Error analysis and commissioning simulation for the PETRA IV storage ring, 13th IPAC22 (TUPOMS018), Bangkok, Thailand
- [4] M. Jaski, APS Upgrade: Magnets, ASD Seminar, Apr. 2017
- [5] Yao Cheng, Dynamic closed orbit correction, Proceedings of ICPA, 1993, pp. 2269-2271 vol.3
- [6] B. Podobedov et al, Eddy current shielding by electrically thick vacuum chambers, Proceedings of PAC09 (TH5FP083), Vancouver, Canada
- [7] P. Paglovec et al., "The RF BPM Electronics Concept and Developments for the PETRA IV project at DESY", MicroTCA Workshop (DESY), 2021
- [8] P. Kallakuri et al., "Coupled bunch mode zero correction using orbit measurements and rf system phase feedback", Phys. Rev. Accel. Beams **25**, 082801 (2022)

*Corresponding author: sajjad.hussain.mirza@desy.de

