

P. Anger †, C. Berthe, F. Bucaille, V. Desmezières, C. Haquin, C. Jamet, S. Leloir, G. Normand, J.C. Pacary, S. Perret-Gatel, A. Savalle  
GANIL Laboratory (Caen -France)

e-mail : anger@ganil.fr

## Abstract :

The SPIRAL2 facility at GANIL is based on the construction of a superconducting ion CW LINAC (up to 5 mA - 40 MeV deuteron beams and up to 1 mA - 14.5 MeV/u heavy ion beams) with two experimental areas called S3 and NFS. The building, the accelerator and experimental equipment studies started in 2009. For safety-classified system using beam intensity monitoring, SPIRAL2 project system engineering sets up a specific reinforced process, based on V-Model, to validate, at each step, all the requirements (technical, nuclear safety, quality, reliability, interfaces...) from the functional specifications to the final validation.

Since 2016, the main part of the safety devices is installed and is currently under testing. These tests which are pre-requisites to deliver the first beam will demonstrate that both functional and safety requirements are fulfilled.

This contribution will describe the requirements (operation field, limitation of equipment activation...), the technical studies, the failure mode and effects analysis, the tests, the status and results of the SPIRAL2 Machine Protection System using AC and DC current transformers to measure and control the beam intensity.

## SPIRAL2 Project Phases:

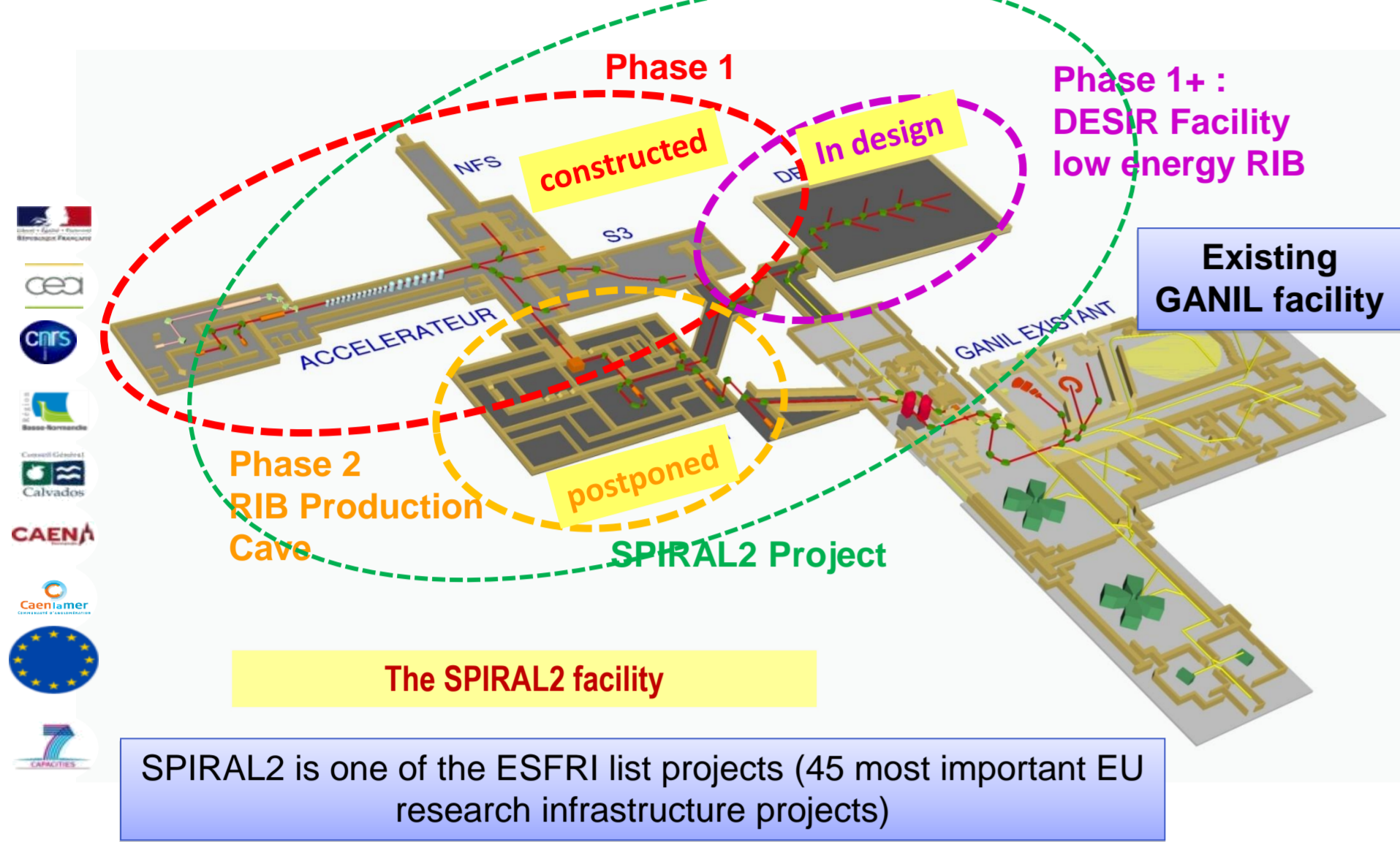

## SPIRAL2 Project Phase 1

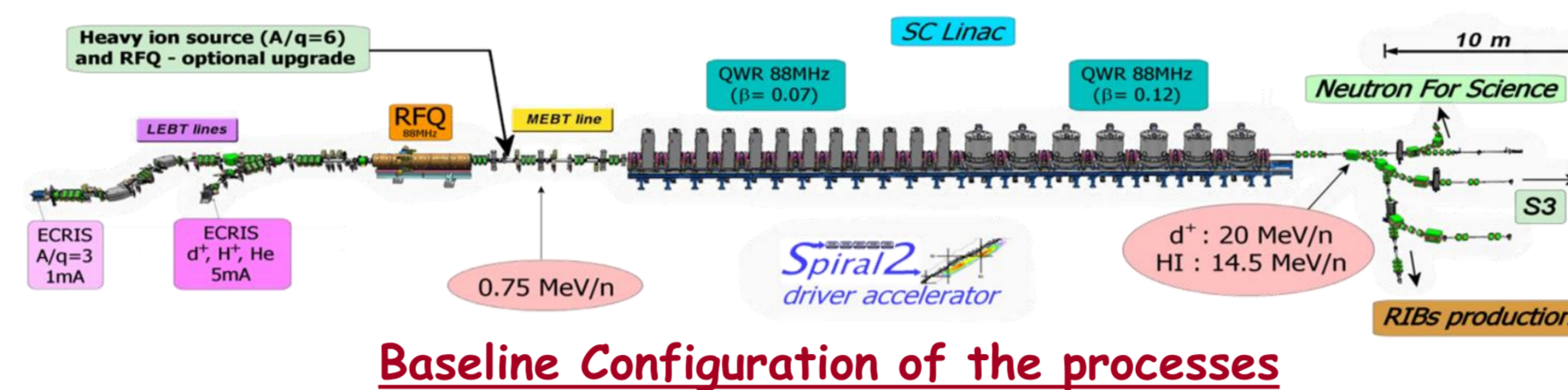

Beam	P	D <sup>+</sup>	Heavy Ions
Max. Intensity	5 mA	5 mA	1 mA
Max. Energy	33 MeV	20 MeV/A	14.5 MeV/A
Max. Power	165 kW	200 kW	45 kW

Beam Specifications

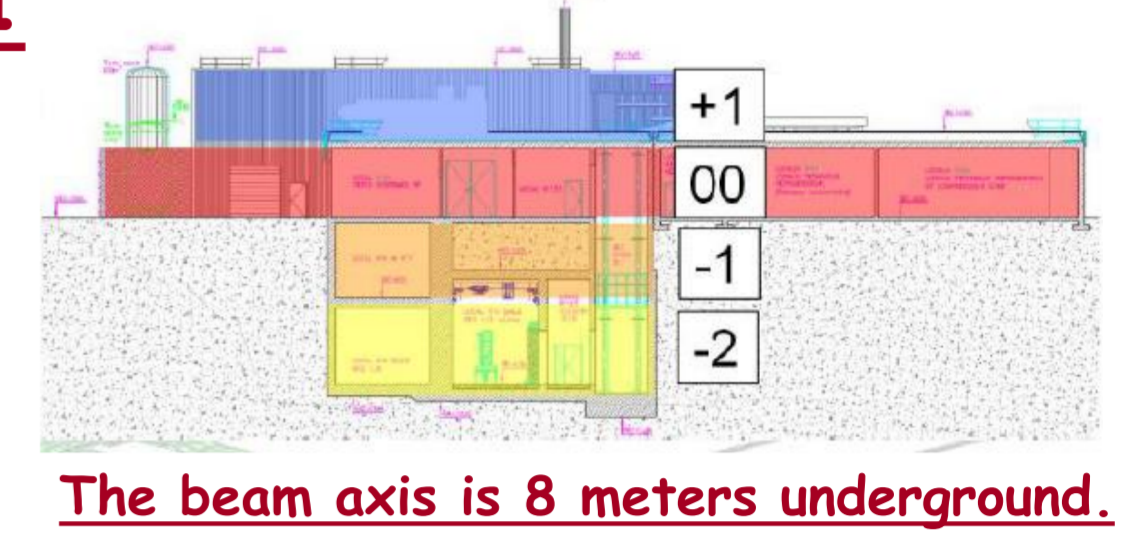

The beam axis is 8 meters underground.



Completion of the SPIRAL2 building (October 2014).

## Problematic :

The SPIRAL2/GANIL facility is considered as an "INSTALLATION NUCLEAIRE DE BASE" (INB), French administrative denomination.

The classification of the SPIRAL2/GANIL facility in the INB field is due to the characteristics of the beams at the last acceleration state

### Goals :

- to protect workers, public and environment against all risks identify
- to reduce as low as possible frequencies and consequences of incidents and accidents.

Concrete building (14.000m<sup>3</sup>) with the 8 meters underground beam axis : not sufficient for protection against external exposure to ionizing radiation

### Needs :

- control the accelerator device activation due to beam losses (beam losses limited to 1W/m for D+ beams)
- control the target and Beam dump activation
- control the operating range

**Objective :** control the beam power and losses with a dedicated and classified-safety Machine Protection System (MPS).

## Methodology :

### Based on system engineering management :

- structuring approach for a complex project
- focus on the needs definition for the customer and for the functional requirements,
- V-cycle (documenting the requirements, continuing with the synthesis of the conception (design), realization and the validation of the system)

### Using a specific Quality Management Plan for the Safety (PMQS) :

Dedicated task force to check at each breakpoint or reviews of the V cycle :

- independent technical validation,
  - a nuclear safety control,
  - an independent dependability checking (Failure Mode and Effects Analysis),
  - a validation of the integration in the building and the interface conformity with the other processes,
  - a quality and documentation checking.
- with compliance of French decree for nuclear facility)

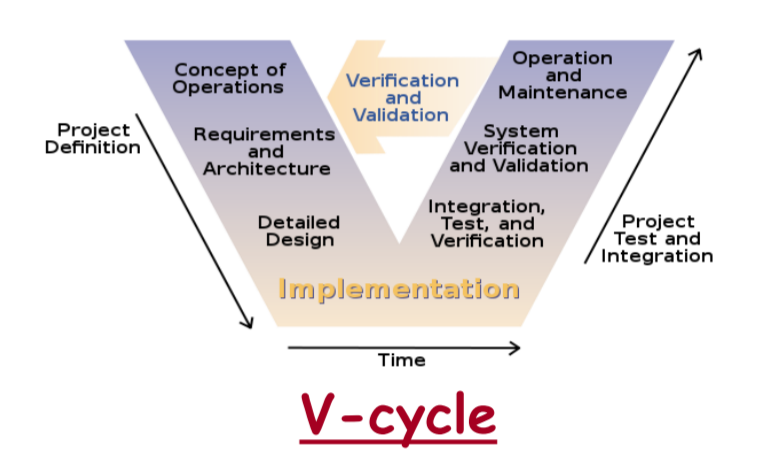

V-cycle

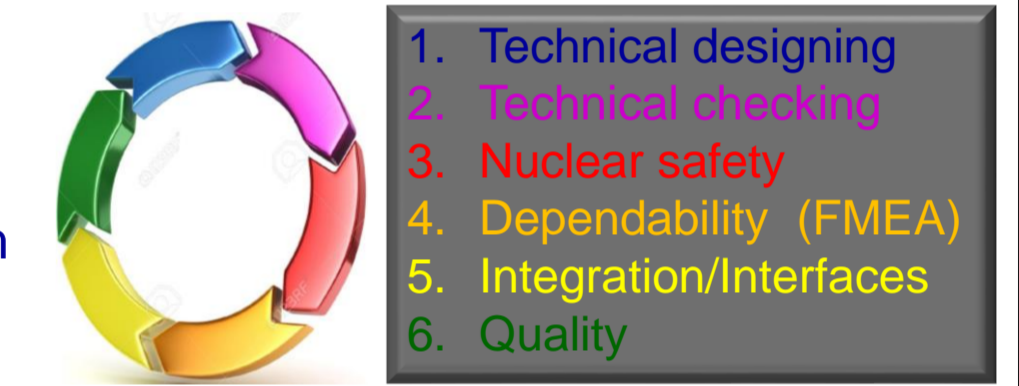

Chain for Safety Quality Management Plan

## Beam intensity monitoring subsystem:

2 types of non-destructive beam intensity monitors :

- DCCT (Bergoz NPCT-175-C030-HR)
  - Homemade ACCT (A nanocrystalline torus with turns ratio of 300:1)
- This 2 types are justified by the difference of detection principles and by their complementarities

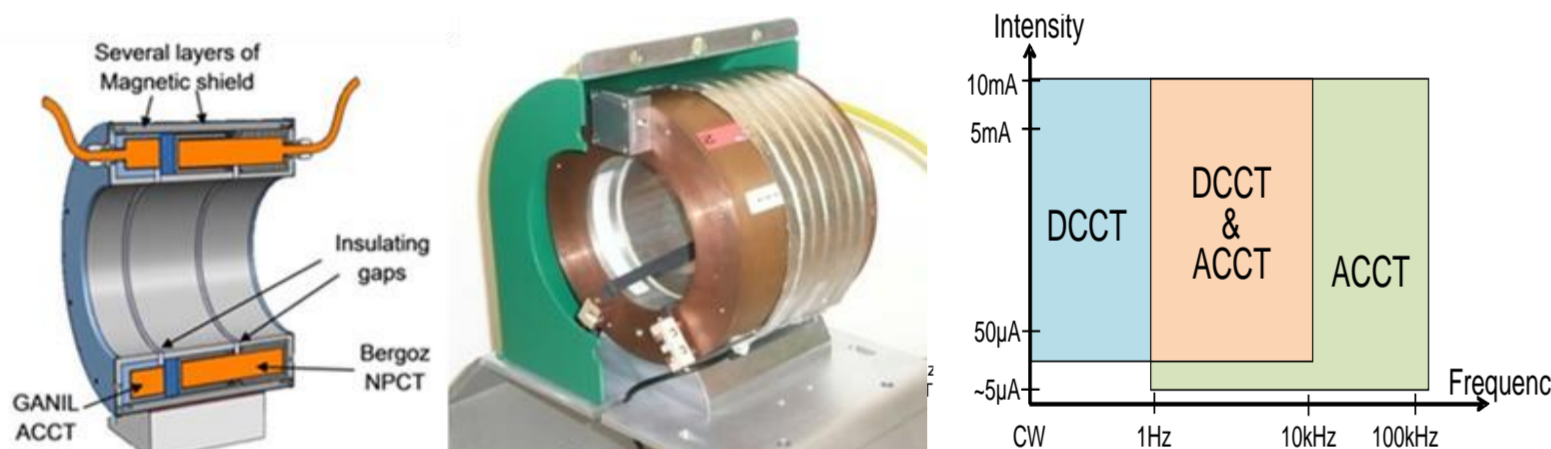

ACCT/DCCT bloc section and operating range

- The DCCTs measure the intensity of continuous and chopped beams with a slow response time (about 50  $\mu$ s for a bandwidth of 10 kHz). The minimum intensity that can be measured is few 10  $\mu$ A due to the offset level
- The ACCTs are faster with rise times about 1  $\mu$ s and with minimum levels less than 5  $\mu$ A.

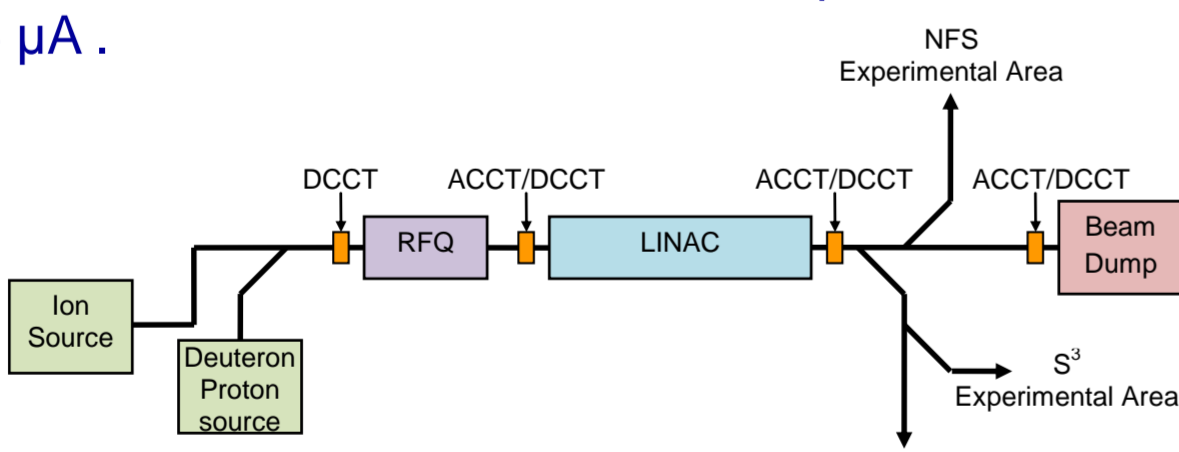

Intensity measurement locations

- Signal conversion into a pulse frequency. Use of counter.
- The counter value is equal to the threshold value minus the integrator value. The threshold values must take into account the qualified uncertainty measurement.
- If counter value is null : generation of beam cut alarm signal

## Control subsystem of the beam dump activation:

- Operation requires the possibility of human intervention on the Linac Beam Dump and its surrounding.
- Beam Dump activation remain < an acceptable threshold
- Threshold expressed in number of particles that can be dropped into the Beam Dump during a 24 hours time frame.

### Shortest times according the beam power after which the threshold is reached :

Beam Power	Time to reach the threshold
200 kW	3 minutes
10 kW	1 hour
417 W	Always below threshold
Worst Cases (20 MeV/A deuteron beam)	

- The subsystem integrate the number of particles over a 24 h period from the beam intensity monitoring (ACCT/DCCT) taking into account the ion charge.
- As soon as 95 % of the threshold is reached, a beam cut-off request is sent to the beam cut treatment subsystem.



- Taking into account the safety and reliability requirements, the LabVIEW technology using the cRIO (Compact Reconfigurable Input Output) solution with FPGA (Field-Programmable Gate Array) in its backplane was selected for the subsystem and proved its reliability.
- Redundancy and auto-test were implemented.
- To ensure that the system is alive, a watchdog is monitored by an external cycle monitor able to request a beam cut off if the system is out of order.

## Beam cuts treatment subsystem:

- This safety-classified subsystem is the core part of the SPIRAL2 Machine Protection System (MPS);
- it is a simple and secured one, based on a PLC with a hard-wired system.
- This system relies in particular on the following diagnostics based subsystems:
  - The monitoring of radiation produced by beam losses (ACCT/DCCT monitor and scintillation monitor)
  - The operating range control of the facility (ACCT/DCCT monitor),
  - The Linac beam dump integrity controlling set (Control subsystem of the beam dump activation and cooling subsystem)
- It receives alarms from beam losses monitors, beam intensity, beam dump and targets control parameters.
- Therefore, it activates the beam cut through commands sent to safe and slow beam stops in the low energy beam line (response time: 1.5 s) in association with a temporary RF stop on the RFQ (response time: 1  $\mu$ s).

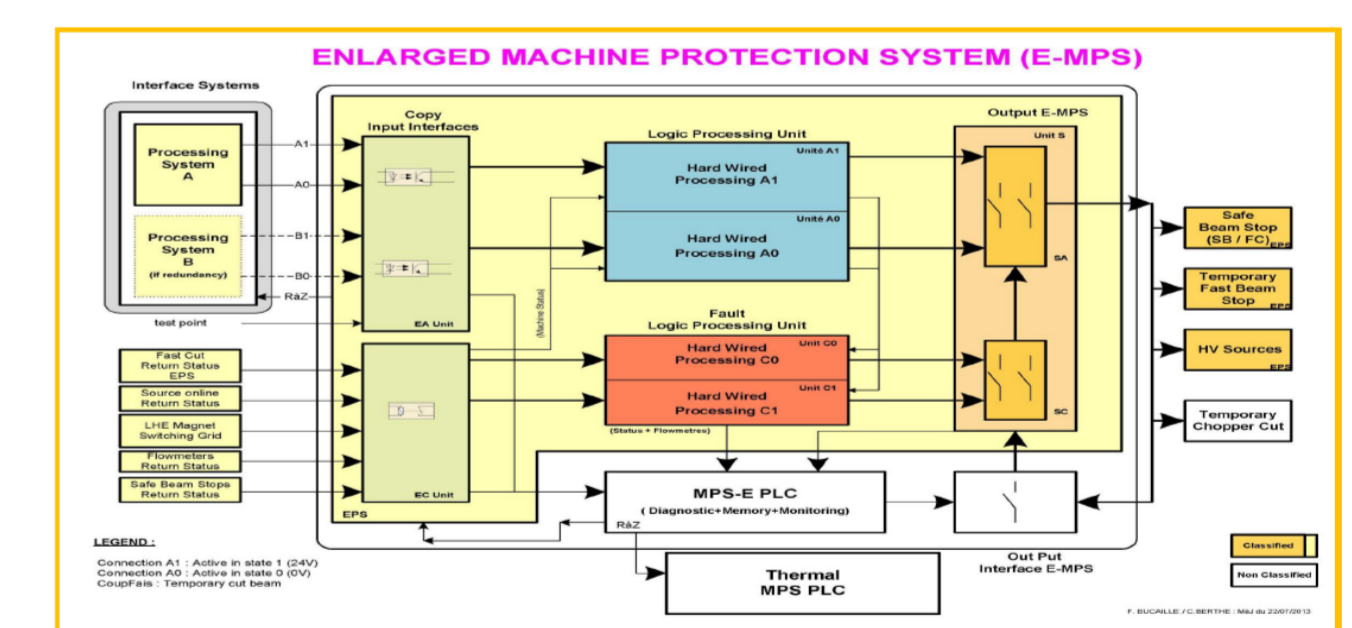

Redundant hard-wired system

- The response time was determined by the thermal and activation calculations with safety margin. The expected response times are for the fastest 15 ms (10 ms for the detection, 4 ms for the treatment and 1 ms for the beam cut) to a few seconds for slower ones

## Tests and safety validations :

- Every subsystems and electrical connections are realized, integrated and installed since 2018.
- For each subsystem, the second phase of the V-cycle has been respected. This concerns the followings:
  - unit tests,
  - subassembly tests and overall test,
  - functional tests
  - tests in a degraded situation according to the Failure Mode and Effects Analysis (FMEA) during the design phase.

- Each deviation from the validated design reference requires analysis, processing and validation by the six links of the chain for Safety Quality Management Plan (PMQS).
- After iteration and complete agreement of the six links, the modifications are carried out with a updating of the different references (diagrams, files, FMEA ...).
- A safety-specific quality summary file is completed to prepare the operation phase and to be potentially audited during inspections by the nuclear safety authority.
- To complete the validation of each subsystem, a final global testing of the Machine Protection System (MPS), without beam, is scheduled in September 2019 before allowing the beam acceleration in October 2019.
- During the Linac commissioning, as the beam ramps up, additional validations with beam will be conducted in 2019 and 2020.

## Conclusions :

- The classified safety Machine Protection System with all subsystems is now installed, tested and individually validated.
- Final and global validation is in progress to allow the Linac beam commissioning next month.

For the safety-classified system using beam intensity monitoring in order to respect the nuclear requirements of SPIRAL2 facility, our main feedback concerns the followings:

- The required very low beam intensity level for the detection of ACCT/DCCT (in the order of a few  $\mu$ A) integrating the definition of global uncertainties is brilliantly achieved through a specific development for SPIRAL2.

- The ACCT/DCCT monitor architecture, the control subsystem of the beam dump activation with cRIO and the beam cuts treatment subsystem (with optoelectronic relay and PLC) have progressed to be very reliable and have been hardened by Failure Mode and Effects Analysis (FMEA) through the use of principle like redundancy, dissimilarity, simplification, auto-testing and degraded mode studies
- The short subsystem response times (few ms) have been validated
- The V-cycle time is long between the start of the design in 2013 and the overall validation in 2019 because time is the only adjustment variable. There has been no change in the technical, safety and cost requirements.
- Many human resources are needed to achieve safety and quality requirements

- The goal is reached: Producing, with a multidisciplinary team, a complex instrumentation meeting the SPIRAL2 safety and quality requirements is a technical and human challenge that the SPIRAL2 project has raised.
- Such as Needs = Such as designed = Such as installed