

# BEAM INSTRUMENTATION CHALLENGES FOR THE FERMILAB PIP-II ACCELERATOR\*

V. Scarpine<sup>†</sup>, N. Eddy, D. Frolov, M. Ibrahim, L. Prost, R. Thurman-Keup  
 Fermi National Accelerator Laboratory, Batavia, IL USA

## Abstract

Fermilab is undertaking the development of a new 800 MeV superconducting RF linac to replace its present normal conducting 400 MeV linac. The PIP-II linac warm front-end consists of an ion source, LEBT, RFQ and MEBT which includes an arbitrary pattern bunch chopper, to generate a 2.1 MeV, 2mA H- beam. This is followed immediately by a series of superconducting RF cryomodules to produce a 800 MeV beam. Commissioning, operate and safety present challenges to the beam instrumentation. This paper describes some of the beam instrumentation choices and challenges for PIP-II.

## THE PIP-II ACCELERATOR

The PIP-II project at Fermilab is building a superconducting Linac to fuel the next generation of intensity frontier experiments [1]. Capitalizing on advances in superconducting radio-frequency (SRF) technology, five families of superconducting cavities will accelerate H<sup>-</sup> ions to 800 MeV for injection into the Booster. Upgrades to the existing Booster, Main Injector, and Recycler rings will enable them to operate at a 20 Hz repetition rate and will provide a 1.2 MW proton beam for the Long Baseline Neutrino Facility. Table 1 list keep beam parameters for PIP-II.

Table 1. PIP-II Beam Parameters

Linac	PIP-II
Delivered Beam Energy (kinetic)	800 MeV
Particles per Pulse	$6.7 \times 10^{12}$
Average Beam Current in the Pulse	2 mA
Pulse Length	550 μs
Pulse Repetition Rate	20 Hz
Bunch Pattern	Programmable
Booster	Value
Injection Energy (kinetic)	800 MeV
Extraction Energy (kinetic)	8 GeV
Particles per Pulse (extracted)	$6.5 \times 10^{12}$
Beam Pulse Repetition Rate	20 Hz
Recycler Ring / Main Injector	Value
Injection Energy (kinetic)	8 GeV
Extracted Beam Energy	60-120 GeV
Beam Power (120 GeV)	1.2 MW
Cycle Time (120 GeV)	1.2 sec
Upgrade potential	2.4 MW

\* This work was supported by the U.S. Department of Energy under contract No. DE-AC02-07CH11359.

<sup>†</sup> email address: scarpine@fnal.gov

Figure 1 shows the layout of the SC Linac [1], The β values represent the optimal betas where the corresponding cavity delivers the maximum accelerating voltage. A room temperature (RT) section accelerates the beam to 2.1 MeV and creates the desired bunch structure for injection into the SC Linac. In the SC section of the linac, strict particle-free and high-vacuum requirement place limitation on the design and type of beam instrumentation that can be used.

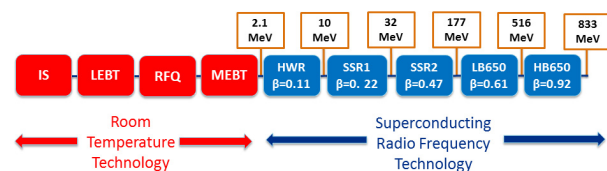

Figure 1: The PIP-II SC Linac technology map.

## THE PIP-II INJECTOR TEST FACILITY

The PIP-II R&D strategy is designed to mitigate technical and cost risks associated with the project. One part of this strategy is to develop and operational test the PIP-II Front End covering the first 20 MeV in the PIP-II Injector Test (PIP2IT) facility [2].

The PIP2IT program will develop and perform an integrated system test of the room temperature warm front end (WFE), consisting of the ion source, LEBT, RFQ and MEBT [3], and the first two superconducting cryomodules. The ion source and LEBT operate with 30 keV H- beam up to 10 mA and the MEBT operates with 2.1 MeV H- beam up to 5 mA. The hardware layout is shown in Figure 2.

In addition, the MEBT section of the WFE operates a bunch-by-bunch chopper allowing for any arbitrary beam pattern [4]. For PIP-II beam operations, the chopper will reduce the beam current from 5 mA to 2 mA before injection into the SC linac.

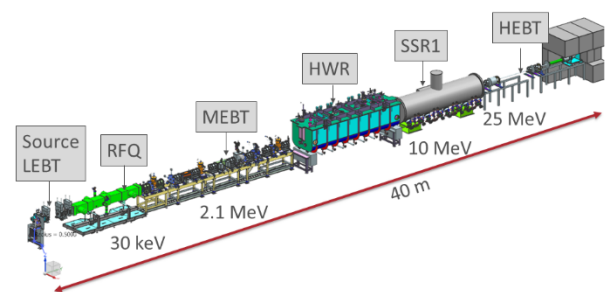

Figure 2: The beamline layout of the PIP-II Injector Test.

The warm front-end has a number beam diagnostic instruments to help prepare beam for the SC linac. Figure 3 shows the beamline layout of the PIP2IT WFE MEBT used for commissioning the MEBT.

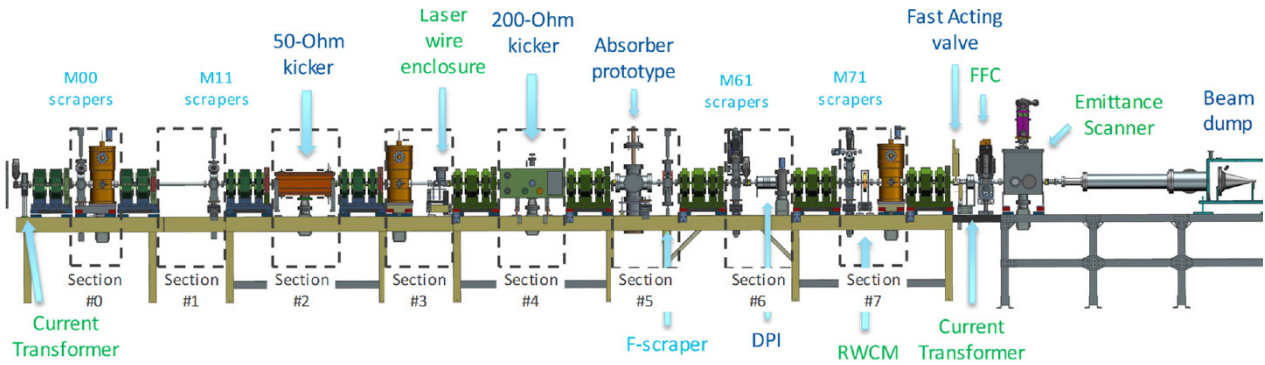

Figure 3: PIP2IT MEBT beamline before cryomodule installation.

### WFE Emittance Monitors

A standard emittance measurement technique for lower energy ions are based on an Allison-style emittance monitor [5]. In the PIP2IT LEBT, transverse emittance and details of the ion distribution in the phase space are extracted from measurements with an Allison-style scanner [6]. This emittance monitor is located at the output of the ion source. In addition, Fermilab has constructed an Allison-style emittance monitor for the MEBT operating with 2.1 MeV H<sup>-</sup> beam. Because of the higher energy beam, the MEBT emittance scanner is limited to  $\pm 12$  mrad of angular range. Figure 4 shows a typical phase space measurement and emittance analysis results. Figure 3 shows this emittance monitor located at the end of MEBT for commissioning. After installation of the HWR cryomodule, the emittance scanner will be moved to section 1 of the MEBT.

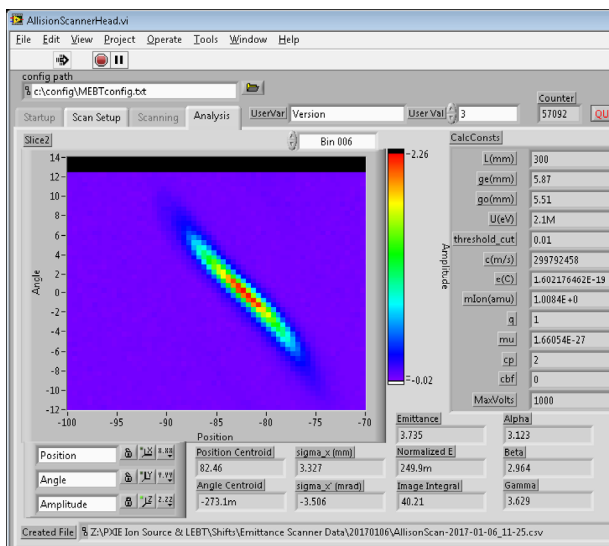

Figure 4: Beam phase space measurement in the MEBT.

### MEBT Beam Chopper Measurements

As mentioned earlier, the PIP-II MEBT will employ a bunch-by-bunch chopper allowing for the construction of any arbitrary beam pattern [4]. To monitor the chopping efficiency and chopper pattern, the MEBT utilizes a wall current monitor (WCM) to measure the chopped beam [7]. Figure 5a shows the WCM in the PIP2IT MEBT and Figure

5b show the frequency response for this detector. Figure 6 shows a measurement of PIP2IT before and after the MEBT chopper. Measurements of chopper efficiency with the WCM are to level of  $\sim 0.002$  and is limited mostly by small reflections from connectors in the signal cable.

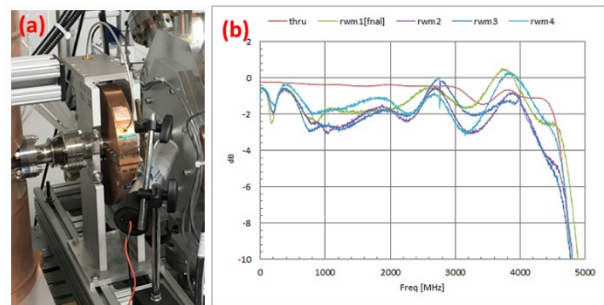

Figure 5: (a) WCM installed in PIP2IT MEBT and (b) high-frequency response of WCM.

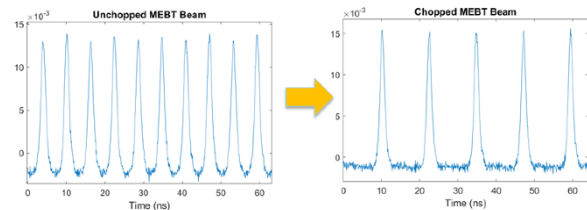

Figure 6: Measurements of unchopped and chopped PIP2IT MEBT beam.

## PIP-II BEAM DIAGNOSTICS

Various beam instrumentation and diagnostics systems are necessary to characterize and monitor the beam parameters and the performance of the PIP-II accelerator. Startup and initial beam commissioning will require, at a minimum, beam instruments to observe:

- Beam intensity and current – ACCTs and DCCTs
- Beam position / orbit – Warm and cold 4-button BPMs
- Transverse beam profiles – laser wire and wire scanners
- Beam phase / timing - BPMs
- Beam loss – ionization, PMT scintillator and neutron detectors

Beside these core beam instrumentation systems, additional beam diagnostics will be utilized to characterize such beam parameters as the beam emittance, longitudinal bunch profile, transverse beam halo and bunch-by-bunch chopping efficiency. When possible, the beam instrumentation and diagnostics systems must be able to operate over a wide bandwidth from  $\sim 5 \mu\text{s}$  pulses for machine commissioning and tuning to  $\sim 550 \mu\text{s}$  operational pulses.

In addition, to protect the superconducting cavities in the linac, strict particle-free and ultra-high vacuum rules must be followed for all beam instrumentation. This places restriction on the design and choice of instruments.

### Laser Wire Profiling

Because of the particle-free restrictions in the SC linac, the choice of beam profiling instruments is limited. Fortunately, the PIP-II linac accelerates H<sup>-</sup> ions and can therefore utilize laser induced photoionization ( $\text{H}^- + \gamma \rightarrow \text{H}^0 + \text{e}^-$ ) to measurement beam profiles [8]. Therefore, PIP-II will use laser-based beam profiling in the SC linac.

In order to reduce the danger of laser induced damage to optical vacuum windows and to eliminate free-space transport of laser light, PIP-II is investigating the option of using a low-power fiber laser with all-fiber optical transport through the linac [9]. The fiber laser will operate at the PIP-II bunch repetition rate of 162.5 MHz inducing a small number of photoionization per bunch. To improve the signal detection, the laser pulses will be amplitude modulated to allow detection of the modulation frequency using lock-in amplifier techniques. Figure 7 shows a block diagram of the prototype laser profiling system. To minimize the design risk, this system will be tested at PIP2IT.

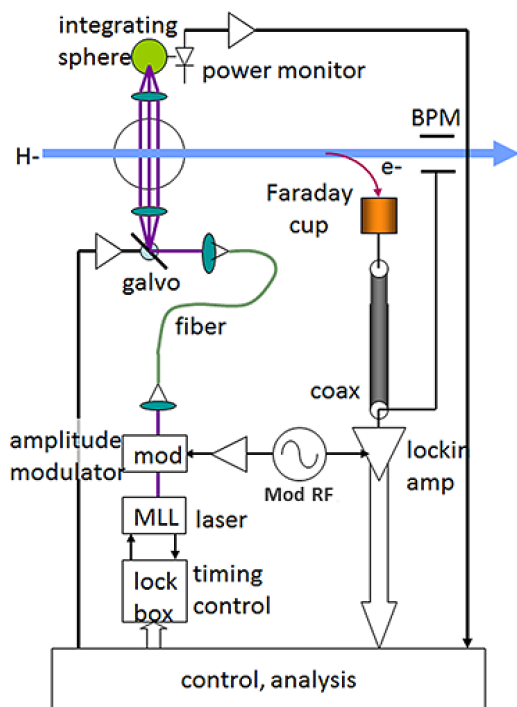

Figure 7: Block diagram of low-power fiber-based laser profile system.

### SUMMARY

Fermilab is constructing a new 800 MeV superconducting linac as part of its PIP-II upgrade. Beam instrumentation to support commissioning and operation of the linac have been discussed. Exploration of instrumentation, such as a MeV Allison-style emittance scanner, a WCM chopper pattern detector and a fiber-based laser profile monitor are presented.

### ACKNOWLEDGEMENTS

The authors would like to thank Matt Alvarez for his design and construction of the Allison emittance scanners, Alexander Shemyakin for his insight, expertise and analyses toward the construction and operation of the PIP2IT warm front end and Andrea Saewart and Brian Fellenz for their tireless effort toward instrumentation development at PIP2IT.

### REFERENCES

- [1] PIP-II Conceptual Design Report, 2018, <http://pip2-docdb.fnal.gov/cgi-bin/ShowDocument?docid=113>
- [2] P. Derwent *et al.*, “PIP-II Injector Test: Challenges and Status”, in *Proc. 28th Linear Accelerator Conf. (LINAC'16)*, East Lansing, MI, USA, Sep. 2016, pp. 641-645. doi:10.18429/JACoW-LINAC2016-WE1A01
- [3] L. R. Prost *et al.*, “PIP-II Injector Test Warm Front End: Commissioning Update”, in *Proc. IPAC'18*, Vancouver, Canada, Apr.-May 2018, pp. 2943-2946. doi:10.18429/JACoW-IPAC2018-THYGBF2
- [4] A. V. Shemyakin *et al.*, “Design of 162-MHz CW Bunch-by-Bunch Chopper and Prototype Testing Results”, in *Proc. HB'18*, Daejeon, Korea, Jun. 2018, pp. 428-433. doi:10.18429/JACoW-HB2018-THP1WC03
- [5] M. Stockli, R.F. Welton, R. Keller, M. Leitner, *Review of Scientific Instruments* 77 (3) (2006).
- [6] R. D'Arcy *et al.*, “Characterization of the PXIE Allison-type emittance scanner”, *Nucl. Instrum. & Methods in Phys. Research A* 815 (2016), 7-17.
- [7] J. Crisp and B. Fellenz, “Tevatron Resistive Wall Current Monitor”, *JINST* 6 (2011) T11001.
- [8] Y. Liu *et al.*, “Laser Based Diagnostics for Measuring H-Beam Parameters”, in *Proc. PAC'11*, New York, NY, USA, Mar.-Apr. 2011, paper WEOCN1, pp. 1433-1437.
- [9] R. B. Wilcox, J. M. Byrd, M. S. Zolotarev, and V. E. Scarpine, “A Low-Power Laser Wire with Fiber Optic Distribution”, in *Proc. DIPAC'11*, Hamburg, Germany, May 2011, paper TUPD53, pp. 425-427.