

DEVELOPMENT OF COMPACT IONIZATION CHAMBERS FOR PARTICLE THERAPY FACILITIES*

M. Liu[†], C. X. Yin

Shanghai Synchrotron Radiation Facility & Shanghai Advanced Research Institute, Shanghai, China

Abstract

Dose monitors and position monitors are critical equipment for particle therapy facilities. Performance of the monitors affects precision of irradiation dose and dose distribution. Parallel plate ionization chambers with free air are adopted for dose monitors and position monitors. Radiation tolerant front-end electronics are integrated in the chambers, and the output of the chambers are digital signals. The structure of the monitors is compact and modularized. The ionization chambers are implemented successfully in Shanghai Advanced Proton Therapy Facility. The development details and implementation status are presented.

INTRODUCTION

Particle therapy facilities are dedicated accelerator facilities for cancer treatment. Compared with traditional radiotherapy, particle therapy has higher position accuracy transversely and longitudinally. In the course of treatment, radiation dose is mainly accumulated in malignant tumour. Cancerous cells are killed, while surrounding healthy tissue is spare. [1] During the delivery of radiation dose, beam parameters should be monitored in real time, especially in nozzle, which is the nearest part to patients.

Beam monitors are the core equipment of beam delivery system, by which beam from accelerator is converted to beam for treatment. The compact ionization chambers including front-end electronics were developed for particle therapy facilities. Parallel plate ionization chambers (PPIC) and multi-strip ionization chambers (MSIC, also a kind of PPIC) are used as the detectors, and radiation tolerant front-end electronics are designed to collect data and output digital signals.

Shanghai Advanced Proton Therapy Facility is under commissioning, which has a fix-beam room, a 180° gantry room and an ocular room. [2] The compact ionization chambers are implemented in the fix-beam room and the 180° gantry room. Both of the two rooms utilize active scanning technology for beam delivery. Compared with traditional passive scattering technology, the new technology has its advantages like providing more precise conformation [3], and yet raises more challenges to development of beam monitors.

SYSTEM DESIGN

For the nozzle which conducts spot-scanning dose delivery, scanning magnets moves particle beam discontin-

uously according to prescribed treatment plan. [4] Once preset dose value of current spot is reached, proton beam should be turned off and moved to next spot. The goal of irradiation is that the tumour receives a uniform dose distribution.

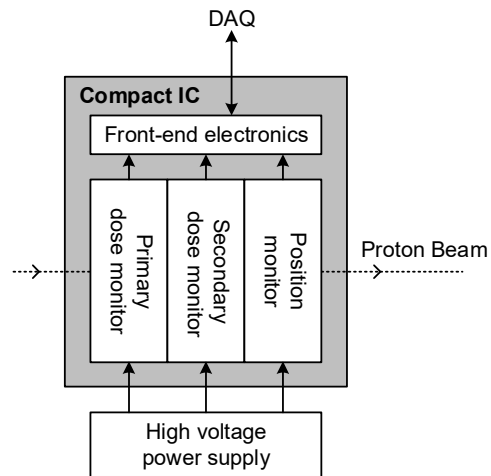

Figure 1: The structure of the compact ionization chambers.

The structure of compact ionization chambers is illustrated in Fig. 1. The dose monitors aim to achieve real-time dose measurement. The position monitor aims to achieve spot position and size measurement. Performance of the monitors affects treatment results severely. Characteristics of the beam monitors are shown in Table 1.

Table 1: Characteristics of the Compact Ionization Chambers

Parameter	
Dose relative accuracy	±2%
Dose relative resolution	±1% (2 sigma)
Dose data throughput	75kHz
Position accuracy	±0.5mm
Position resolution	±0.2mm (2 sigma)
Position data throughput	1.6kHz
Ion collection time	70 μs

Dose Monitor

Parallel plate ionization chambers with free air were used as the detectors of dose monitor, and the structure is illustrated in Fig. 2. The high voltage is -2500V. The material of the planes in PPIC is Kapton of 25μm, which is coated with Aluminium of 0.1μm. The gap between the high voltage plane and the signal pad is 5mm. According to spill strength range of the extracted beam, the collection efficiency is greater than 99%.

* Work supported by the Youth Innovation Promotion Association CAS (No. 2016238)

[†] liuming@zjlab.org.cn

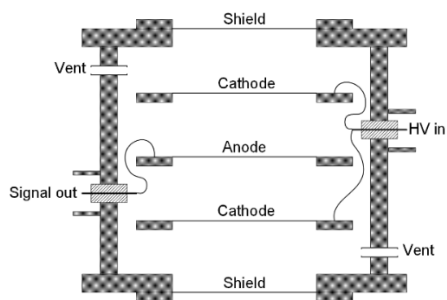

Figure 2: The structure of the dose monitors.

In consideration of safety, a primary dose monitor and a secondary dose monitor were installed for redundancy. The hardware structures of the two monitors are exactly the same. The primary dose monitor is used for real-time dose measurement and control. The secondary dose monitor has a slightly greater preset value than the primary dose monitor. In case of failures of the primary dose monitor, the secondary dose monitor triggers interlocks and turns off the beam.

Position Monitor

Multi-strip ionization chamber with free air was adopted as the detector, and the structure is illustrated in Fig. 3. The cathode strip planes for U direction and V direction share the same anode plane. The high voltage is 2000V. The gap between the high voltage plane and the signal strip pad is 5mm. The shield foil and the anode plane are made of the same material as dose monitors. The material of the cathode planes for U direction and V direction is Kapton of 25µm coated with copper. Both of the two cathode planes are manufactured using printed circuit board (PCB) technology.

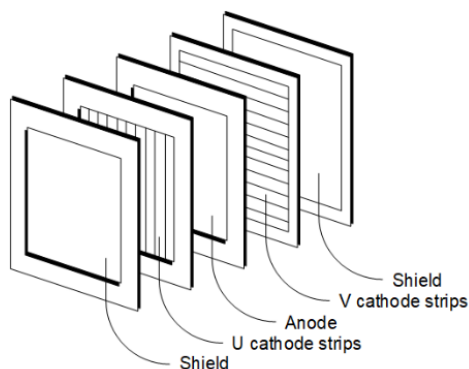

Figure 3: The structure of the position monitor.

The profile of one beam spot covers multiple strips in each direction. Output signals of these channels are used for calculation of position and size of the spot.

Front-end Electronics

The traditional method of front-end electronics for PPIC is recycling capacitor integration and voltage-to-frequency conversion. The method has a dead-time issue, which causes inaccuracy of accumulated dose. In the design of the compact ionization chambers, we adopted the method of current-to-voltage conversion and numeri-

cal integration. A trans-impedance amplifier converts current signal from PPIC to voltage. After that, an analog-digital converter (ADC) digitizes the voltage. [5] The digital signal is transmitted to DAQ system and integrated there in time domain. In this way, the accumulated dose is obtained.

In order to achieve long-term stability of the front-end electronics, all of the trans-impedance amplifiers, the resistors for the amplifiers and the voltage reference chips for ADC have low temperature-drift coefficients.

For position monitor, currents from multiple channels of strips are processed in the same way. Gravity method and Gaussian fitting method are two options to calculate beam center and beam size.



Figure 4: The integrated front-end electronics.

The front-end electronics are integrated in the compact ionization chambers, as illustrated in Fig. 4. Due to the irradiation environment, all chips and printed circuit boards are shielded with copper. Environmental parameters, including temperature, humidity and air pressure inside the chambers, are monitored to guarantee the validity of measurements. The digitized information of dose and position is transmitted to the DAQ system by RS-485 interface.

PERFORMANCE

The compact ionization chambers were tested in Shanghai Advanced Proton Therapy Facility. We used proton beams with different dose rates to measure linearity of the dose monitor. The energy of the proton beam was 235MeV. The test bench is illustrated in Fig. 5. A commercial ionization chamber (TW34070, PTW, Germany) was utilized to collect delivered dose. The signal from TW34070 was digitized in UNIDOS-E (PTW, Germany), and compared with data from the dose monitor.

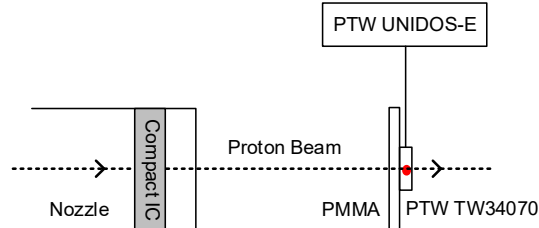

Figure 5: The test bench for the dose monitor.

The test results with minimum dose rate of 1MU/s and maximum dose rate of 10MU/s are illustrated in Fig. 6A and Fig. 6B. Nonlinearity error of the accumulated dose is less than $\pm 0.1\%$.

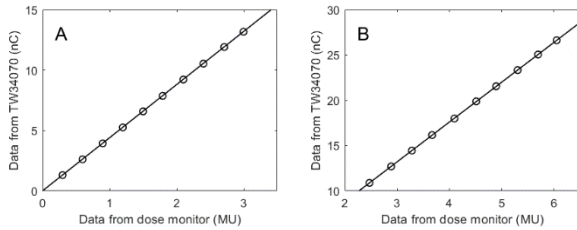

Figure 6: Linearity of spot dose. (A) Linear fitting with dose rate of 1 MU/s. (B) Linear fitting with dose rate of 10 MU/s.

We used proton beams with different energies to measure position accuracy of the position monitor. The test bench is illustrated in Fig. 7. A commercial 2D array monitor (PT Lynx, IBA, Belgium) was placed at the isocenter to receive proton images. The 2D images obtained in PT Lynx were compared with data from the position monitor.

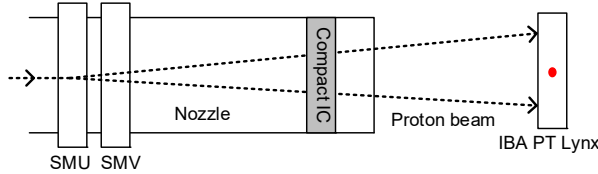

Figure 7: The test bench for the position monitor.

The spot matrices with maximum energy of 235MeV and minimum energy of 70MeV are illustrated in Fig. 8A and Fig. 8B. Data from position monitor were used to calculate the gravity center of each spot. By comparison of position data from the position monitor and PT Lynx, the position accuracy of the compact ionization chambers is less than 0.2mm.

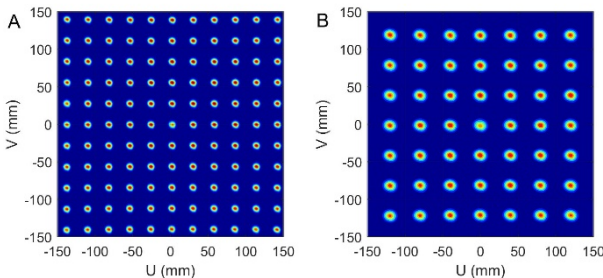

Figure 8: Spot matrices. (A) Spot matrix with energy of 235MeV. (B) Spot matrix with energy of 70MeV.

OUTLOOK

The compact ionization chambers were developed and implemented in Shanghai Advanced Proton Therapy Facility. Compared with traditional schemes, the new scheme integrated front-end electronics in the chambers, realized digitization in early stage of process and achieved modularization of dose monitor and position monitor.

In the future, we will strengthen modularization by integrating DAQ part into the chambers, as illustrated in Fig. 9. The DAQ part will utilize an FPGA chip to realize integration of dose in time domain and calculation of spot position and size. The processed information will be transmitted to treatment control system by optic fiber. Therefore, the transmission of the medical data will be much less susceptible to interference in an irradiation environment.

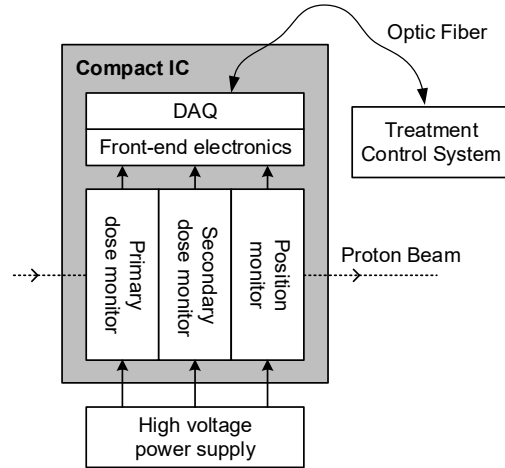

Figure 9: The new structure of the compact ionization chambers.

The working medium of the compact ionization chambers is free air. So, the humidity in treatment rooms has a great effect upon the stabilization of the output data. In the extremity of air-conditioning failure, great current beyond the range of measurement would cause irreparable damage to the front-end electronics. A semi-airtight structure will be adopted for future design, and desiccative will be allocated in the air inlets.

The new compact ionization chambers will be much more stable and easier-to-use with the above improvement. The modularized beam monitors are applicable to diversified particle therapy facilities.

REFERENCES

- [1] https://en.wikipedia.org/wiki/Particle_therapy
- [2] M. Z. Zhang et al., "Commissioning of Shanghai Advanced Proton Therapy", in *Proc. 9th Int. Particle Accelerator Conf. (IPAC'18)*, Vancouver, BC, Canada, Apr.-May 2018, pp. 1151-1154. doi:10.18429/JACoW-IPAC2018-TUPAL059
- [3] <http://erice2009.na.infn.it/TalkContributions/Flanz1.pdf>
- [4] C. H. Miao, M. Liu, C. X. Yin et al., "Precise magnetic field control of the scanning magnets for the APTRON beam delivery system", *Nucl. Sci. Tech.*, vol. 28, p. 172, 2017. doi:10.1007/s41365-017-0324-6
- [5] B. Q. Zhao, M. H. Zhao, M. Liu et al., "The front-end electronics design of dose monitors for beam delivery system of Shanghai Advanced Proton Therapy Facility", *Nucl. Sci. Tech.*, vol. 28, p. 83, 2017. doi:10.1007/s41365-017-0230-y

Content from this work may be used under the terms of the CC BY 3.0 licence (© 2019). Any distribution of this work must maintain attribution to the author(s), title of the work, publisher, and DOI