

RETRIEVING BEAM CURRENT WAVEFORMS FROM ACCT OUTPUT USING EXPERIMENTAL RESPONSE FUNCTION FOR USE IN LONG PULSE ACCELERATORS

Y. Hirata[†], J. Franco Campos, A. Kasugai, Rokkasho Fusion Institute, National Institutes for Quantum and Radiological Science and Technology, Aomori 039-3212, Japan

Abstract

Current transformers (ACCT/DCCT) are used as non-interceptive means of beam current measurement in many accelerators. In the case of long pulse to CW accelerators for fusion neutron sources such as IFMIF, A-FNS, etc., current measurement using current transformers for pulses with around 10-100 ms or longer suffer such problems as drooping and the measurement accuracy is deteriorated. So, improving the accuracy for long pulse beams is highly required. We have proposed a method for retrieving the beam currents from the ACCT output using a transfer function obtainable from simple experiments. It was confirmed from numerical calculation that beam currents longer than a second could be theoretically retrieved. The effects of associated circuits and cables such as stray capacitance, inductance and magnetic materials nearby are inherently included in the transfer function. We are working for implementing this method into FPGA. For calculation convenience, the transfer function is converted into a form of impulse response function and the convolution with the digitized ACCT output is to be carried out to retrieve the beam current. The theory, algorithm and design will be discussed.

INTRODUCTION

Current transformers (ACCT/DCCT) are used as non-interceptive means of beam current measurement in accelerators. Current measurement using current transformers (CTs) for long pulses with 10-100 ms or longer suffers such problems as droops.

In the case of long pulse to CW accelerators for fusion neutron sources such as IFMIF, A-FNS, etc., the deterioration of measurement accuracy could be crucial and improving the accuracy for long pulse beams, or at least in the gap uncovered by the ACCT and DCCT, is highly required.

Measurement errors with an ACCT for long pulses are due to the fact that this measurement is based on the current induction through transformers and is considered inevitable. Ideally the output of ACCT is supposed to be the derivative of the beam current, so the integrator at downstream will give back the beam current. In reality, however, the output signal from the ACCT is not an ideal derivative. There is influence from the cable stray impedance, capacitance, inductance, associated amplifier, etc.

The electrical circuits connected to CTs have been improved in order to reduce drooping and to obtain a waveform as close as to the original beam current waveform, but the decay time of the circuit can be extended up to as

long as 1 second or could be a little longer [1,2,3]. Moreover, there is need to reduce the influence of the magnetic materials nearby [2, 4].

In our previous study [5], a method for obtaining the beam current waveforms from the waveform of ACCT output signals have been proposed. Since the ACCT and associated electrical circuits can be considered as a linear system, there must be a unique transfer function that connects the input and the output. This transfer function and the backward transfer function can be obtained numerically from simple experiments. The conversion from the output waveform to the input waveform is "ideal" since it is free from restrictions of real circuits.

This method has several advantages: (1) no detail information about the ACCT and the electronics is necessary; (2) the transfer function is easy to obtain from simple experiments with a function generator and an oscilloscope other than the ACCT and an amplifier; (3) effects of stray capacitance, inductance and magnetic materials nearby are inherently reflected in the transfer function; (4) the use of FFT speeds up the calculation for obtaining the transfer function.

On the other hand, it does not allow a continuous or sequential beam retrieving since the retrieval can be done only over a certain time period which is the time window for FFT. Sequential retrieval is more convenient to be implemented with FPGA and for use in practical occasions.

In this paper, the viability of sequential retrieval of beam current waveform from the ACCT output is examined. We reformulated the theory in [5] into a convolutional form using response functions. An algorithm for FPGA was clarified and a simple program was made to check the validity of the algorithm.

It is said to be typical that a response function obtained from DFT (digital Fourier transformation) suffers some ghost signal problems coming from its periodic nature. A method for reducing this kind of ghost signals has also been examined.

This paper is organized in the following manner. Theory and an algorithm to be implemented will be given in the next chapter, followed by the check of its validity using data obtained in simple tests. Conclusions will be offered in the last chapter.

THEORY

A method presented in [5] for retrieving a beam waveform function from the observed ACCT output using a transfer function is a signal processing effective for the

periodic beam pulses and the retrieval needs to be performed every pulse period, not real time or sequential. Sequential retrieval is more convenient in practical use. In this report, converting the transfer function into a response (or filter) function to be used in convolution and the viability of real time or sequential retrieving is examined.

We assume that an ACCT and an associated amplifier can be considered as a linear system. If the current input into the ACCT, the output of ACCT and the response function are written as $f(t)$, $h(t)$ and $g(t)$, respectively, the ACCT output can be written as

$$h(t) = \int_{-\infty}^{\infty} f(\tau)g(t - \tau)d\tau. \quad (1)$$

Fourier transforming both sides of Eq. (1) will lead to

$$\tilde{h}(\omega) = \tilde{f}(\omega)\tilde{g}(\omega). \quad (2)$$

Here $\tilde{g}(\omega)$ is the transfer function. Once $\tilde{g}(\omega)$ is found, the output waveform can be calculated from the input waveform.

For calculation using FFT, the discrete time and frequency are defined as follows:

$$t_k = \frac{T}{N}k \quad (k = 0, 1, \dots, N), \quad (3)$$

and

$$\omega_k = \frac{2\pi}{T}k \quad (k = 0, 1, \dots, N). \quad (4)$$

T is the time window for FFT. The transfer function from input to output, $\tilde{g}(\omega_k)$, can be calculated using FFT values of $\tilde{f}(\omega_k)$ and $\tilde{h}(\omega_k)$ as

$$\tilde{g}(\omega_k) = \frac{\tilde{h}(\omega_k)}{\tilde{f}(\omega_k)}. \quad (5)$$

Inversely, the FFT values of the input, $\tilde{f}(\omega_k)$, can be calculated from those of the observed output, $\tilde{h}(\omega_k)$.

$$\tilde{f}(\omega_k) = \frac{\tilde{h}(\omega_k)}{\tilde{g}(\omega_k)} \equiv \tilde{p}(\omega_k)\tilde{h}(\omega_k). \quad (6)$$

$\tilde{p}(\omega_k)$ is the transfer function from the output signal to the input defined as

$$\tilde{p}(\omega_k) = \frac{\tilde{f}(\omega_k)}{\tilde{g}(\omega_k)}. \quad (7)$$

Reference [5] has reported that the forward and backward transfer functions, $\tilde{g}(\omega_k)$ and $\tilde{p}(\omega_k)$, are uniquely obtainable from simple experiments using square waves and that the conversion between ACCT input and output signals is possible.

Moreover, by inversely Fourier transforming $\tilde{p}(\omega_k)$, the response (or filter) function, $p(t)$, is obtained that can convert the observed ACCT output signals back to the input waveforms as

$$f(t) = \int_{-\infty}^{\infty} h(\tau)p(t - \tau)d\tau. \quad (8)$$

Eq. (8) is a convolutional form of $h(t)$ and $p(t)$, integrating RHS of Eq. (8) from the beginning, sequential transform from the observed ACCT output to the input can be calculated. For those response functions calculated by FFT, the input waveform, $f(t_k)$, is calculated by

$$f(t_k) = \sum_{i=0}^{k-1} h(\tau_i)p(t_k - \tau_i), \quad \tau_i = t_i \quad (9)$$

In such cases as signal delays due to long cable length and slow transaction time of associated circuits, the starting time of the input and output signals is different. But as long as the starting time of the signal data acquisition is the same, the response function should include this delay. Simply calculating Eq. (9) brings the input waveform with signal delay even if there is any.

It should be noted that these transfer and response functions in Eq. (9) are obtained using FFT and, so, should have a periodic nature. Therefore, by periodically shifting the time for these functions, only delay or advance of the transacted function in time can be changed, still preserving the viability of retrieval.

RETRIEVAL OF ACCT INPUT WAVEFORM FOR TEST PULSES

Calculation of Eq. (9) is schematized in Fig. 1. The observed signal (ACCT output), $h(t)$, is digitized by an ADC and input to the FPGA. The data is shifted in the registers of the FPGA at the same timing as the ADC. On the other hand, the response function experimentally obtained is also stored in the register. The transaction in Fig. 1 is summarized as follows. At the timing of ADC of the observed signal, current and past values of the observed signal are multiplied by those of the response function and summed. The final values are output as the retrieved function. Though some delay due to ACCT, cables, electrical circuits, FPGA transaction, etc., will exist, the retrieval is carried out sequentially.

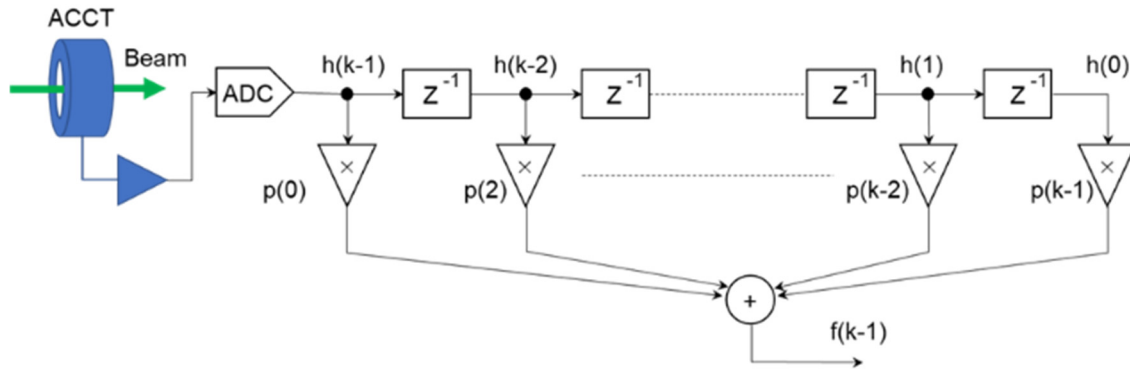

Figure 1: Algorithm of convolutional calculation converting the ACCT output to ACCT input.

Square pulses from a function generator were used to obtain the response function. The termination to the ACCT output was 150 ohm and no amplifier was used. It is assumed that these transactions will be implemented in an FPGA. Parameters for FFT and transactions of FPGA are listed in Table 1.

Table 1: Parameters in FFT

FFT time window	0.131072 [sec]
Number of divisions	$131072 = 2^{17}$ [points]
Time resolution	1 [μs]

Figure 2 shows the input and output of the ACCT with a square pulse length of 10 ms. No integrator or other circuit but a 150-ohm resistor was connected to the output of the ACCT and the output signal is directly observed with an oscilloscope. The sampling frequency was 10MHz and a moving average method over 128 points was applied to reduce the noise.

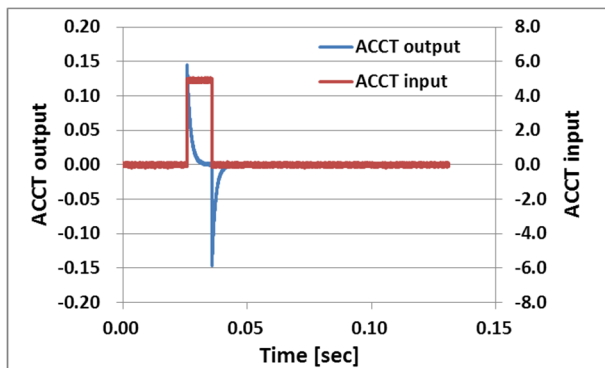

Figure 2: ACCT input and output (10 ms pulse).

The ACCT output in Fig. 5, the decay time is as long as 5 ms (or a bit shorter). So, the test pulses to achieve the response function should cover this transient variation to correctly define the response of the ACCT system. Therefore, 10-ms and 50-ms pulses were chosen as the test pulses. In addition, square-shaped pulses were chosen since they contain the widest spectrum in frequency. The two response functions numerically obtained from the two

test pulses independently were averaged to get the final response function. The final response function so obtained is shown in Fig. 3.

The final response function from the ACCT output to input obtained is shown in Fig. 4. The response function was obtained using FFT so it has a periodic nature. The peak observed in the last moment of the waveform is equivalent to the peak just before the start of the signal ($t < 0$), which can be interpreted as the recovery of the signal delay due to transmission through the ACCT and its associated circuit.

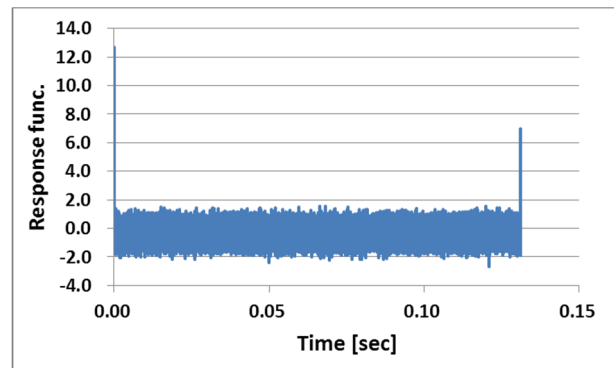

Figure 3: Response function from ACCT output to input.

If we use the response function in Fig. 4, the retrieved wave should have two peaks due to the separated peaks at the beginning and the end of the time window. Taking advantage of the periodicity of the response function, the response function was localized so that peaks were gathered by shifting timewise the response function by half of its period. The resultant response function is shown in Fig. 6. Major part of the retrieved signals will appear at about 0.06 sec.

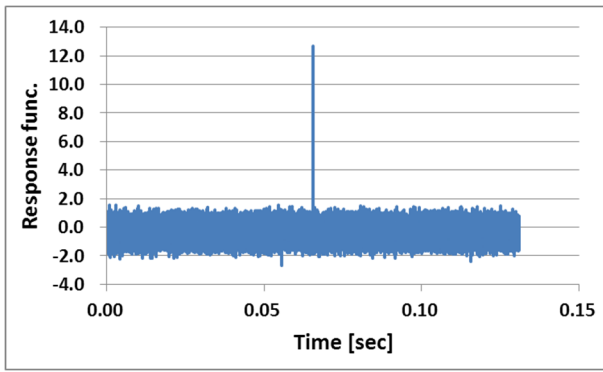

Figure 4: Centralized response function.

Applying this centralized response function, the retrieval was attempted. We made a small program in FORTRAN and simulated the retrieval. The time span of simulation was twice as long as the FFT time window in order to observe the effects of periodicity. The resultant retrieved signal is shown in Fig. 7. The major part—the current waveform—can be retrieved, but at the same time big ghosts are observed. This implies that the meaningful part of the response function is not fully localized but distributed.

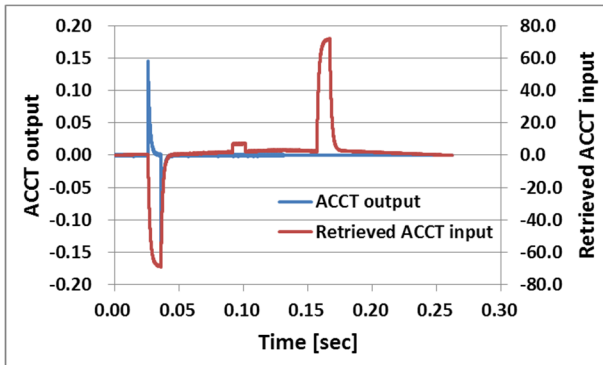

Figure 5: Retrieved ACCT input waveform using response function in Figure 4.

At the center of the retrieved waveform, a square pulse with the same height as the ACCT input (5 V) is retrieved but ghost signals appear. To remove this, a window function is attempted. The response function with the window function considered, $p'(t)$, is given by:

$$p'(t) \equiv w(t)p'(t) \quad (10)$$

$$w(t) \equiv \begin{cases} 1 - \left(\frac{t - 0.065536}{T_w} \right)^8 & \text{for } \left| \frac{t - 0.065536}{T_w} \right| < 1, \text{ and} \\ 0 & \text{for } \left| \frac{t - 0.065536}{T_w} \right| \geq 1 \end{cases} \quad (11)$$

For trial, $T_w = 0.04$ [sec] was chosen and the same simulation was carried out. Figure 6 shows the window and response functions; Figure 7 shows the retrieved ACCT input. It is observed that the ghosts have not been removed. The width of the window function has been

changed to various values down to 2.5 ms, but similar ghosts appeared. It can be inferred that there is meaningful information distributed over the response function, even in the random-noise-like signals.

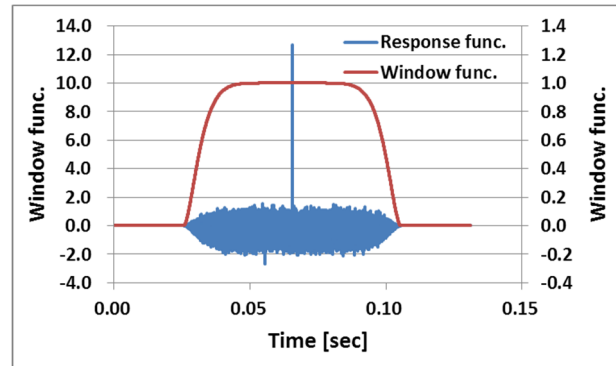

Figure 6: Response function with a window function of $T_w = 0.04$ [sec].

As described before, the ACCT works based on induction, so the transmitting signal contains some waveform reflecting the derivative transaction. So the response function directly converting the ACCT output to the input, like Fig. 4, should have some integral transaction. Since the response function for the pure integration should be the Heaviside step function, it is not localized but should be distributed or broad. It is understandable that those random-looking peaks in the response function have some meaning as a total.

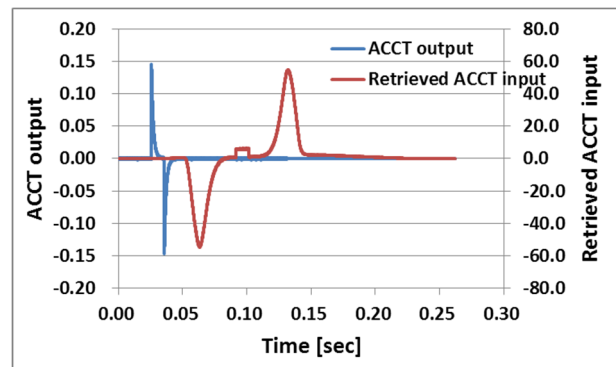

Figure 7: Retrieved ACCT input waveform using response function with a window function shown in Fig. 6.

Next, we consider separating the retrieval in two steps: a step for converting the ACCT output into the pure derivative of the input waveform and a step for applying pure integration. By excluding the integral process, which is supposed to contribute to the broadness in the response function, it is likely that this response function becomes localized.

In this new process, the derivative of the ACCT input will be calculated using the response function.

$$\frac{df(t)}{dt} = \int_{-\infty}^{\infty} h(\tau)p'(t - \tau)d\tau. \quad (12)$$

Applying the response function for integral, i.e. a Heaviside step function, to the derivative (Eq. (12)) afterwards, the ACCT input waveform will be obtained.

In the same manner as previously, square test pulses with lengths of 10 ms and 50 ms were used to calculate the averaged response function, followed by applying the Heaviside step function to retrieve the ACCT input. Here a window function with $T_w = 0.0025$ [sec] was also applied.

Since the region outside the window function does not have meaning, so eliminating the outside zero region is acceptable. This means that the response function can be shorter, accordingly the delay time for retrieval can be shorter as well. The new response function and the window will be like those in Fig. 8. Here the length of the response function is 8.192 ms (8,192 data points) compared with the original divisions of 131.072 ms. The time needed to carry out the convolution will be 16 times shorter.

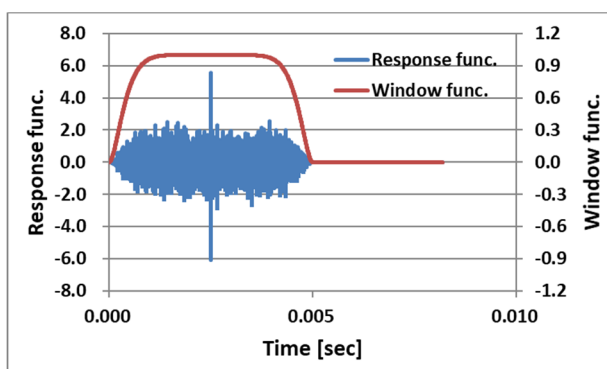

Figure 8: Window and shortened response functions.

Using this short response function, ACCT input square pulses with lengths of 1 ms, 5 ms, 10 ms and 50 ms were retrieved. The retrieved signals are shown in Fig. 9, Fig. 10, Fig. 11 and Fig.12, respectively. There are some noisy signals observed but those square input pulses were correctly recovered without ghosts. The delay time of retrieval is 2.5 ms as expected.

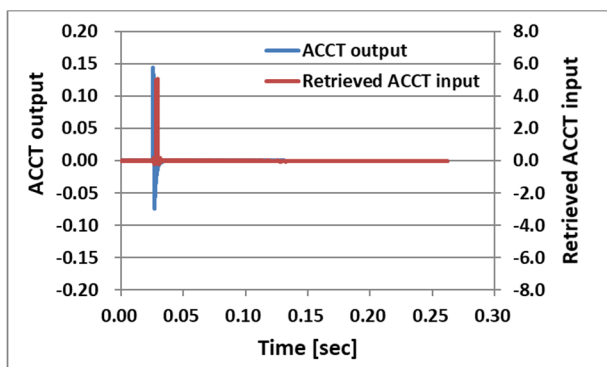

Figure 9: ACCT input waveform retrieved using response function in Figure 8 (for 1-ms square test pulse).

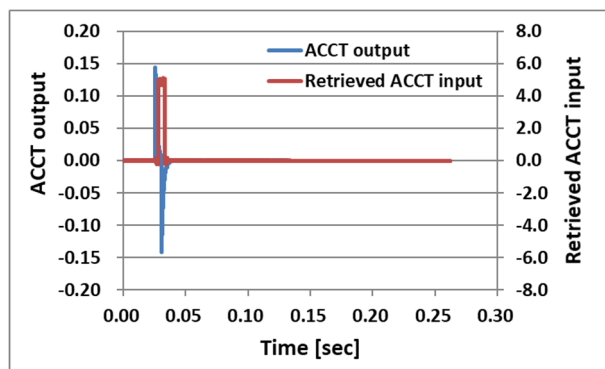

Figure 10: ACCT input waveform retrieved using response function in Figure 8 (for 5-ms square test pulse).

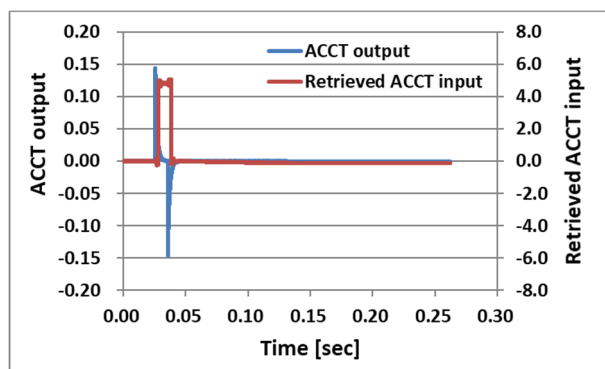

Figure 11: ACCT input waveform retrieved using response function in Figure 8 (for 10-ms square test pulse).

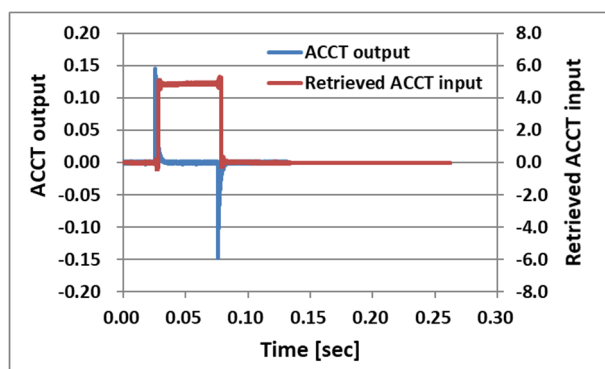

Figure 12: ACCT input waveform retrieved using response function in Figure 8 (for 50-ms square test pulse).

CONCLUSIONS

In order to reduce errors from drooping, etc., in the non-interceptive current measurement using current transformers for pulses with 10-100 ms or longer, a method for retrieving the beam currents from the ACCT output has been investigated. Based on our previous research using a transfer function, response functions were used to achieve sequential retrieval as well as to implement this method in FPGA. The conclusions are as follows:

Content from this work may be used under the terms of the CC BY 3.0 licence (© 2019). Any distribution of this work must maintain attribution to the author(s), title of the work, publisher, and DOI

- (1) A theory for sequential retrieval of the ACCT input from output using a response function has been formulated. Based on this, an algorithm for convolutional calculation in FPGA has been proposed;
- (2) For test pulses, the response function for directly converting the ACCT output into ACCT input was obtained. Major part of the ACCT input could be retrieved, but ghost signals appeared. This is considered due to the periodic and integral nature of this process;
- (3) The ghost signals have been removed successfully by the following two attempts:
 - A) Separate the process in two steps: to seek a response function to obtain the derivative of the ACCT input and to apply a Heaviside step function afterwards;
 - B) Introduce a window function with a time span of 0.0025 [sec] to reduce the ghosts due to the rise of the ACCT output signals.
- (4) The time span of the window function could be reduced as short as 2.5 ms. Accordingly, the time delay for retrieval can be as short as 0.0025 [sec].

REFERENCES

- [1] S. Leloir, et al., "Measurement and control of the beam intensity for the SPIRAL2 accelerator", in *Proc. IBIC2013*, Oxford, UK, 2013, paper WEPF33, pp. 900-902.
- [2] U. Raich, "Beam Diagnostics," text of CERN Accelerator School 2005.
- [3] M. C. Bastos, "High Precision Current Measurement for Power Converters," CAS-CERN Accelerator School: Power Converters, CERN-2015-003, CERN, 2015.
- [4] H. Bayle, O. Delferriere, R. Gobin, F Har-rault, J. Marroncle, F. Senée, C. Simon, O. Tuske, "Effective shielding to measure beam current from an ion source," *Rev. Sci. Inst.*, vol. 85, No. 2, p. A713, 2014.
doi:10.1063/1.4829736
- [5] Y. Hirata, et al., "Improving accuracy of noninterceptive current measurement for use in IFMIF/EVEDA accelerator", *IEEE Trans. Plasma Sci.*, vol. 46, pp. 2272-2276, 2018.