

## INTEGRATED DESIGN OF LASER SYSTEMS FOR A FEL USER FACILITY

M.B Danailov, Sincrotrone, Trieste, 34012 Trieste, Italy,

F. Ö. Ilday and F. X. Kaertner, MIT, Cambridge, MA, USA.

### Abstract

The paper presents a general layout and main technical parameters of the laser systems for the FERMI FEL. An important point in the proposed layout for system integration is the possibility to replace the mode-locked seed oscillators by Er-doped fiber amplifiers at 1560 nm, followed by harmonic conversion. The required seed pulse parameters at different locations are specified and the feasibility of this approach is discussed.

### INTRODUCTION

Laser systems will undoubtedly be one of the key factors determining the performance of VUV and X-ray FELs. In particular, harmonic generation scheme based FELs require at least three mutually synchronized solid-state laser systems: photoinjector laser, seeding laser, end station lasers. In addition, a laser heater is also included in recent FEL designs. It is therefore very important to consider the possibility of integrating these systems to a maximum possible degree. In this paper we consider a promising approach to the integration of the above specified laser systems for the FERMI@ELETTRA FEL, based on the distribution of a fiber laser generated seed signal at 1550 nm. This signal, after further amplification and frequency doubling, is used as a seed for Ti:Sapphire amplifiers at the different locations. The paper presents a general layout of the system, the main pulse parameters (i.e. pulse energy and duration) needed in different parts of the system, and discusses possible technical solutions.

### GENERAL LAYOUT

The figure shows schematically the main FERMI FEL units and the positions of the main laser systems. As mentioned above, our concept is based on a single optical master oscillator. The principal point of the approach presented here is to attempt replacement of the seeding mode-locked Ti:Sapphire oscillators of all laser units by a single one, called here ultrafast optical master oscillator (UOMO). In addition to providing optical seed, the latter will also provide the clock for RF plants of the facility.

The replacement of 4 or 5 separated mode-locked Ti:Sapphire oscillators by a single mode-locked fiber laser has obvious potential advantages:

- a. Reliability
- b. Lower jitter (no separate synchronization needed).
- c. Reduced cost.

However, certain issues have to be addressed in order to put this idea in practice:

- a. Providing enough energy for seeding Ti:sapphire based regenerative amplifier at 780 nm requires high peak powers, so pulse stretching, amplification and compression should be carefully designed to avoid pulse deterioration due to nonlinear effects in the fibres.
- b. For the same reason, the system of harmonic conversion from 1560 to 780 nm has to be optimised for high efficiency and low pulse distortion.
- c. Different seed pulse durations might be needed in the different laser systems.

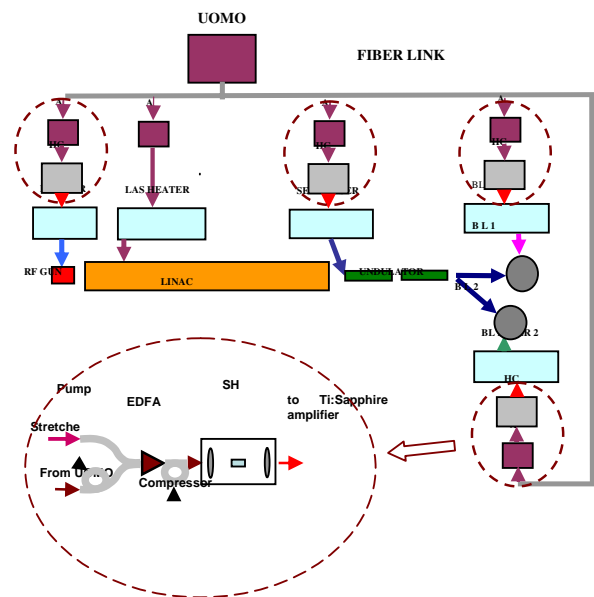

Figure 1. Layout of the main laser systems: Uomo – ultrafast optical master oscillator; A, EDFA – fiber amplifiers; HC –harmonic conversion; BL1,2 – beamlines.

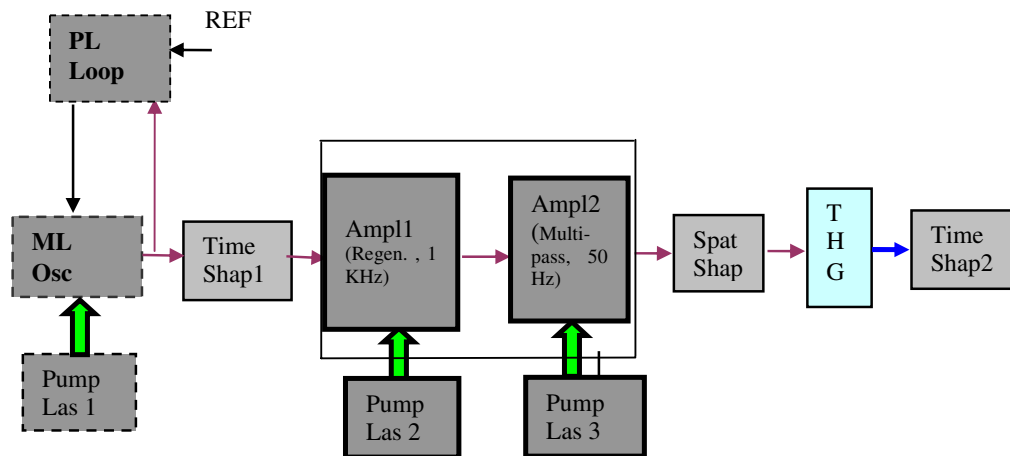

Figure 2. Bloc-scheme of the PI laser system proposed for FERMI.

### PHOTOINJECTOR LASER

The photoinjector (PI) laser specs have been extensively discussed in the community in the last several years. When a Copper photocathode is to be used, there seems to be a convergence on the following parameters:

Pulse duration: 3-6 ps (FWHM), shape: flat-top  
 Rise-time: 0.5-1 ps (10-90%)  
 Spatial profile: top-hat, ~ 1 mm (up to 2 mm)  
 UV wavelength: 260-267 nm  
 UV (on the photocathode): ~0.4 mJ  
 Timing stability with respect to RF: < 0.3 ps RMS  
 Energy stability (UV): < 4% RMS

Given the required rise time and pulse energy, at present the only commercial solution that can safely meet the specifications is a Ti:Sapphire based regenerative-multipass amplifier combination delivering above 15 mJ pulse energy around 780 nm. The design we propose has the following new features:

A. Replacement of the mode-locked Ti:Sapphire oscillator, pumped by a CW green laser (dashed line boxes in Fig.2) by an amplified and subsequently frequency doubled fiber delivered signal generated by UOMO. The main challenge would be to reach an energy of at least 0.4 nJ, keeping the pulse duration in the 120 fs range. This (conservative) value takes into account a set of measurements we have done recently in the laser lab, where the seeding light of a commercial regenerative amplifier (LEGEND USP HE, Coherent) has been varied. We observed that the amplifier performance in terms of stability and output power remained unchanged down to 0.2 nJ seed pulse energy. Taking into account also the losses for pulse shaping before the amplifier (TimeShap1 in Fig. 2) one arrives at 0.4 nJ minimum seed energy.

B. As it can be seen from Fig. 2, we intend to divide the pulse shaping process in two stages. The above mentioned shaping prior to amplification and frequency conversion will be performed by using a programmable acousto-optic

dispersive filter (DAZZLER [1]). The pulse shaping function of the DAZZLER will be mostly to introduce small corrections and to allow dynamic changes of the final pulse shape, while the final pulse duration will be determined by a 4-f system type [2, 3] shaper in the UV (Time Shap 2 on Fig. 2). The exact configuration and operation of the temporal shaping system is beyond the scope of the present paper, they are mentioned here inasmuch the use of DAZZLER is stated to require at least 8-10 nm of bandwidth for providing the needed temporal resolution. Therefore, if a fiber oscillator is used for seeding, it should provide sufficient bandwidth at 1560 nm.

C. A spatial shaping unit (Spat Shap) is introduced before the frequency conversion for converting the Gaussian-like amplifier output into a flat-top profile. Even if such a configuration may seem to decrease the conversion efficiency at first glance due to lowering the peak power, in our conditions where peak power is in excess we expect it would allow better overall performance of the setup.

### SEED LASER SYSTEM

The main requirement for this laser source, as defined in the present stage of the machine design, is to deliver sufficiently high peak power (~100 MW), at wavelengths tunable in the range 240-360 nm. An additional complication arises from the required two different pulse durations, i.e. the system should be able to switch between a short (~200 fs) and a long (~1 ps) pulse mode of operation, without deviating from close to the transform-limit.

Such a broad UV tuning can only be met at present by using parametric amplification (PA) in the visible or near infrared with consecutive harmonic generation. We consider two feasible solutions:

### TOPAS/NOPA System

Parametric amplifier pumped by an amplified Ti:Sapphire laser system (or its second harmonic). The seed laser then will consist of:

1. Pump laser: a commercial Ti:Sapphire laser system 10-15 mJ, 200 fs – 1 ps.
2. Parametric amplifier,
  - a. is a visible non-collinear parametric amplifier (NOPA). The output of the NOPA is frequency doubled to produce 240 -360 nm light
  - b. Laser 1 pumps directly an infrared traveling wave parametric amplifier (TOPAS), signal and idler pulses of the TOPAS are then frequency mixed with the fundamental and frequency doubled to cover the 240-360 nm
  - c. Laser 1 is frequency doubled (400 nm) and pumps a visible TOPAS, its signal wave is frequency doubled to obtain 240-360 nm light.

Also in the case the pump laser can be seeded by the method we propose. Parameters of the seed in this case are similar, with the main difference that two different pulse durations are needed. Analysing the scheme we came to the conclusion that two separate EDFA amplifiers will have to be used, followed by two nonlinear crystals of different length. Simulations using SNLO showed that the use of periodically poled LinBO<sub>3</sub> crystals should allow better than 25% conversion efficiency in both cases if length and focusing are optimised. In the long pulse case a bandpass filter can be used to narrow the bandwidth before amplification.

### Cavity-Enhanced Parametric Amplification

A novel method for the generation of high-energy ultrashort optical pulses is under development at the MIT Optics and Quantum Electronics Group [4]. Through the combination of parametric amplification [5] and enhancement cavities [6,7], this method opens a route to generate ultrashort pulses at unprecedented average power levels through the use of lower-energy, higher average-power pump sources and energy storage in the enhancement cavity.

Parametric amplification can be thought of as the utilization of an “engineered” gain medium, where the traditional energy states of an amplifying medium are replaced by virtual states arising from the coupling of the pump, signal and idler beams through nonlinear polarization. As such, there is no storage of the pump light, necessitating synchronous pumping. Ideally, parametric amplification can be scaled up to arbitrarily large pulse energies by increasing the beam sizes. The lack of storage of pump light eases thermal and material damage limitations. The biggest difficulty is perhaps the need for a high-energy pump source with picosecond pulses.

Our approach can be regarded as a conceptual combination of the parametric amplification and enhancement cavity techniques (Figure 3): The pump

beam is coherently enhanced in a high-finesse external cavity, which contains a nonlinear crystal phase-matched for parametric amplification of a signal pulse and is transparent to the signal wavelength. The stretched signal pulses are synchronized and time-gated to overlap spatially and temporally with the pump beam once the cavity is loaded, undergoing parametric amplification. This way, signal pulses with pulse durations anywhere from few fs to few ps can be amplified. The pump energy is extracted out of the cavity by conversion to the signal wavelength, for which the cavity mirrors are chosen to be highly transmissive. Thus, we are extending the analogy of parametric amplification to regular amplification one step further: The cavity assumes the role of pump light storage, with the product of the cavity roundtrip time and the finesse corresponding to the gain relaxation time.

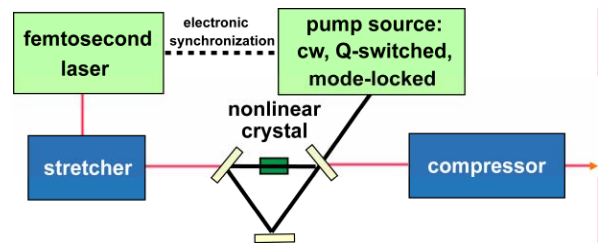

Figure 3. Schematic of the cavity-enhanced parametric amplification approach.

Several major advantages can be identified. The pump light itself can be in the picosecond range or even longer, thus dispersion ceases to be a limitation to the enhancement cavity. With increasing finesse of the cavity, the pump source has only to provide lower peak powers, opening up the use of laser sources, which excel in high average power, but are limited in peak power, such as fiber amplifiers, where ~1 kW of average power has been demonstrated. Importantly, the high-finesse cavity will act as an excellent spatial filter for the pump beam, ensuring a high beam quality, at the expense of some small amount of power loss. This point is crucial for maintaining a high beam quality.

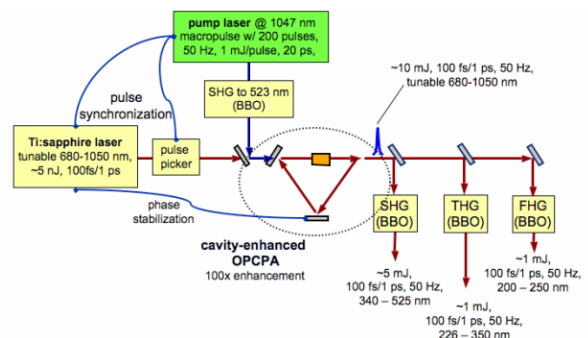

Figure 4. Schematic of the proposed implementation of the PI laser, based on the cavity-enhanced parametric amplification approach.

The practical implementation is envisioned to be as follows (Figure 4). The signal pulses can be provided by a commercial Ti:sapphire laser, which is widely tunable over the wavelength range of 680-1050 nm, with either ~100 fs or ~1 ps pulses. The pump system can consist of a high-energy fiber amplifier (home-built, up to 0.1 mJ of individual pulse energy), followed by a multi-pass Nd:YLF gain modules (up to 1 mJ/pulse, also commercially available). The important point is that a group of 200 pulses, constituting a macropulse will have to be amplified, to fill in the enhancement cavity (with an enhancement factor of ~100). As such, regenerative amplifiers are not practical. Preliminary amplification stages, pumped by 1-mJ pulse (single-pass, no cavity) amplifies the signal pulses to ~0.1 mJ. Accounting for the loading losses, a giant pulse with 100 mJ of energy can be stored in the enhancement cavity and used to amplify the signal pulses to ~10 mJ. Upon nonlinear frequency-conversion, the wavelength ranges of 340-525 nm, 226-350 nm, and 200-250 nm will be covered by second, third, and fourth harmonic generation, respectively. The expected pulse energy is at least 1 mJ (>5 mJ for the second-harmonic).

In summary, we view this approach as an attractive practical route in development to easily meet and even significantly exceed the demands on pulse energy, duration and repetition rate of the PI laser. In order to reach even higher energies, nonlinearity management in the enhancement cavity can be utilized.

### DIRECT SEEDING WITH THE OPTICAL SYNCHRONIZATION PULSES

There is an attractive possibility of creating a more integrated and low-jitter laser system: The optical synchronization system proposed by MIT is based on the distribution of sub-picosecond optical pulses around 1550 nm in optical fiber. In accelerators where such a system is adopted for timing synchronization, the very same pulses can be amplified, shaped and frequency-doubled to 775 nm to directly seed Ti:sapphire amplifiers, or in some cases directly used to fulfill functions, such as the heater laser. Such an approach significantly simplifies the laser architecture, reduces cost (replacing a Ti:sapphire oscillator) and perhaps most importantly provides automatic synchronization.

Seeding solid-state amplifiers with frequency-doubled Er-fiber lasers is proven concept, and forms the basis of the regenerative amplifier product of at least one company. In the present case, pulse shaping, as well as amplification will be necessary, given that the synchronization pulses will be longer and weaker than the optimum.

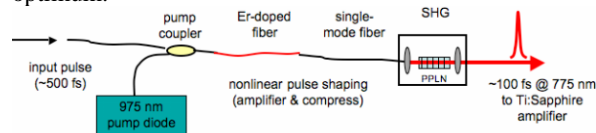

Figure 5. Schematic of direct seeding of Ti:sapphire amplifiers by amplified, shaped, and frequency-doubled pulses derived directly from the optical synchronization system.

Amplification of 1550 nm pulses up to several nJ in an Er-doped fiber amplifier, along with pulse shaping to broaden the bandwidth is feasible, either in the soliton or the similariton modes of operation of the fiber amplifier. Further investigations are necessary to carefully determine the effects of pulse shaping and amplification on the timing jitter, but initial results indicate that no significant amplitude or phase noise is added with proper design of the fiber amplifier [8].

### CONCLUSION

An approach for the integration of the main laser systems which will be included in the FERMI@ELETTRA FEL laser has been proposed. We believe this approach give important advantages both from performance and maintenance point of view and should be further investigated and put into practice in future FEL facilities.

### REFERENCES

- [1] P.Tournois, "Acousto-optic programmable dispersive filter for adaptative compensation of group delay time dispersion in laser systems", *Opt. Comm.* **140**, 245, (1997)
- [2] A.M.Weiner, J.P.Heritage, E.M.Kirschner "High-resolution femtosecond pulse shaping," , *JOSA B* **5** (1988), 1563
- [3] M.B.Danailov and I.P.Christov , "Time-space shaping of light pulses by Fourier optical processing " , *J.Mod.Opt B* **5** (1989), 725
- [4] F. Ö. Ilday, and F. X. Kaertner, "Cavity-enhanced optical parametric chirped-pulse amplification with nonlinearity management," submitted to *Optics Letters*, and references therein.
- [5] A. Dubietis, G. Jonusauskas, A. Piskarskas, "Powerful femtosecond pulse generation by chirped and stretched pulse parametric amplification in BBO crystal," *Opt. Commun.* **88**, 433-440 (1992).
- [6] B. Couillaud, T. W. Hansch, and S. G. Maclean, "High-power cw sum-frequency generation near 243 nm using 2 intersecting enhancement cavities," *Opt. Commun.* **50**, 127-129 (1984).
- [7] R. Jones, and J. Ye, "Femtosecond pulse amplification by coherent addition in a passive optical cavity," *Opt. Lett.* **27**, 1848-1850 (2002).
- [8] F. Ö. Ilday, *et. al.*, "Low-noise, high-energy, single-mode, femtosecond fiber laser system," proceedings of CLEO, Baltimore, MD, May 2005.