

## MICROPHONICS MEASUREMENTS AT ELBE

G. Staats, A. Buechner, H. Buettig, F. Gabriel, P. Michel, FZD, Dresden, Germany

### Abstract

After a short introduction into the RF low level system, results from microphonics measurements at ELBE are presented. In detail the following measurements are done: measurement of microphonics by low frequency phase controller signal; measurement of microphonics by resonance monitor independent from phase controller; measurement of mechanical cavity resonances by Lorentz-Force excitation of mechanical cavity resonances (amplitude modulation of cavity rf signal); measurement of body sound by geophone for determination of microphonics sources. A first measurement result shows a strong dependency of microphonics on the field gradient due to the higher load of the cryogenic system at higher gradients, especially for gradients over 8MV/m. Furthermore it has been found that the installed cryostat modules, each with two cavities, are very different in microphonics properties but the cavities in each of the modules are very similar and strongly coupled. A first explanation for this behavior could be mechanical differences in the modules and different sources of body sound. Further investigations are in progress. In conclusion it has been shown that any mechanical resonances of Tesla cell modules in the frequency range of about 10-100Hz should be strongly avoided by construction or if this is not possible active systems should be used for microphonics compensation.

### PRELIMINARY

The purpose of this paper is to characterize the microphonic properties of the superconducting cavities used at ELBE, shown in Figure 1. The ELBE accelerator use two cryogenic modules each of which contains two superconducting 9-cell cavities (see Aune *et. al* [1]). At maximum each cavity is capable of accelerating the electron beam by 10MeV.

Excitation of mechanical resonances of the cavities leads to a variation of center frequency and in connection with the high electric quality factor to a strong amplitude modulation of the accelerator gradient and therefore of the energy of the beam. The sensitivity of a cavity to this effect depends on the quality factor. For the cavities used at ELBE the effect is not critical due to the high bandwidth of 114Hz for the cavities. At future ERL (Energy Recovery LINACS) however, cavities with much smaller bandwidth will be used and therefore microphonics have a major influence. One of the two cryogenic modules used at ELBE is shown at the bottom in Figure 2. Also visible is the liquid Helium transfer line with the connection for the future SRF-gun. The inner construction of both modules at ELBE

is identical. Figure 3 shows a cut of the modules.

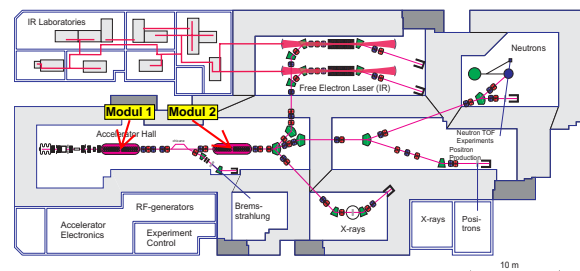

Figure 1: Radiation Source ELBE - 40 MeV, 1mA CW LINAC, Location of Cryogenic Modules.



Figure 2: First of the two cryogenic modules at ELBE.

### INTRODUCTION

Microphonics measurements at the ELBE accelerator were already made in 2002 and published by Buechner *et al* [3]. The widespread use of the Rossendorf accelerator module which is manufactured in license by ACCEL, and the recent development of energy recovery linacs, created new interest in microphonics measurements. With the further completion of the ELBE accelerator significant changes were made. In 2002 only one cryomodule with 2 cavities was in operation. The measurements in 2002 were done with the second cavity. Now we have done qualitative measurements for all 4 cavities.



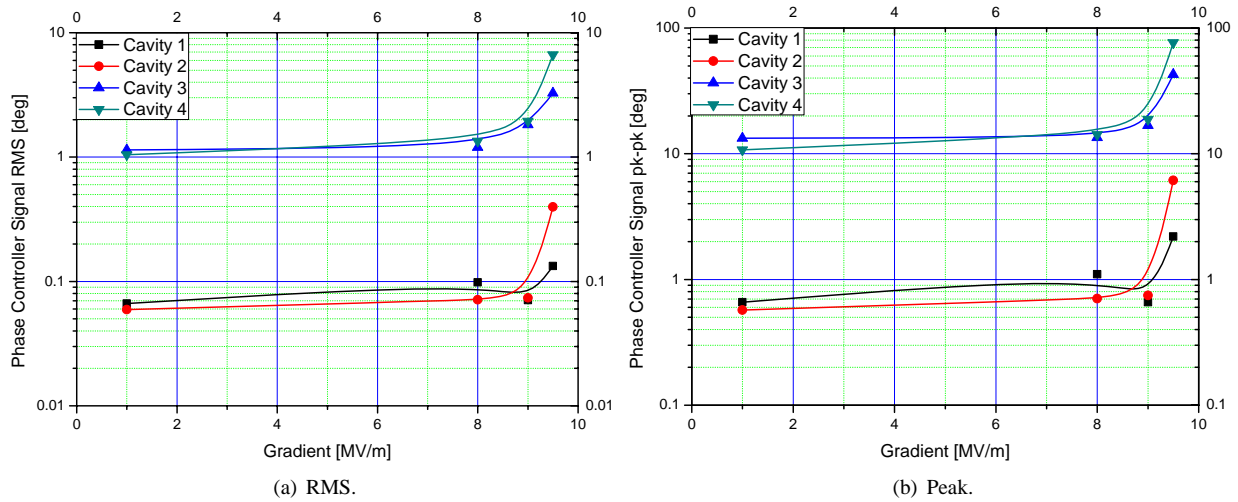

Figure 6: Variation of RMS- and Peak-values of phase controller signal with the gradient for all cavities.

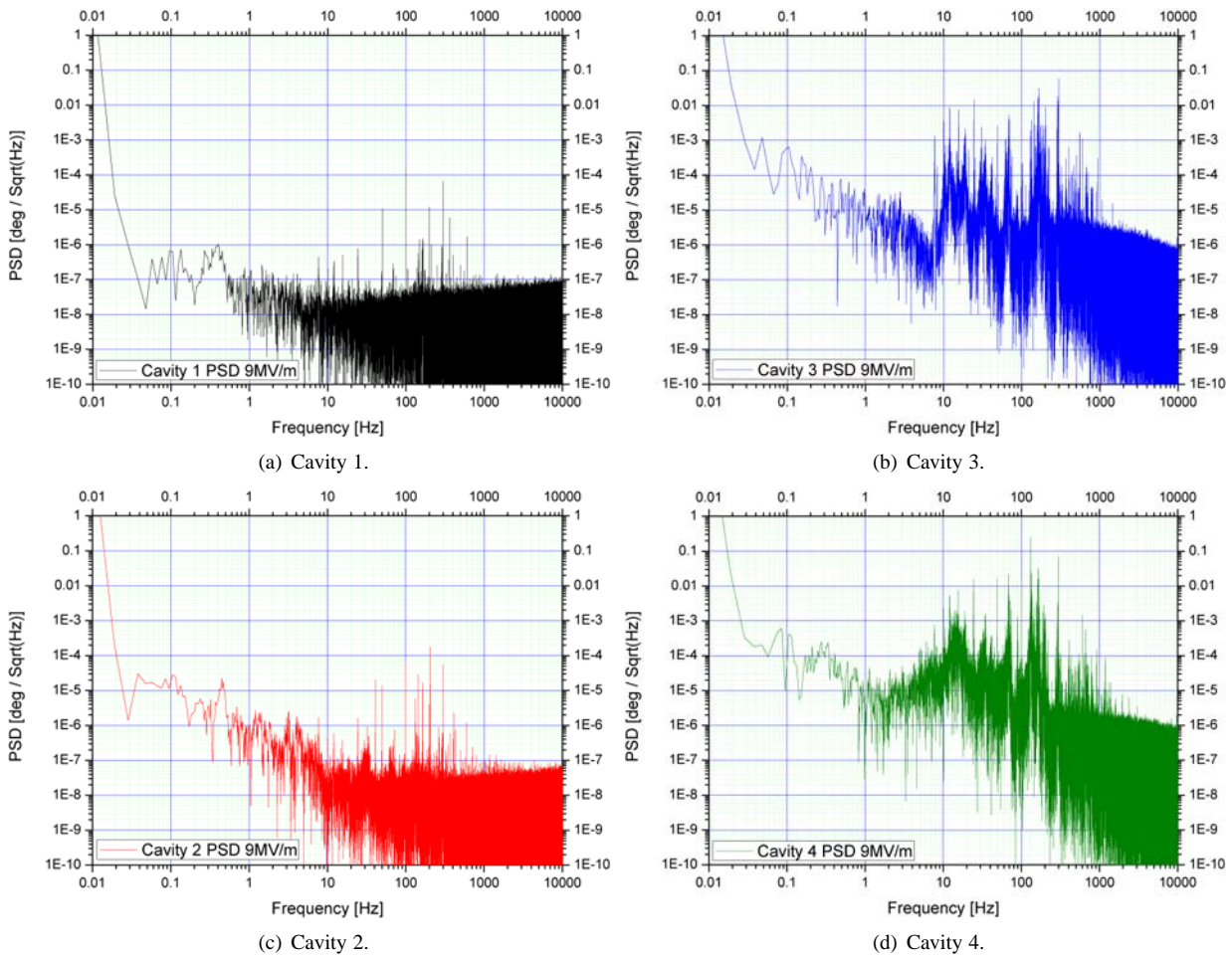

Figure 7: Variation of power spectral density of phase controller signal for cavities 1 to 4 at 9MV/m gradient.

the cavities, as shown in Figure 6. The measurement results agree well with the older data from Buechner *et. al.* [3].

The already-known difference in microphonics excitation between the two modules has been found also in these

measurements—the microphonics of module 1 with cavity 1 and 2 are much lower than the microphonics of module 2 with cavity 3 and 4. This can be also seen in Figure 7.

By peak search the resonances in Table 1 are identified. It has been found that all cavities have very similar reso-

Number	Cavity 1	Cavity 2	Cavity 3	Cavity 4
1	7.6961517334	7.6961517334	7.6961517334	7.6961517334
2	10.0994110107	10.1089477539	10.1089477539	10.1089477539
3	12.0258331299	12.0258331299	12.0258331299	12.0735168457
4	15.5448913574	15.5448913574	15.5448913574	15.5448913574
5	24.4617462158	24.4617462158	24.4617462158	24.4617462158
6	68.6740875244	68.359375	68.6740875244	68.6740875244
7	69.4847106934	69.4847106934	69.5133209229	69.7135925293
8	146.4080810547	146.2745666504	146.4080810547	146.4080810547
9	164.3085479736	164.1368865967	164.3085479736	164.3085479736
10	165.4148101807	165.4148101807	165.4148101807	165.4148101807
11	193.4337615967	193.7389373779	193.3193206787	193.3193206787
12	289.5832061768	289.5832061768	289.5832061768	289.5832061768
13	291.2330627441	291.2330627441	291.2330627441	291.2330627441
14	299.9019622803	299.9019622803	299.9401092529	299.9019622803
15	599.8611450195	599.8611450195	599.8611450195	599.8611450195

Table 1: Resonances of Cavity 1 to 4.

nances, only the excitation is different. Furthermore the resonances do not agree with the frequencies given in [5]. Therefore, the assumption is that the measurements have shown the resonances of the modules and not of the cavities.

### RESONANCE MONITOR MEASUREMENTS

Another way to measure the deviation of center frequency of a cavity is to use a resonance monitor shown in Figure 8 in parallel to the RF system in normal, closed loop operation. With this resonance monitor it is possible to detect the phase error in reference to the center frequency of the cavity without using any part of the low level RF-system. The PXI-6115 analog to digital converter board in the PXI-1042 main frame was used for data recording again. The sampling rate was chosen again to 20 kSample/s, equal to an upper frequency limit of 10 kHz, and the amplitude resolution of the PXI-6115 card was chosen to be 12 Bit.

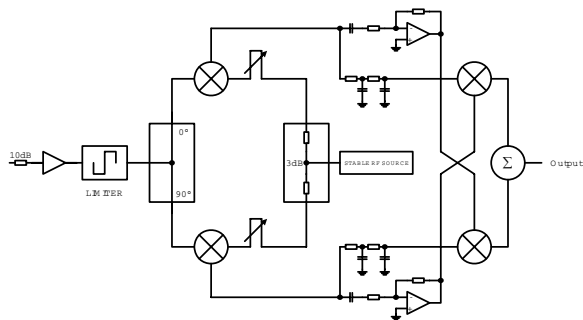

Figure 8: Circuit of the used Resonance-Monitor.

Some results are shown in Figure 9. Again the resonances do not agree with the frequencies given in [5].

### MEASUREMENTS BY LORENTZ FORCE

For the measurement of mechanical eigenmodes of the cavities excited by amplitude modulation of the RF-signal,

and therefore energy modulation of the beam, a DSP lock-in amplifier SR850 from Stanford research System [4] was used. The functional block diagram of the SR850 DSP Lock-In Amplifier is shown in Figure 10. The functions in the gray area are handled by the digital signal processor (DSP). The sine output was added to the DC gradient control signal on a sum point for amplitude modulation and the input of the lock-in amplifier was connected with the phase controller signal. It will be supposed that mainly cavity resonances are measured.

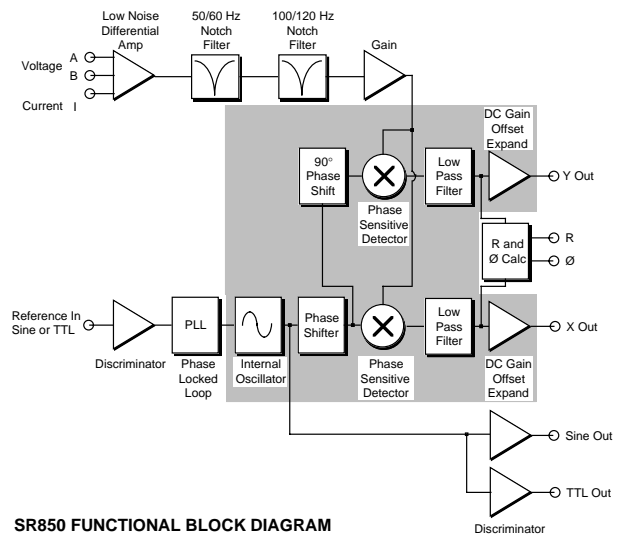

SR850 FUNCTIONAL BLOCK DIAGRAM

Figure 10: SR850 Functional Block Diagram [4], used with permission.

The measured amplitude and phase of the power spectral density of phase controller signal are shown in Figure 11.

### MEASUREMENTS OF BODY SOUND

To find the sources of microphonics, measurements with a body sound sensor (geophon, sensitivity about 30mV/mm/s) in connection with a low noise LF amplifier (amplification 1000) were carried out. For recording the data the already-described LabView application on the PXI-system was used again. In Figure 12(a) to Figure 12(d) some of the results are shown. Very strong sources

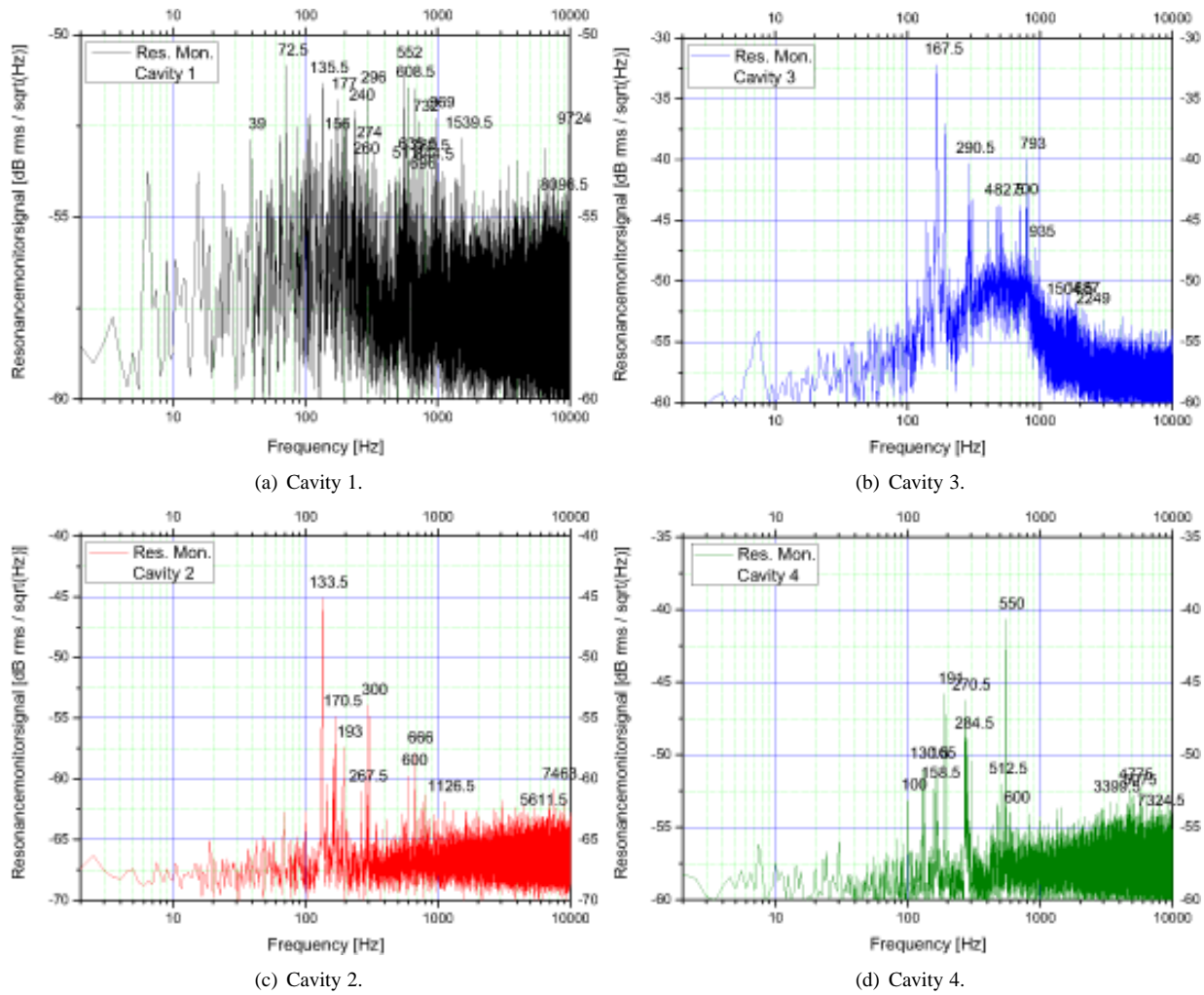

Figure 9: Power spectral density spectra of resonance monitor output signals for cavity 1 to 4.

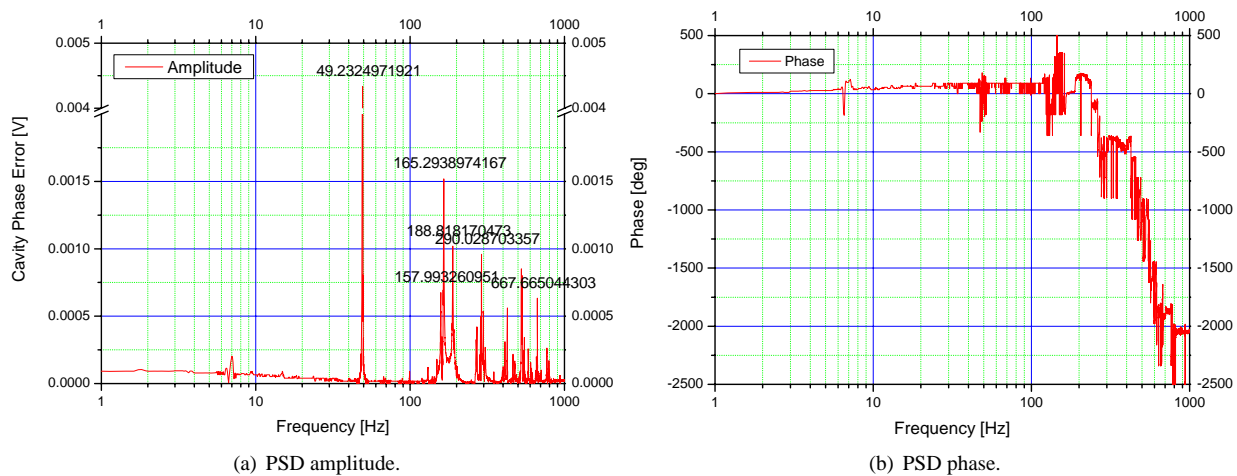

Figure 11: Amplitude and Phase variation of power spectral density due to the Lorentz force excitation of mechanical eigenmodes.

of microphonics are the He-compressors, cooling water pumps and also the air-conditioning system. The energy of these sources is unfortunately concentrated in the fre-

quency range from 10Hz up to 100Hz.

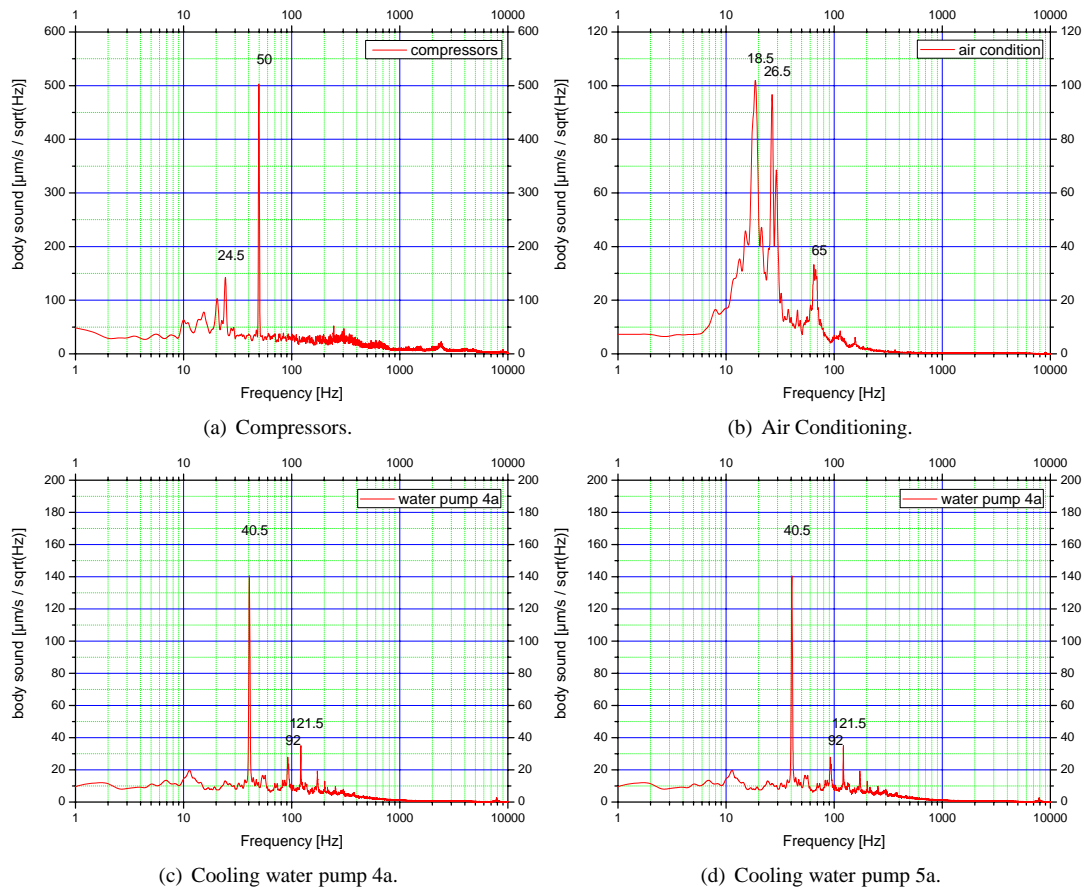

Figure 12: Some power spectral density spectra of body sound sources at ELBE.

## CONCLUSIONS

All cavities shows significant energy dependency of microphonics excitation at high gradients, caused by the heavier cooling load of the helium machine due to the higher losses in the cavities.

Measured peak frequencies of the microphonics however on all 4 cavities are very similar. The peaks are unequal to calculated values for the mechanical self resonances of single cavities without housing known from Schilcher [5]. Therefore a strong mechanical coupling of the cavities in the modules will be supposed.

Module 2 microphonics is more excited by microphonics as module 1, caused by internal mechanical resonances in the frequency range 10Hz up to 100Hz. The origin of this difference could be construction differences in the inner of the modules, which is not accessible. This should be cured.

Main excitation source are the He-compressors, the water coolant pumps and also the air-conditioning system. All these source are mainly located in the frequency range between 10Hz and 100Hz. Therefore a mechanical construction without resonances in this range would be major progress.

## ACKNOWLEDGEMENT

This work has been supported by the EU Commission in the Sixth Framework Program, Contract No. 011935-EUROFEL and Contract No. RII3-CT-2003-506395-CARE. And we acknowledge the support of the German Federal Ministry of Education and Research grant 05 ES4BR1/8.

## REFERENCES

- [1] B. Aune et al., "The Superconducting TESLA Cavities", DESY'00-031, February 2000, DESY Hamburg.
- [2] H. Buettig et al., "Analog RF Control of ELBE Modules", DS'5.13, 2007, FZD Dresden.
- [3] A. Buechner et al., "Noise Measurements at the RF System of the ELBE Superconducting Accelerator", EPAC'02, June 2002, Paris.
- [4] Stanford Research Systems, "DSP Lock-In Amplifier Model SR850", Stanford Research Systems, October 1999, Sunnyvale.
- [5] T. Schilcher, "Vector Sum Control of Pulsed Accelerating Fields in Lorentz Force Detuned Superconducting Cavities", DESY, TESLA FEL Report 98-20, August 1998, Hamburg.