

REVIEW OF CRYOMODULES AND SRF CHALLENGES FOR LIGHT SOURCE ENERGY RECOVERY LINACS

Alireza Nassiri, ANL, Argonne, IL 60439, U.S.A

Abstract

Superconducting rf (SRF) is the technology of choice for future energy-recovery linac (ERL)-based light source facilities. ERL-based light sources are required to run in a continuous wave (cw) mode as compared to the International Linear Collider (ILC), which requires a moderate repetition rate. The difference in the two operating modes (low duty factor and cw) will necessitate a fresh look at the SRF parameter space specifically suited for light source ERLs. There are still open questions regarding the choice of rf frequencies, cryomodule design, cavity cell design and number of cells, Q factor, accelerating gradient, and higher-order-mode damping. In addition, the cryoplant for such facilities will need to be designed to handle on the order of tens of kW of cooling at 2°K. The existing cryoplants cannot provide a level of efficiency to make it cost effective to operate such facilities. Therefore, consolidated R&D efforts are needed to find a more robust solution to improve the overall refrigeration efficiency.

INTRODUCTION

The ERL was first described as an option for colliding beams by Tigner [1]. Only much later [2] was its potential as a possible x-ray light source explored. The ERL concept, illustrated in Figure 1, assumes an electron gun delivering an essentially continuous stream of bunches.

These bunches are delivered at an energy (typically) of 5 to 15 MeV into a linear accelerator, through a set of bending magnets called a merger. After acceleration, bunches are returned to the upstream end of the linac using a transport line system, which necessarily incorporates bending. This transport system provides the opportunity to create synchrotron radiation through the incorporation of undulator magnets, for example. Upon

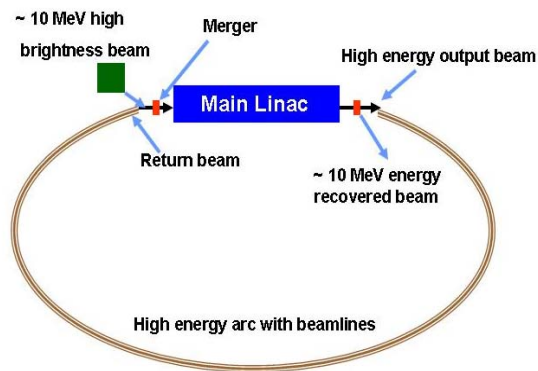

Figure 1: Schematic of an ERL-based light source.

returning to the upstream end of the linac, the high-energy beam is merged back into the linac. By proper choice of path length for the transport line, the rf phase of the high-energy beam can be retarded by 180 degrees relative to the accelerating beam. Thus, the high-energy beam is decelerated and returns its energy to the rf fields in the cavities, which accelerate the new beam. Typically, ERLs make use of superconducting (SC) rf systems in order to ensure the greatest efficiency of energy recovery. Typical rf cavity parameters for existing and proposed ERL facilities are summarized in Table 1.

HIGH AVERAGE CURRENT SRF LINACS

The high average current necessitates cw operation of light source-based machines, thus SRF technology is required. Furthermore, high average currents of fractions of an ampere (e.g., 100 mA) at multi-GeV (e.g., 5 to 10 GeV) have hundreds of megawatts of beam power, therefore high average current also requires energy recovery to be practical [3].

The consequences of high average current ERLs are given here. 1) There is no need for high-power fundamental power couplers for the main linac. 2) For the injector linac complex, which is not energy recovered, very high-power input couplers are required. For example, for a 10-MeV injector linac with an average current of 100 mA, the total beam power is one megawatt. For a 5-cavity system with one input coupler per cavity, each fundamental power coupler has to be designed to operate at 200 kW. This in itself is very challenging. 3) It is desirable to operate the main linac cavities at high Q_{ext} to minimize rf power requirements but with implications of microphonics [4]. Since the power bill for a large SRF ERL is mainly dominated by cryogenic requirements, it is imperative to achieve as high a cavity quality factor (Q_0) as possible for reasonably acceptable field gradients (16-20 MV/m). This range of gradients ensures emission-free cavities. A potential increase in Q_0 (e.g., 10^{10} to 2.5×10^{10}) would result in significant power savings for 2°K refrigeration. A reported $Q_0 = 10^{11}$ for a single-cell, 1300-MHz cavity from the SACLAY group is encouraging.

Several factors play key roles in improving and maintaining such high Q_0 , including optimal cryogenic temperature and extremely good magnetic shielding to minimize residual resistivity. A new and optimized cryomodule design for high current ERL operation is desirable.

SRF LINAC RF POWER REQUIREMENTS

Since the beam loading of the accelerated and decelerated beam cancels, ideally there is no effective

Table 1: Existing and Proposed ERL Main Parameters

	TJNAF	ERLP	JAERI	4GLS	BNL	BINP	Cornell	APS
E [MeV]	160	35	17	600	20	12 50 (upgrade)	5000	7000
I_{ave} [mA]	9	0.013	5 40 (upgrade)	100	500	20 50 (upgrade)	100	100
Q_{bunch} [PC]	270	80	500	77	1300	900 2200 (upgrade)	77	77
$\epsilon_{N,rms}$ [μ m]	7	5	30	2	<10	20	< 0.5	< 0.5
Rep. Rate[MHz]	74.85	81.25	20.8 80 (upgrade)	1300	9.38- 371.875	22.5	1300	1400
Accelerator frequency [MHz]	1500	1300	500	1300	740	180 Copper cavity	1300	1400
E_{acc} [MV/m]	20	13.5	7.5	15.2	13	0.7	16	18

beam loading for the accelerating cavity mode. The rf source power (P_S), which requires providing the necessary accelerating voltage (V_{acc}) for the main linac, is given by [5]

$$P_S = \frac{V_{acc}^2}{4 \frac{R}{Q} Q_{ext}} \left\{ 1 + \left(\frac{\delta\omega 2Q_{ext}}{\omega_c} \right)^2 \right\},$$

where $\delta\omega$ is the microphonic tolerance bandwidth.

It should be noted that having reasonable operational flexibility in the adjustment of Q_{ext} is clearly advantageous when trying to minimize the input rf power to a string of cavities, each with their own microphonic sensitivities. It is certainly advantageous to push the cavity operating Q_{ext} toward a higher value in order to have substantial rf power cost-savings impact. A high Q_{ext} implies a narrow resonance of the superconducting cavity; therefore, microphonic vibrations can cause large phase and amplitude fluctuations that need to be corrected if a certain value of energy spread is to be maintained at the exit of the linac. Furthermore, for high-gradient and high- Q_{ext} cavities, the Lorentz force (radiation pressure) during gradient turn-on can shift the resonant frequency of the cavity by several bandwidths of the cavity resonance, resulting in operational difficulty and, under certain conditions, unstable behavior [6]. Mitigation of these fluctuations is possible with the design of a robust LLRF system allowing operation at higher external Q values. Experiments at the JLab ERL, using the Cornell-developed digital LLRF have successfully demonstrated phase and amplitude stability of 0.02° and 10^{-4} , respectively, with $Q_{ext} = 1.2 \times 10^8$ at 5 mA in energy recovery mode. These initial results are very encouraging, although further investigation and development of an LLRF system are needed to support higher average beam current up to hundreds of milliamperes.

To deal with a large range of microphonics (up to 40 Hz), it is desirable to design a variable input coupler with Q_{ext} adjustable from 10^7 to 10^8 , while maintaining a modest rf power requirement of roughly 12 kW. Active microphonics compensation with piezo tuning will be required to ensure adequate rf stability control.

Figure 2 shows how the magnitude of the microphonics affects the required rf operating budget.

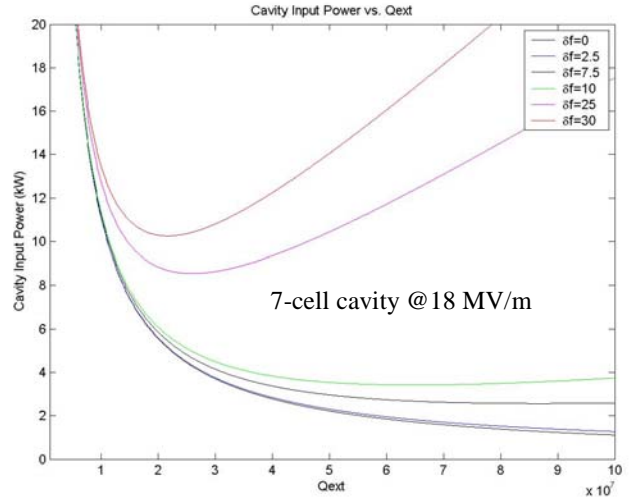
 Figure 2: Microphonics impacts on Q_{ext} and rf power.

HIGHER-ORDER MODES (HOMs)

Efficient extraction of higher-order mode (HOM) power generated by picosecond short bunches must be ensured. High-average-current (~ 100 mA) and short-bunch-length beams in superconducting cavities excite HOMs, which, in addition to affecting beam stability, could result in increased cryogenic load due to power dissipation in the cavity walls. The power in HOMs, primarily longitudinal, depends on the product of bunch charge q and the average current I_{ave} , and is equal to $2qk_{||}I_{ave}$, where $k_{||}$ is the loss factor of the superconducting cavity and the factor 2 accounts for the two beams in the cavity. The total power depends on the bunch length through the loss factor. At high currents and short bunches (e.g., APS and Cornell) the amount of dissipated power can be quite high. For example, for ERL@APS, with an average current of 100 mA, bunch charge equal to 77 pC, and $k_{||}=10$ V/pC, the HOM power is approximately equal to 154 W per cavity. Part of this power is expected to be extracted

by HOM couplers and absorbed in room-temperature loads, and part of it is expected to be absorbed by cooled photon absorbers placed between cavities or cryomodules. According to Bardeen, Cooper, and Schrieffer (BCS) theory, the excitation of high-frequency HOMs by the short bunches can adversely affect the cavity's quality factor and increase power dissipation in the cryogenic environment [7]. Therefore, a rigorous analysis of modes in a cavity is necessary to develop an efficient and cost-effective design. The complex structure of multi-cell cavities cause modes to be trapped inside the cavity, thus limiting the performance due to beam instabilities. There are two main reasons for HOMs being trapped inside the cavity structure [8]: 1) The end cell geometry is different from that of the middle cells. This may result in poor cell-to-cell coupling and cause HOMs to get trapped inside the structure; 2) It is possible to find HOMs below the cutoff frequency of the beam pipe, preventing the mode from propagating out of the structure. These modes exponentially decay in the beam pipe before they reach the ferrite absorbers.

It is very important to carefully analyze such trapped modes and to modify the cavity structure (shape and number of cells) to propagate them. Cavity cell shape optimization is necessary to achieve good rf efficiency and good HOM damping, and, with HOMs tuned to safe frequencies, to minimize power extracted from the beam, which can be a severe problem for high-current machines [9]. It is equally important to minimize the cryogenic losses at 2°K by absorbing HOM power into ferrite loads placed in the warm section.

Jefferson Laboratory is designing high-power HOM loads with SiC ceramic tile absorbers capable of dissipating up to 4 kW each with a good safety margin for its Ampere-class module. Simulation results indicate good broadband frequency response up to 8 GHz [10]. Further design studies, tests, and cost optimization are needed.

INJECTOR LINAC

One of the most challenging components of a high-current ERL is the injector SRF linac. In cw operation, the cavities not only have to transfer a total of 1000 kW (100 mA, 10 MeV) to the beam, but have to do so without destroying its ultra-low emittance. These requirements together with a high beam current and short bunch lengths of less than 600 μm put high demands on the superconducting cavities, the higher-order-mode (HOM) damping scheme, the rf input couplers, and the cryovessel itself [11]. The Cornell group has developed two prototype ERL cw 1.3-GHz input couplers that were fabricated by industry and have been high-power tested. These couplers reached 50 kW in cw operation, but insufficient cooling of some coupler sections was found [12]. For a high-current ERL injector linac, an input coupler with power handling capability of 200 kW cw or so is desirable.

REVIEW OF CRYOMODULES

ERLP Module

The ERLP cryomodule consists of two 1.3-GHz 9-cell cavities provided by Stanford University (see Figure 3). Cornell University is providing the HOM absorber design to be incorporated into the cryomodule, and DESY is providing 7-cell TESLA/TTF cavities, which will be modified by Cornell and integrated by Daresbury. LBNL, FZE Rossendorf, and Daresbury are providing engineering resources to facilitate the integration process, in particular with regards to the mechanical and rf optimization. After considering three options for the input coupler, the Cornell injector adjustable coupler capable of handling up to 50 kW cw was selected. Modifications were made to the coupler unit to shorten the cold section of the coupler by 15 mm in order to resolve the conflicts with the N2 skeleton.

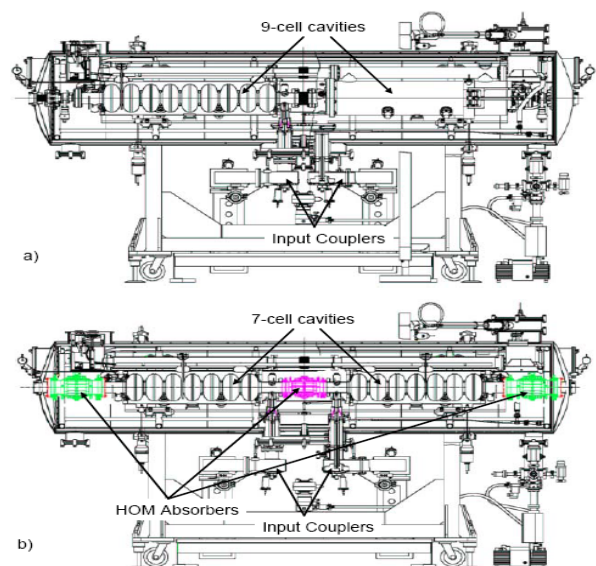

Figure 3: ERLP cryomodule: a) original and b) modified cavity and cryomodule.

JLab High-Current Module

JLab has developed a 748.5-MHz Ampere-class cryomodule concept aimed at high power compact ERL-based FELs. This concept employs multi-cell waveguide damped cavities with room temperature HOM loads and high-power waveguide fundamental power couplers. As part of the prototyping effort, cavities and components have been produced at 1497 MHz (see Figure 4) to take advantage of the existing production and testing infrastructure at JLab. The cavity cell shape has been optimized for good rf efficiency, good HOM damping, and with HOMs tuned to safe frequencies to minimize HOM power extracted from the beam, which can be a severe problem for high-current machines.

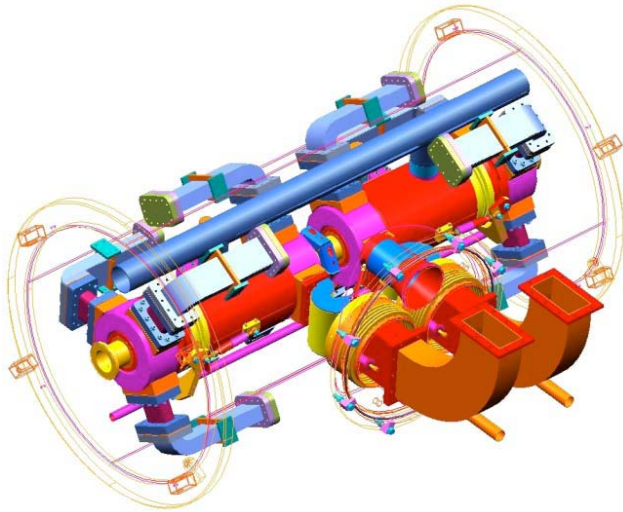

Figure 4: 1.5-GHz high-current cavity pair concept.

High-power HOM loads with SiC ceramic tile absorbers are being developed. It is expected that these loads will be capable of dissipating up to 4 kW each (see Figure 5).

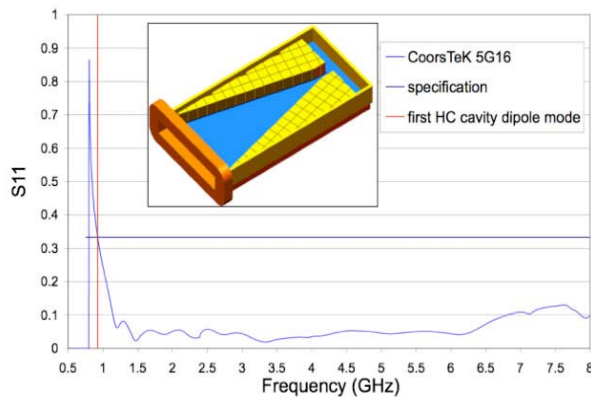

Figure 5: Simulation result: S_{11} of high-power load using SiC absorber.

A high power window concept has been developed based closely on the successful B-factory and LEDA windows. This has been prototyped in WR650 for use at 1497 MHz with cavity prototypes but can be scaled anywhere from 1.3 to 1.5 GHz by simply changing the ceramic thickness.

CORNELL INJECTOR MODULE

Cornell's ERL injector module and the horizontal test module design is based on the Tesla Test Facility (TTF) cryomodule, with beamline components supported from a large-diameter helium gas return pipe and all cryogenic piping located inside the module. Significant modifications were made to the TTF module to fulfill ERL-

specific requirements. Figure 6 shows a 2D cross section of the injector module.

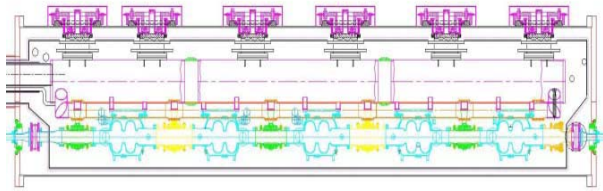

Figure 6: 2D cross section of Cornell ERL injector module.

The assembly of the ERL horizontal test cryomodule (HTC) is nearly finished. The HTC follows the same design as the full injector cryostat but has only one cavity with two HOM loads instead of five cavities with six HOM loads. The HTC beamline string (see Figure 7) consists of a prototype 1.3-GHz 2-cell cavity, two Cornell ERL prototype HOM loads, and two prototype Cornell ERL cw 1.3-GHz input couplers, which have been fabricated by industry and have been high power tested at Cornell. The specified maximum rf power of 50 kW was reached in cw operation, but insufficient cooling of some coupler sections was found. The coupler design was modified to increase cooling of these sections, and additional couplers are under fabrication in industry. The frequency tuner for the 2-cell module has been adopted from the DESY/INFN blade tuner design. Short piezoelectric actuators have been integrated in the frequency tuner mechanism to allow for fast microphonics compensation.



Figure 7: Cornell HTC beamline string.

BNL AMPERE-CLASS MODULE

The BNL 5-cell cavity has been designed for use in their high-average-current energy recovery linac, which is being built as a proof-of-principle system for the future RHIC II upgrade. A conceptual cryomodule design is shown in Figure 8.

The 5-cell cavity is designed to operate at 20 MV/m and a Q_0 of 10^{10} . The cavity was built by Advanced Energy Systems (AES) and then shipped to JLab for chemical treatment and rf testing in the vertical test dewar (VTA). Following the JLab chemical processing recipe,

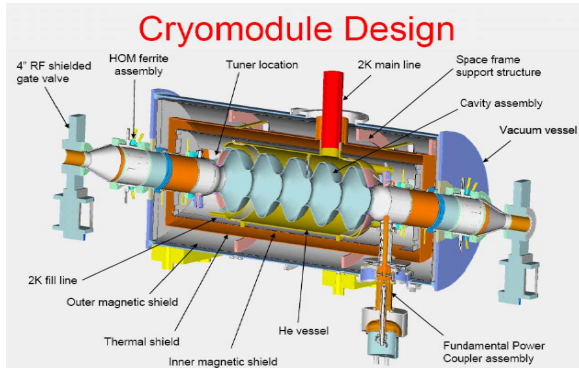

Figure 8: BNL Ampere-class cryomodule design.

a gradient of only a few MV/m was reached. The problem was attributed to a flange, which was fitted with two titanium half-nipples for vacuum pumping and rf power input. It was discovered that due to the dimensions of the beam pipe, there was appreciable magnetic field at the flange, and the titanium half-nipples were found to be beaten up. The flanges were replaced by all-Nb flanges and the cavity reached 12 MV/m.

Due to numerous and significant field emissions, helium processing was carried out, which resulted in significant accelerating field improvement but with a continuing high radiation level. Following a low temperature bake (100°C), a He vessel was attached to the cavity under vacuum.

Subsequent testing of the unit resulted in an accelerating gradient of 20 MV/m at $Q_0=10^{10}$ (see Figure 9). The cavity will be assembled into a hermetic string and shipped back to BNL for commissioning.

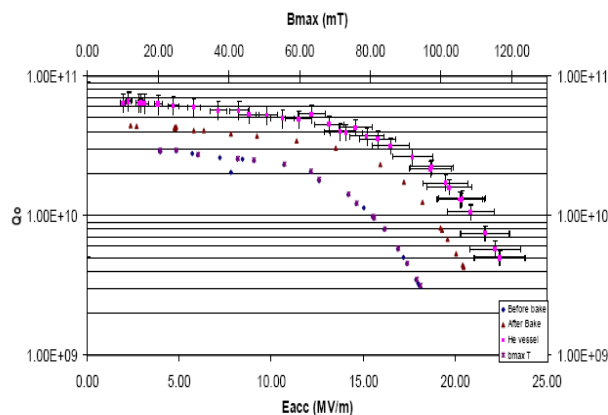

Figure 9: Plot Q_0 vs E_{acc} for the 5-cell cavity. Before bake (blue circles), after bake (red triangles), and with the He vessel (turquoise).

ELBE CW MODULE

The ELBE cryomodule consists of two cavities that are assembled with the main power couplers in the center of the module. The tuners for each cavity are at both ends.

The two tanks containing He are made of titanium. A titanium bellow at one side of the tank is connected via two chimneys with the two-phase helium supply tube above the cavities. The 80K liquid nitrogen shielding uses liquid nitrogen. The cavities are passively shielded against ambient magnetic fields by means of a cylindrically shaped mu-metal sheet, closed at both sides, which is placed between the 80K liquid nitrogen shielding and the stainless-steel vacuum vessel. The use of titanium spokes for the cavity support, thin stainless-steel bellows in the beamlines and rf couplers, as well as the multi-layer superinsulation foils, ensure low thermal losses of the cryostat (see Figure 10).

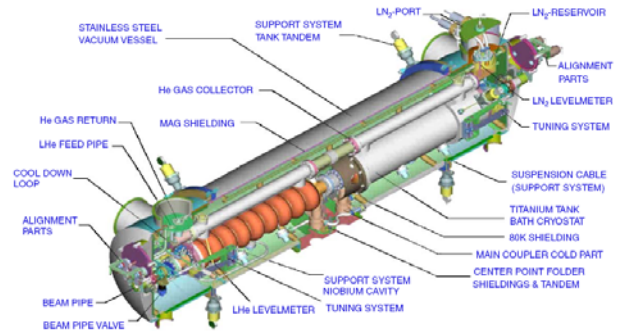

Figure 10: ELBE cryomodule.

A coaxial main power coupler for cw operation was developed in collaboration with the HEPL at Stanford University. The coupler is designed for 10 kW. The main power coupler is a critical part of the accelerator module. In order to prevent damage, sophisticated diagnostics have been installed. The coupler windows are monitored with respect to temperature, vacuum pressure, and electric discharges. The ELBE module tuner design is a spindle-lever system where the two levers act on the movable endplate of the cavity, whereas the support is attached to the helium vessel.

After fabrication and treatment, the cavities were tested in the vertical test cryostat at DESY. The measured intrinsic quality factor was about 2×10^{10} and the maximum acceleration gradient was between 18 and 25 MV/m. For the installed cavities in the cryostat assembly, the dissipated power strongly increases for acceleration gradients at 8-10 MV/m. These values are much lower than the maximum gradients measured in the vertical tests. During this test, a strong increase of X-ray emission was observed. One can assume that the gradient effect comes from field emission. The strong increase of the dissipated power causes the helium plant's cooling capacity and pressure stability to quickly reach their limits at these gradients. Test results indicate that the ELBE cryomodule is suitable for cw operation at accelerating gradients in the range of 10 MV/m and with an average current of 1 mA. Most of the module's parameters are equal to or better than its design specifications. The accelerating gradient is restricted by field emission in all cavities. The current of 1

mA (10 kW rf power) seems to be near to the limit of fundamental power couplers.

IMPROVING Q_0

The wall-plug power requirement for high-current light source ERLs is on the order of tens of megawatts. Design, implementation, and operation of a large cryoplant are very challenging, not to mention the huge operational cost. It is therefore necessary to improve existing processing techniques, and in parallel, to explore suitability of other SC materials to obtain and retain a very high cavity quality factor (Q_0). Improving cavity Q_0 by a factor of 2 will result in many megawatts reduction in wall-plug power. Godeke [13] has studied the suitability of Nb₃Sn to improve SRF cavity quality factor at 4.2K. The potential advantage of Nb₃Sn for rf cavity applications, due to the material's superior intrinsic properties compared to Nb, is promising. Further research is required to investigate its applicability to large-scale SRF cavities production.

Gurevich [14] has studied and shown that the rf breakdown magnetic field of superconducting cavities can be significantly enhanced by a multilayer coating consisting of alternating insulating layers and thin superconducting layers of thickness smaller than the London penetration depth. Such a coating increases the field of vortex penetration and the quality factor determined by a small surface resistance R_s in the Meissner state. This may offer new opportunities for optimizing cavity performance by increasing the cavity quality factor Q_0 .

Suppression of multipactoring and field emission are essential for the cavities' operation. Multipactoring refers to runaway electron emission due to high secondary electron emission of oxygen-covered Nb surfaces. Atomic layer deposition (ALD) can be used to reduce the secondary electron yield below one, thus suppressing the effect. The field emissions can produce electrical arcs, which damage cavities. Significant effort has been devoted to chemical mechanical polishing of the Nb surfaces to increase the electrical field strength limits. Conformal coating of these surfaces should improve the situation by increasing the radius of curvature of the remaining high aspect ratio structures [15,16].

Magnetic field quenching of the cavity is also a concern. For rf cavities this limit is critically dependent upon the surface properties of the Nb material. Although niobium has the highest lower critical field limit of any material, its surface oxide properties have made it difficult to achieve these limits. It is expected that a capping layer (tens of nm alumina) of the Nb surface can solve much of this problem.

SUMMARY

Tremendous progress has been made over the past years in advancing the cw SRF cavity and cryomodule technology. Test facilities worldwide are either in full operation, under construction, or undergoing commissioning to resolve outstanding physics and engineering issues. The

work reported in this paper is a small sample of these exceptional efforts.

There still remain numerous SRF challenges for high average beam current energy recovery linacs for light sources. The SRF challenges and R&D efforts include the design of an optimized shaped multi-cell cavity with good rf efficiency and strong damping of the HOMs of the monopole and dipole modes. Longitudinal wakes excited by high average current, short bunch length beams in SRF cavities, in addition to causing beam quality degradation, also give rise to HOM power, which can be significant (up to a few kW) and extend over high frequencies (of order hundreds of GHz). The challenge is to ensure adequate damping of HOMs and the extraction of HOM power with good cryogenic efficiency.

Development of a robust high-power fundamental power coupler (FPC) is essential to meet the ERL injector linac requirement. In the injector cavities, a high average rf power must couple to a vulnerable low-energy beam. In addition to input coupler challenges resulting from the high power handling, a second major challenge is to not disturb the beam.

Rf field control of high loaded quality factor is a challenge due to microphonic detuning and random beam loading. It is desirable to have a $Q_{\text{ext}} = 10^8$ with field stability of 10^{-4} for amplitude and 0.02° for phase for 100-mA operation.

Improving the cavity quality factor Q_0 is important to reduce the size and the wall-plug power of the cryoplant. Increasing the cavity quality factor from 2×10^{10} to 5×10^{10} will be of tremendous benefit. Material science can play a defining role in providing answers to this challenge.

ACKNOWLEDGMENTS

The author is grateful to Todd Smith (Stanford University) for his encouragement and fruitful discussions on SRF. This review paper has benefited from input from my colleagues at Argonne: K. Shepard, M. Kelly, M. Borland, K. Harkay, R. Kustom, G. Waldschmidt, and M. White. The author additionally benefited from discussions with R.A. Rimmer, L. Merminga, G. Krafft (TJNAF), P. A. McIntosh (Daresbury), G. Hoffstaetter (Cornell), and I. Ben-Zvi (BNL).

This work was supported by the U.S. Department of Energy, Office of Science, Office of Basic Energy Sciences, under Contract No. DE-AC02-06CH11357.

REFERENCES

- [1] M. Tigner, *Nuovo Cimento* 37, 1228-1231 (1965).
- [2] I. V. Bazarov et al., *Proc. 2001 Particle Accelerator Conference*, Chicago, Illinois, June 18-22, 2001, 230-232 (2001).
- [3] I. Bazarov and C. Sinclair, *Phys. Rev. ST Accel. Beams*, 8, 034202 (2005).
- [4] M. Liepe et al., *Proceedings of the 2005 Particle Accelerator Conference*, Knoxville, Tennessee, May 16-20, 2005, 2642-2644 (2005).

- [5] M. Liepe et al., Proceedings of the 2003 Particle Accelerator Conference, Portland, Oregon, May 12-16, 2003, 1329-1331 (2003).
- [6] J.R. Delayen, "Phase and amplitude stabilization of superconducting resonators," PhD thesis. Calif. Inst. Tech. (1978).
- [7] L. Merminga, Proceedings of XX International Linac Conference, Monterey, California, August 21-25, 2000, 860-862 (2001).
- [8] R. Calaga et al., "Study of Higher Order Modes in High Current Multi-cell SRF Cavities," C-A/AP/#11, September 2003.
- [9] H. Wang et al., Proceedings of the 2005 Particle Accelerator Conference, Knoxville, Tennessee, May 12-16, 2005, 4191-4193 (2005).
- [10] R.A. Rimmer et al., Proceedings of the 2007 Particle Accelerator Conference, Albuquerque, New Mexico, June 25-29, 2007, 2493-2495 (2007).
- [11] M. Liepe et al., Proceedings of the 2005 Particle Accelerator Conference, Knoxville, Tennessee, May 12-16, 2005, 4290-4292 (2005).
- [12] S. Belomestnykh et al., Proceedings of the 2006 European Particle Accelerator Conference, Edinburgh, Scotland, June 26-30, 2006, 472-474 (2006).
- [13] A. Godeke, "Nb₃Sn for Radio Frequency Cavities," LBNL-62140, December 8, 2006.
- [14] A. Gurevich, "RF breakdown in multilayer coatings," SRF Material Workshop, FNAL, Batavia, IL, May 23-24, 2007.
- [15] J. W. Elam et al., "Atomic Layer Deposition for the Conformal Coating of Nanoporous Materials," Journal of Nanomaterials, 2006, ID-64501, 1-5, (2006).
- [16] M. Pellin, "Atomic layer deposition," SRF Material Workshop, FNAL, Batavia, IL, May 23-24, 2007.