

SUPERCONDUCTING RF AND RF CONTROL FOR ENERGY-RECOVERY LINACS: SUMMARY OF WORKING GROUP 3 AT ERL 2007

Todd I. Smith*, Hansen Experimental Physics Laboratories, Stanford CA, 94303, USA
 Robert A. Rimmer, Thomas Jefferson National Laboratory, Newport News, VA, 12345, USA
 Stefan Simrock, Deutsche Elektronen-Synchrotron, 22607 Hamburg, Germany

Abstract

The 2nd Workshop on Energy Recovery Linacs (ERL 07) was held May 21-25, 2007 at Daresbury Laboratory in England. In the same manner as the 1st workshop, ERL 05, held in the United States at the Jefferson Lab, four working groups were established. This is a summary of Working Group 3 (WG3), set up to study the general topic of “Superconducting RF and RF Control for ERLs”.

INTRODUCTION

Energy Recovery Linacs (ERLs), first proposed in 1965[1], are currently receiving a great deal of attention as potential sources of intense, high brightness electron beams for use in future light sources and free electron lasers. The intensity is provided by CW operation of the linear accelerator at high average current, while low emittance results from preservation of the electron source emittance while accelerating and using the beam.

While CW operation at high current does not, strictly speaking, require the use of energy recovery, the laws of economics do. For example, a 100 mA, 5 GeV beam represents a power requirement of 500 MW if it is simply produced and discarded into a beam dump as in a traditional linear accelerator. However, as neither synchrotron radiation nor the FEL interaction extracts more than a small percentage of the electron beam energy, the power actually required is “only” in the range of 1 to 10 MW—if the unspent energy of the beam can be captured and reused. This is, of course, just the purpose of an ERL.

Storage rings represent the ultimate in energy recovery, and have served admirably to provide electron beams for synchrotron radiation production. However, the equilibrium emittance of the beam in a storage ring represents a balance between quantum excitation and radiation damping, and it appears that despite the best efforts of a motivated and talented community of storage ring scientists, advances in minimizing this balance beyond today’s state of the art will be minimal. The electron beam in an ERL only makes a few turns around the system before it is discarded and a fresh beam takes its place. Neither quantum excitation nor synchrotron radiation have much chance to influence the beam’s emittance, which is then dominated by the emittance of the source.

In addition to recovering the unspent beam energy, it is important that other power requirements operating the accelerator not be excessive. This dictates that the

acceleration be accomplished using superconducting, rather than normal conducting, RF cavities. A 5 GeV CW linac using normal conducting cavities would have to be about 5 km long and would require about 500 MW of power simply to maintain the accelerating fields against wall losses. A superconducting linac would be less than 1 km long and would only dissipate about 5 kW in wall losses at a temperature of around 2K. The refrigeration plant to produce the cooling would use around 5 MW, a factor of 100 less than the normal linac.

The 41st Advanced ICFA Beam Dynamics Workshop on Energy Recovery Linacs (ERL07) was held May 21-25, 2007 at Daresbury Laboratory in England to assess the science and technology of all aspects of ERLs, and to address current challenges related to their construction and use. ERL07 was the 2nd such workshop, and like the 1st (ERL05, held at the Jefferson Laboratory in the United States) four working groups were established and tasked with studying various aspects of ERLs. Working Group 1 (WG1) was to deal with “Electron guns and injector designs”, WG2 with “Optics and beam transport”, WG3 with “Superconducting RF and RF system control”, and WG4 with “Synchronization and diagnostics/ instrumentation”.

This is a summary of the WG3 talks and discussions. The program of WG3 was organized into five sessions, each 4½ to 5 hours long. Each session had 4-6 speakers scheduled, with a mixture of invited overview and contributed talks. The conveners made certain that there was ample time for discussion during and between talks. The sessions were:

- 1) Cryomodules
- 2) Cavities
- 3) Tuners, Microphonics and RF
- 4) Control RF Sources and Couplers (Joint with WG1)
- 5) SRF and Beam Optics Issues (Joint with WG2)

The following sections will follow the session titles and subjects. The reader should be aware that the sections will not be a complete review of all of the talks; instead they will be a highly subjective view of what are perceived as the highlights of progress, or at least changes, in the field since ERL05. It is assumed that the reader is familiar with the review of WG3 from ERL05[2]. The reader is encouraged to browse the contents of the ERL-07 proceedings and/or the conference web site (<http://www.astec.ac.uk/ERL07/wg3.htm>) for details of the individual presentations or publications. Where possible references will be provided here; unfortunately,

*Todd.Smith@Stanford.edu

at the time of writing, many potential contributions have not been received.

SESSION 1: CRYOMODULES

The following five talks were presented in the session on cryomodules:

- Cryomodule overview Ali Nassiri (Fermilab)
- The CW ERL Cryomodule Peter McIntosh
Collaboration Project (Daresbury)
- The JLab High Current Bob Rimmer (JLab)
Cryomodule
- Low loss cryomodules Georg Hoffstaetter
intended for the main linac (Cornell)
- BNL Cryomodule Andrew Burrill (BNL)

The talks confirmed the ongoing enthusiasm of nearly a dozen laboratories worldwide for the potential of ERLs either as synchrotron light sources or as FEL drivers. Ali Nassiri's [3] overview talk reminded the participants of the challenges and parameters that need to be considered in an ERL specific cryomodule (minimize microphonics, possible operation at high loaded Q , minimize static losses for consistency with very high Q_0 cavities, ability to handle HOM powers at the 100 W level, ...). The other speakers concentrated on the status and plans of their individual laboratories.

Bob Rimmer and Andrew Burrill spoke about the ampere-class cryomodules being constructed at JLab and BNL respectively. JLab has plans at both 1500 and 750 MHz, for compatibility with their existing FEL systems, while BNL is building their cryomodule at 703.75 MHz for compatibility with its use in electron cooling for RHIC. HOM damping and removal of HOM power is clearly a major concern of these projects, and it is interesting to note the different philosophy employed by the two groups. BNL is using ferrite HOM loads in the beam pipes, while JLab is using waveguide coupling and loads. Fig. 1 shows the BNL and Fig. 2 the JLab designs.

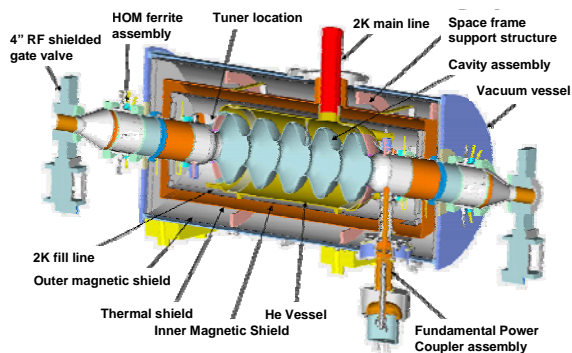

Fig 1: BNL ampere-class cryomodule.

Georg Hoffstaetter's presentation described the impressively detailed work the Cornell group has done, not only on their cavity and cryomodule designs, but on

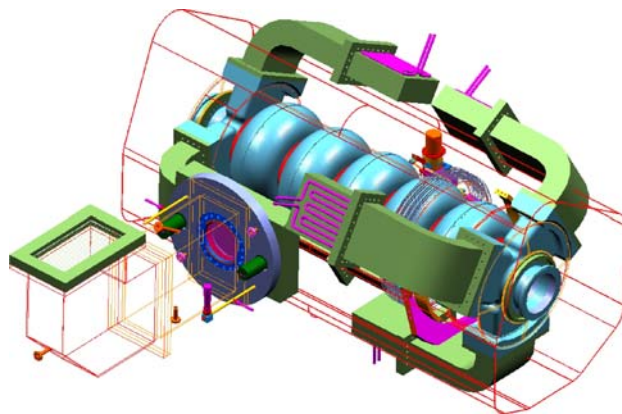

Fig. 2: The JLab ampere-class cryomodule.

optimization of the multi-dimensional parameter space of construction possibilities to minimize the project cost. As just one example, the working group was shown plots of total cost, capital cost, operating cost, tunnel length, number of cavities, IOT peak power, and cryo plant AC power as a function of cavity field gradient. Figure 3 shows the cost vs. field gradient and Q_0 .

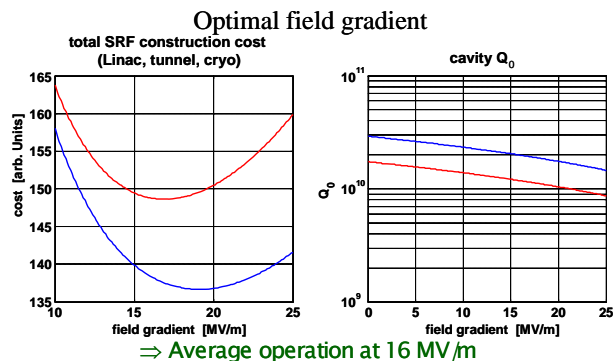
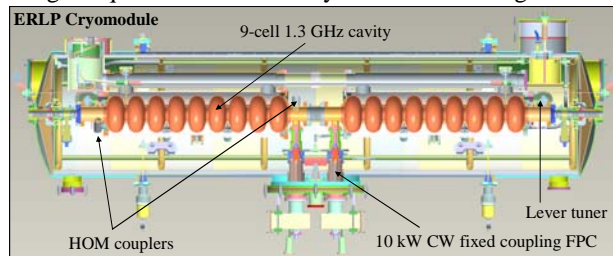

Fig. 3: Field gradient optimization

The final talk in the session, by Peter McIntosh, described the ERL Cavity/Cryomodule collaboration (Fig. 4). This is a cooperative effort involving 5 institutions and three countries. The five are: ASTeC (UK); Cornell, Stanford, and LBL (USA); and FZD Rossendorf (Germany). These institutions have pooled their resources to study problems and issues they have in common that would be difficult or impossible to study singly. The design requirements of the cryomodule are: large HOM



Stanford has provided a 2-cavity cryomodule (incl. some internals).
Cornell will provide and modify the 2 x 7-cell cavities.
DL will provide the HOM absorbers and couplers.
FZD have provided the 3D cryomodule drawings.
Engineering and design effort split across the 5 institutes

Fig. 4: The collaboration and the cryomodule

damping capability; $E_{acc} > 20$ MV/m @ $Q_o > 10^{10}$; $Q_e \approx 10^7$ to 10^8 ; and couplers capable of 25 kW CW. To meet these goals the team feels that issues to be resolved include: effective HOM damping (to 200W/cavity), sensitivity to microphonics, fast tuning, input power delivery, and overall cryomodule design.

One of the recommendations from ERL05 was that such collaborations be established. It is gratifying to see this example and to see the excellent work in progress.

SESSION 2: CAVITIES

The cavity session had four speakers scheduled. They were:

- SRF Cavity Shape Design Optimization for a High Current ERL Haipeng Wang (JLab)
- LBL Cavity modeling Steve Lidia (LBL)
- Development of a 1.3GHz superconducting cavity for the ERL main linac in Japan Takaaki Furuya (KEK)
- Experience with the TESLA cavities in CW-operation at ELBE Peter Michel (FZDR)

Haipang Wang discussed the methodology and results of an extensive optimization process used to define the cavity shape for the JLab high current cryomodule. Optimization was guided by the following, and led to the shape outlined in Fig. 5 which compares the JLab result (in black) with many other shapes used in various applications:

- Elliptical cavity design survey using a normalized inner cell shape and parameters.
- Maximize $R/Q \cdot G$ toward “low loss” concept but maintain the iris size in 140mm diameter for 750MHz cavity to reduce beam bunch longitudinal energy loss and transverse kick.
- Determine ERL (2-pass) CW beam excitation frequency spectrum and power deposition rate for 1A, CW / 0.1A, CW / pulsed beam etc.
- Optimize equator shape by flattening to maintain $R/Q \cdot G$ but keep trapped HOMs (below beam pipe cut-off frequency) away from beam excitation resonance to avoid huge power deposition. This was done by using cavity dispersion curves.
- Use 5-cell structure to avoid trapped modes in a long cavity.
- Use same cell shape in whole cavity, but trim end half cell equator shorter to get field flat. This avoids multi-die design and saves cost.
- Optimized shape also has to avoid multipactoring barrier.
- Determine BBU threshold based on the ERL optics. In second order, as for monopole modes, keep resonance frequencies away from the high R/Q dipole modes.

- Quadruple mode BBU will be the next level of optimization, as the threshold current is normally higher.

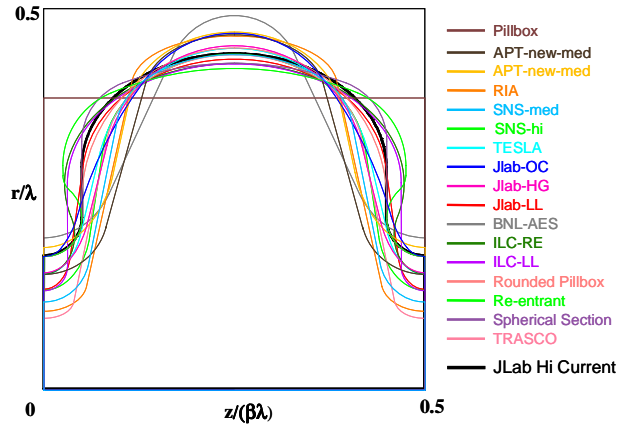

Figure 5: Normalized inner cavity shape comparison of various SRF programs. (JLab high current cavity is in black.)

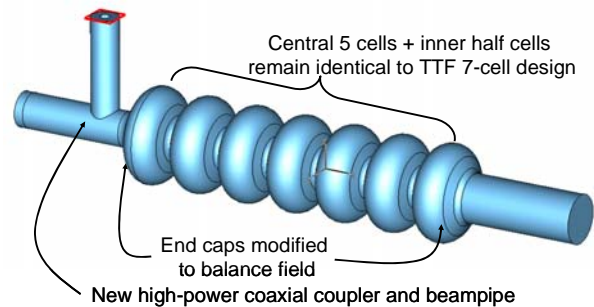

Fig. 6: Modifications to the TTF 7-cell cavity for higher average current operation.

Steve Lidia gave a talk describing the work at LBL, as part of the Cryomodule collaboration mentioned in the previous session, on modifying the TTF 7-cell cavity to optimize it for higher current operation. Particular attention was paid to field flatness and external coupling. Fig. 6 shows some of the changes being modeled.

Takaaki Furuya [4] gave a talk on the development of a 9-cell superconducting cavity for the main linac of the KEK ERL project. This 1.3 GHz cavity needs to support a 15-20MeV CW gradient and strong HOM damping as it will be run with a beam of 100 mA. The power coupler will be designed to tolerate 20 kW CW with full reflection, and the 100-200 W of HOM power will be absorbed with ferrite or SiC dampers. The group has done extensive modeling on the cavity geometry, with particular emphasis on HOM issues. Perhaps most intriguing is the addition of eccentric, short flutes to a beam pipe to convert quadrupole modes to dipole for propagation to the dampers. This innovation will be discussed specifically in the section on session 5, but it is worth pointing out here that their BBU simulations indicate that a 5 GeV ERL with these cavities would have

a BBU threshold of 0.6 A in a single loop configuration, and even in a two loop ERL the threshold would be 0.3 A. This suggests that 2-loop systems be seriously considered as cost and space saving configurations. Fig. 7 shows the cavity and some of its parameters.

1. Cell shape & beam pipe optimized from TESLA 9 cell cavity
 - Enlarge Iris diameter to 80mm, elliptical shape at equator
 - Cavity diameter 206.6 mm
2. Large beampipe with microwave absorbers
 - Beampipe diameter 120mm & 100mm
3. Eccentric fluted beampipe allows quadrupole HOMs to propagate



Accelerating mode parameters

Frequency	1300 MHz	Coupling	3.8%
Rsh/Q	897 Ω	Qo x Rs	289 Ω
Ep/Eacc	3.0	Hp/Eacc	42.5 Oe/MV/m

Fig. 7: KEK-ERL model-2 cavity

The final talk in the session was given by Peter Michel [5] who described the experience gained at ELBE from operating TESLA cavities over a several year period. The facility has four TESLA cavities and they have collected data on each. He described the initial Q_0 of the cavities before assembly into a cryomodule and the Q_0 after 4 years of operation and showed that all of the cavities had degraded-some by a factor of two, others by a factor of 10 at 10 MeV/m. He also described how they could use their normal RF system to pulse the cavities for tens of ms to gradients where there was substantial field emission, and the field emission would gradually process away and remain low for at least a month. He then described a problem that ELBE has been living with since beginning operation, and for which no explanation has yet been found. The problem is that there is an energy drift upward from each of their four cavities when RF is applied, or when the gradient is changed. The time constant is several hours, and it is severe enough that user runs are delayed until the drift stabilized. He described many tests they've made to identify the problem, and although they seemed complete the mystery remains. The session participants were not able to suggest anything reasonable that hadn't already been tried. Fig. 8 shows an example of the energy drift due to two of their cavities.

The cavity session showed that good progress has been made on basic SRF cavity designs optimized for ERL applications. More specifically, the high current cavities of BNL (5-cell, 704 MHz) and JLab (1-cell, 750 MHz) and 5-cell, 1.5 GHz) have been qualified. KEK, Cornell, 4GLS, BESSY, and LBNL each showed their own version of an "ERL optimized" TESLA cavity/module. Presumably each lab has different optimization criteria! However, the KEK 9-cell version with its 600 mA, 5 GeV BBU limit is especially impressive. (The limit with a 1 MHz HOM scatter imposed is 1.5 A single loop and 300mA in 2 loops!)

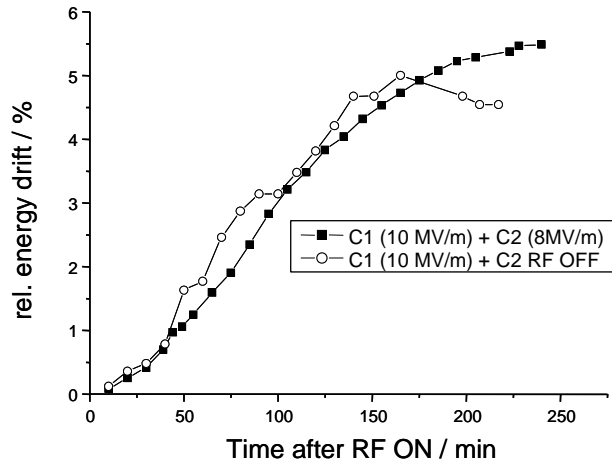

- Beam energy drifts up over hours after switching RF on
- Monday morning user run start-up is delayed
- Energy drift depends on gradient
- Unstable beam energy after each energy change

Fig. 8: ELBE cavity energy drift with time

SESSION 3: TUNERS, MICROPHONICS, AND RF CONTROL

This session had five speakers scheduled:

- Selection of Loaded-Q Values for SRF Cavities Used in Energy Recovered Linacs. Tom Powers (JLab)
- Concept of Vector-Sum Control for CW-operation Christian Schmidt (DESY)
- Measurement and compensation of microphonics in CW operated TESLA-type cavities Oliver Kugeler (BESSY)
- Microphonics Measurements at ELBE Gerald Staats (ELBE)
- Energy recovery linac gradient and phase tolerance calculations Nick Sereno (ANL)

The session began with Tom Powers [6] reminding the audience of the fundamental equations determining, for instance, the necessary klystron power as a function of cavity fields, beam current, shunt impedance, coupling factor, loaded Q, and the phase of the beam relative to the cavity field. He pointed out that in an ERL with perfect recovery, there is indeed no beam loading and structures can be imagined to run at high loaded Qs-as many in the community do seem to be planning to do. He went on to discuss why imperfect energy recovery, with the second pass beam not 180° out of phase with the first beam, is often the case and he described some of the consequences of this. FELs are particularly likely to be designed to run in this state, and other machines may well find themselves drifting into it unintentionally. The obvious consequence of imperfect energy recovery is a need for larger RF power than might have been imagined, and if Q_L is too

high, the increased power could be quite large. Much less obvious is that the loading current resulting from the sum of the two beams is nearly 90° out of phase with the cavity field and thus results in a large reactive power. This can be corrected by tuning, but the transient need for RF power will still exist. Solutions to the problems exist, but the lesson is that care must be taken when designing a machine, selecting QL, and specifying the RF source and coupler capabilities.

The second talk of the session, by Christian Schmidt [7], concerned the important issue of vector-sum control of a string of N cavities, allowing them to be powered as a unit by a single high power RF source and LLRF system rather than by N low power sources and LLRF systems. As the cost of an RF system scales $\sim \text{power}^{1/2}$, substantial cost savings could be possible. He showed the results of simulations looking at a string of 8 cavities fed by one source, with a statistical distribution of microphonic amplitudes and frequencies of each of the cavities. One result, which was initially surprising to most of the audience, showed that if (N-1) cavities vibrate identically and synchronously, and the Nth cavity is free of microphonics, then the vector-sum control loop keeps the beam voltage constant primarily by modulating the amplitude of the Nth cavity by a large amount rather than correcting the (N-1) cavities by a smaller amount (Fig. 9). On the whole, the results looked very promising and the idea certainly merits further study.

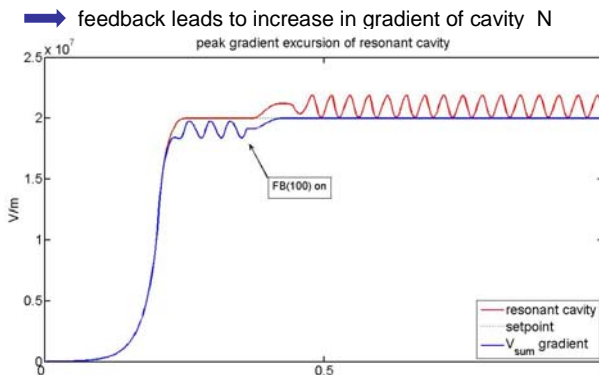

Fig. 9: Example of the Nth cavity response when (N-1) cavities have a coherent microphonic response to a single frequency.

Oliver Kugeler reported on measurements of microphonics in TESLA like cavities and on the results of tests to compensate them [8]. Such compensation will be critical if the possibility of operating at high Q_L s is to be realized. They tested both the Saclay I and II tuners, each of which contain a piezo-actuator for rapid adjustments and a slower stepping motor for wider adjustment. Microphonics were characterized and compensated using pure feedback for low frequency drifts caused by the cryogenic system up to 1 Hz and a feed-forward algorithm for de-excitation of mechanical resonances of the cavity-tank-tuner system above 1 Hz. Fig. 10 shows the dramatic

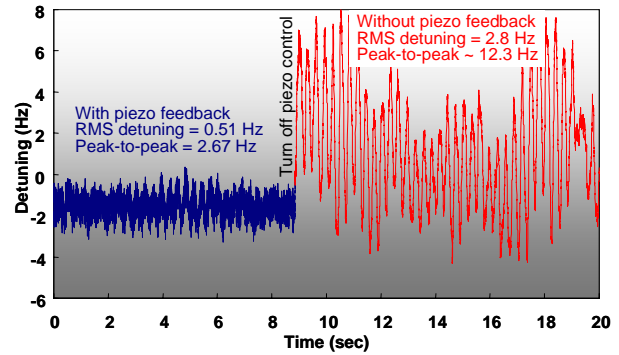

Fig. 10: Feedback compensation of fluctuations in the liquid He bath. The plot shows the behavior of the phase error signal upturning OFF the feedback piezo compensation, leading to phase fluctuations correlated to the He pressure.

reduction of the effects of cryogenic noise after switching on the feedback compensation.

Gerald Staats [9] reported on a detailed series of microphonics measurements at ELBE. They measured noise in the phase controller signal and from a phase independent cavity resonance monitor. In addition, they measured cavity mechanical resonances by Lorentz-force excitation obtained by amplitude modulating the cavity field. Finally, they used geophones for determining the sources of microphonic excitations. A significant finding for their facility, and perhaps others with similar cryomodules, is that phase noise is fairly flat with field level until 8-9 MeV/m at which point it begins rising rapidly in all four of their cavities (see Fig. 11). It is presumed that this is a result of increased LHe boiling. The two cavities in the cryomodule farther from the LHe source have about $1/10^{\text{th}}$ the noise of the other module. Just why this should be isn't entirely clear. The mechanical resonances of all the cavities are similar, and the fact that these are different from those calculated [10] for a single cavity without housing is taken as evidence

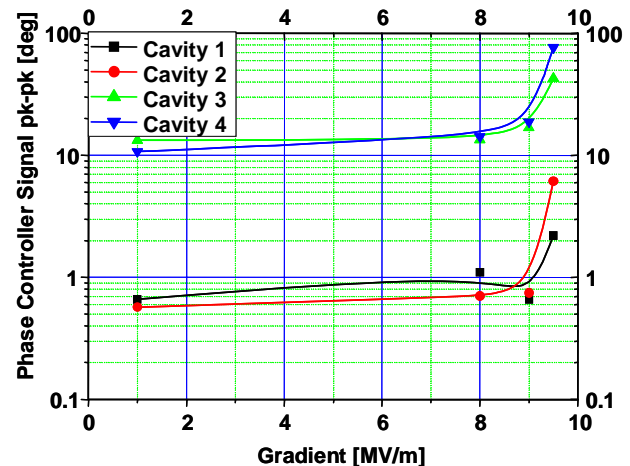

Fig. 11: Peak-peak value of the phase controller signal measured over 10 minutes. The rms values are a factor of 10 lower. (Divide by the loop gain of 70 for the phase detector signal.)

that there is mechanical coupling between the two cavities in a single cryomodule. The major microphonic excitation sources they were able to identify were the He compressors, the water coolant pumps and the air conditioning systems. They emphasize that all of these sources have most of their energy concentrated in the 10-100Hz range, thus it would be desirable for cavity and cryomodule systems to avoid resonances in this range.

The final talk of the session was delivered by Sereno who was concerned with the effects of random energy and phase jitter in a long string of accelerating cavities on the effective beam energy spread of the final beam. The specific question he addressed was how large could the fluctuations be without degrading the beam quality for users or for energy recovery as far as the APS ERL conceptual machine design is concerned. The result of monte-carlo simulations is that it is desired that the effective energy spread increase above the natural energy spread of the user beam at 7 GeV ($\sigma = 0.018\%$), then $\sigma_{\Delta\phi} < 2^\circ$ for phase errors and $\sigma_{\Delta V}/V_0 < 0.2\%$ for gradient errors. These tolerances imply $< 12\%$ effective energy spread for the energy recovered beam at 10 MeV ($\sigma = 6.8\%$). As the test of the Cornell digital control system at the JLab FEL [11] reported $\sigma_{\Delta\phi} \sim 0.02^\circ$ for phase errors and $\sigma_{\Delta V}/V_0 \sim 0.01\%$, it would appear that uncorrelated fluctuations will not be an issue. The next step is to extend the calculations to include cavity dynamics which will provide a correlation between the gradient and phase fluctuations.

SESSION 4: RF SOURCES & COUPLERS (JOINT WITH WG1-INJECTORS)

The session on RF Sources and Couplers had three speakers on the agenda, followed by a joint session with the injector working group (WG1).

- Review of RF Sources Mike Dykes (Daresbury)
- Review of RF Couplers Carl Beard (Daresbury)
- Design of the input coupler for the ERL main linac in Japan Hiroshi Sakai (Univ. of Tokyo)
- Status of the BNL DESY hybrid photoinjector John Smedley (BNL)
- Status of the SRF photoinjector development Jochen Teichert (FZDR)
- Status of the BNL 703 MHz photoinjector Andrew Burrill (BNL)

The session opened with a review by Dykes of the status of RF sources appropriate for ERLs. He reported that RF power sources are proliferating at frequencies and power levels of use. For the injector, MW klystrons and 100kW IOTs are available in the UHF, and 150kW klystrons and >100kW (proposed) IOTs at L-band. If higher powers are needed, sources can be combined. For the main linac, klystrons and IOTs are available in the UHF and at L-band. Solid state amplifiers are generally

low power and quite expensive. IOT vendors are confident that they can optimize designs anywhere from 500 MHz or below up to 1.5 GHz and klystrons can still be built for higher powers or higher frequencies (such as harmonic cavities). IOTs from several vendors are now in the field getting operational experience. Recent work at Lancaster has demonstrated phase stabilization of magnetrons that might be attractive for some applications. Turn-key IOT based transmitters are now available or planned from several vendors. RF sources and power supplies with good efficiency at low power and the capability of high-power transient response can be imagined.

Beard summarized the state of RF couplers in use or being developed by the ERL community. He pointed out that although the requirements for a coupler are not complicated (passive device to transfer power from a source to a load with optimized reflection; a warm or cold window to hermetically seal the interior of a cavity; a (additional?) window to separate atmosphere from vacuum; act as a thermal bridge between ambient and cryogenic temperatures; provide appropriate coupling for different operating modes), virtually every group working on SRF has or is developing their own coupler. The reason is likely that people and groups tend to work with whatever they are familiar. Several groups are working to make the TESLA type coupler work for modest CW power (e.g. the Cornell injector coupler). Some proponents still desire adjustability and cold windows even though the simpler expedient of Q_{ext} adjustment via stub tuners or iris plates outside the cryomodule has been demonstrated over at least one order of magnitude for both waveguide and coaxial couplers. MW class couplers with warm windows have been demonstrated at low frequencies.

The third talk, by Sakai [4], provided an example of a coupler under development for the main linac of the ERL in Japan. The presentation included many details and specifications of the design as well as thermal analysis and a schedule for testing. Fig. 12 summarizes many of the highlights.

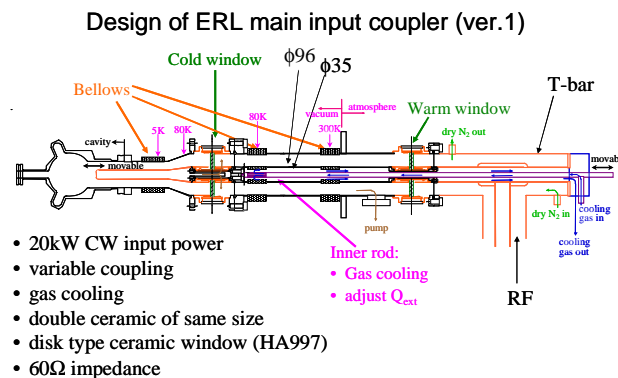

Fig. 12: Version 1 input coupler for the ERL main linac in Japan

At this point WG1, the working group on injectors, joined the session. As the talks in this joint session (Smedley [12], Teichert[13], Burrill) are described in the WG1 summary [14], they will not be included here.

SESSION 5: SRF AND BEAM OPTICS (JOINT WITH WG2-OPTICS)

The session on RF Sources and Couplers was held jointly with WG1 (optics) and had 7 speakers scheduled:

- Suppression of the quadrupole mode BBU by using the eccentric fluted beam pipe Hiroshi Sakai (Univ. of Tokyo)
- HOM Damping Simulation and Measurement of JLab Ampere Class Cavity Haipeng Wang (JLab)
- Coupler-kick emittance increase for ultra low emittance beams in linacs Georg Hoffstaetter (Cornell)
- ERL-related HOM measurements at ELBE Graeme Burt (Lancaster)
- Dual-axis Energy Recovery Linac Chun-Xi Wang (ANL)
- Analysis of HOM-BBU with newly designed cavities Ryoichi Hajima (JAEA)
- 4GLS Cavity Considerations for BBU Emma Wooldridge (Daresbury)

As the presentations by H. Wang, Hoffstaetter, Hajima [15], and Wooldridge [16] are described in the WG2 summary [17], they will not be included here.

The presentation on quadrupole HOM suppression through the use of an eccentrically fluted beam pipe by Sakai [4] was received by enthusiasm, both because of the concept and because of the implications. The idea is that by using two eccentric flutes on the beam pipes at one end of the cavity the quadrupole modes can be converted to dipole modes which will then propagate to the HOM coupler. (The flutes can be seen on the left end of the cavity in fig. 7.) The presentation described an extensive set of flute parameters simulated (angle between flutes, shift from center, length, width...) and showed good comparison between calculation and low measurement. As mentioned in the section on Session 2, their BBU simulations on the KEK-ERL model-2 cavity indicate that a 5 GeV ERL with these cavities would have a BBU

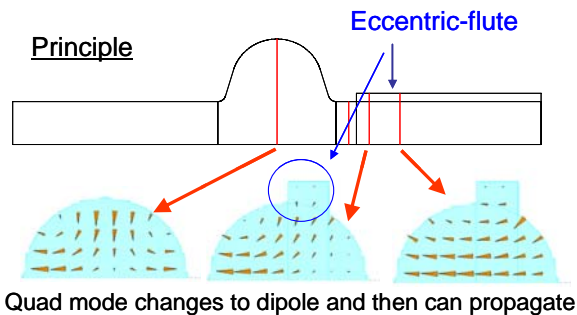

Fig. 13: Basic idea of the eccentric flute

threshold of 0.6 A in a single loop configuration, and even in a two loop ERL the threshold would be 0.3 A. This suggests that 2-loop systems be seriously considered as cost and space saving configurations. Fig 13 shows the basic idea of the eccentric flute.

G. Burt [18] presented some of the results of extensive HOM measurements made on the TESLA-like cavities at ELBE. The measurements were in reasonable agreement with simulation, but the determination of dipole mode centers made by measuring the mode power vs. transverse position showed that the electrical centers of different modes are offset from one another by several hundreds of microns. This will not likely have an impact on regenerative BBU, but could signify a problem with cumulative BBU in long machines. It may also complicate the use of accelerator cavity dipole modes as BPMs. Fig. 14 shows one set of power vs. vertical offset measurements. The electrical center offsets are apparent.

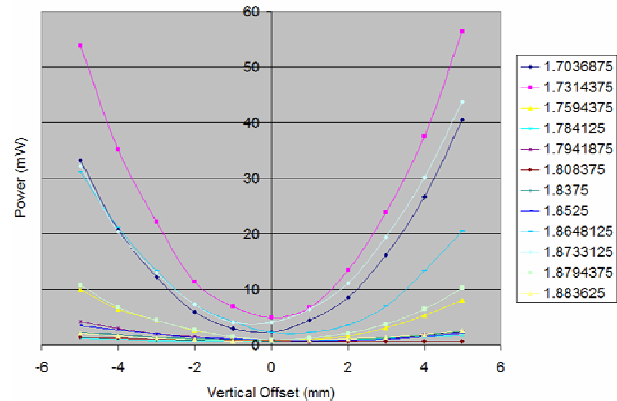

Fig 14: Power vs. vertical offset for 10 dipole modes.

The general feeling on BBU and HOMs was that BBU codes and cavity damping simulations have been benchmarked against experiment so that we now have confidence that 100 mA and even Ampere-class machines can be designed to be stable - possibly even in multi orbit configurations. Further, cavities with strong HOM damping have been demonstrated in simulation and in bench tests. The first of these are now being prototyped and tested in Nb. Waveguide and beam-pipe HOM dampers both show good potential for use with high beam currents. There are some problems with TESLA type HOM couplers in CW operation, but with modifications to their feedthroughs and improved cooling they may be suitable for lower currents.

The final presentation to be discussed here was made by C.-X. Wang [19] who gave the session some of his early thoughts on the idea of dual-axis ERLs. His concept centered on a cavity of the sort depicted in Fig. 15, which can clearly be imagined as two TM010 mode cavities placed side by side with part of the separating wall cut away so that the two cavities are coupled. The possibilities that can be explored with this cavity concept are limitless since there are basically two independent beamlines. Ideas that come to mind immediately are very low energy injection and/or dump energy, flexibility in

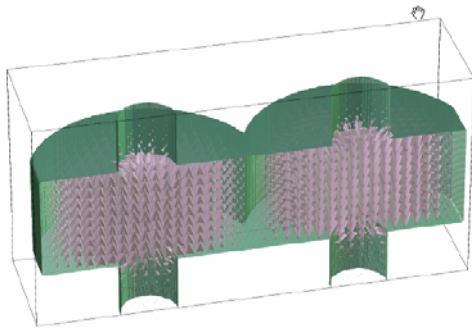

Fig 15: Dual-axis cavity model

design with independent beam optics for the two axes, flexibility in operation... Of course these possibilities come with a price. A linac made of dual axis cavities is only marginally different from two side by side linacs as far as RF losses and refrigeration losses are concerned. Furthermore, in the present concept it would seem likely that dipole kicks from the asymmetric nature of the fields might be an issue. None-the-less, it's refreshing to see new ideas explored. It's not hard to think of applications in which the benefits would be worth the cost.

CONCLUSION

ERL 07 was as successful as ERL 05. In WG3 alone there were 27 talks, including those in the combined sessions with WG1 and WG2. The presentations were all well prepared and described significant progress in project plans, work on outstanding problems, or exciting new ideas and concepts. The sessions were scheduled so that there were more than 10 hours available for the many lively discussions that were stimulated by the talks. Of the presentations, three seem to stand out. One was about the vigorous collaboration led by Daresbury involving Cornell, FZD-Rossendorf LBL, and Stanford. These laboratories are combining resources to solve problems of mutual interest that would seriously stretch the resources of the individual institutions. This collaboration should serve as a model for future groups. Another was the talk by Tom Powers drawing attention to the difficulties of achieving truly 100% energy recovery, the problem of

transients in ERLs, and some of the resulting practical implications for being able to operate an ERL at very high loaded Q 's. The last was the work on the HOM damping scheme for the 9-cell cavity being developed for the main linac of the 5 GeV ERL in Japan. Calculations for this cavity indicate that not only will it be stable against BBU at over 600 mA in a single loop ERL, but it should operate at 300 mA in a two loop ERL configuration. As a two loop ERL is likely to be significantly less costly than a single loop machine, this option now has to be seriously considered.

REFERENCES:

- [1] M. Tigner, *Nuovo Cimento* 37 (1965) 1228
- [2] M. Liepe and J. Knobloch, *NIMA* 557 (2006) 354.
- [3] A. Nassiri These Proceedings
- [4] H. Sakai, T. Furuya, et al, "Development of a 1.3 GHz 9-cell superconducting cavity for the Energy Recovery Linac", These Proceedings
- [5] P. Michel, These proceedings
- [6] T. Powers, These proceedings
- [7] C. Schmidt, These proceedings
- [8] O. Kugeler, These proceedings
- [9] G. Staats, These proceedings
- [10] T. Schlicher, "Vector Sum Control of Pulsed Accelerating Fields in Lorentz Force Detuned Superconducting Cavities", PhD Thesis, DESY, Hamburg, August 1998
- [11] M. Liepe, et al. "Pushing the Limits: RF Field Control at High Loaded Q ", Proceedings PAC 2005.
- [12] J. Smedley, These proceedings
- [13] J. Teichert, These proceedings
- [14] A. Burrill and M. Poelker, These proceedings
- [15] R. Hajima, These proceedings
- [16] E. Wooldrige, These proceedings
- [17] R. Hajima and H. Owen, These proceedings
- [18] G. Burt, These proceedings
- [19] C-X Wang, These proceedings