

## BEAM INSTRUMENTATION FOR KEK ERL TEST FACILITY

K. Furukawa, K. Haga, S. Hiramatsu, T. Kasuga, T. Mitsuhashi, T. Naito, T. Obina, M. Satoh, M. Tadano and M. Tobiya<sup>#</sup>, KEK, 1-1 Oho, Tsukuba 305-0801, Japan  
N. Nakamura, ISSP, Tokyo University, 5-1-5 Kashiwanoha, Kashiwa, Chiba 277-8581, Japan

### Abstract

A test facility to establish the functions of ERL has been planned at KEK. Designs and development of beam instrumentation for the ERL test facility have started under the collaboration of several laboratories in Japan. To examine the beam response from the beam monitor devices using a short bunch length beam, we have constructed a test beam line near the injection point of KEK-PF. The present status of the design and the development of beam instrumentation are described.

### INTRODUCTION

Synchrotron light from the Energy Recovery Linac (ERL) has many outstanding features compared to an ordinary light source, especially with its extremely low emittance and the possibility of ultra-short bunch length. The KEK is planning to construct a hard X-ray ERL facility with arc energy of around 5 GeV under a Japanese ERL collaboration for the fourth generation light source [1,2]. However, there are many key components, such as DC photocathode gun, 1.3 GHz drive laser, superconducting accelerating cavities including cryomodules and cryosystems, to be established before starting the

construction of a full-scale facility. The beam instrumentation is also very important.

Construction of a test facility with arc energy of around 60 MeV to 200 MeV is planned to perform R&D works and beam studies [3]. With this test facility, we will identify the critical components under beam operations, generation and acceleration of the ultra-low emittance beam, and/or short bunch length beam. Commissioning of the test facility will also help to understand the accelerator physics issues. The design parameters of the test ERL accelerator are listed in Table 1.

Table 1 Main parameters of the KEK ERL test accelerator

Parameters	
Injection Energy	5 MeV (10-15MeV)
Injector beam power	500kW (1MW)
Beam energy in arcs	~60MeV(160-200MeV)
SC cavities	9 cells x 4: single module
Normalized emittance	1 mm mrad (0.1mm mrad)
Beam Current	10mA – 100mA
RMS bunch length	1~2ps (0.1ps)

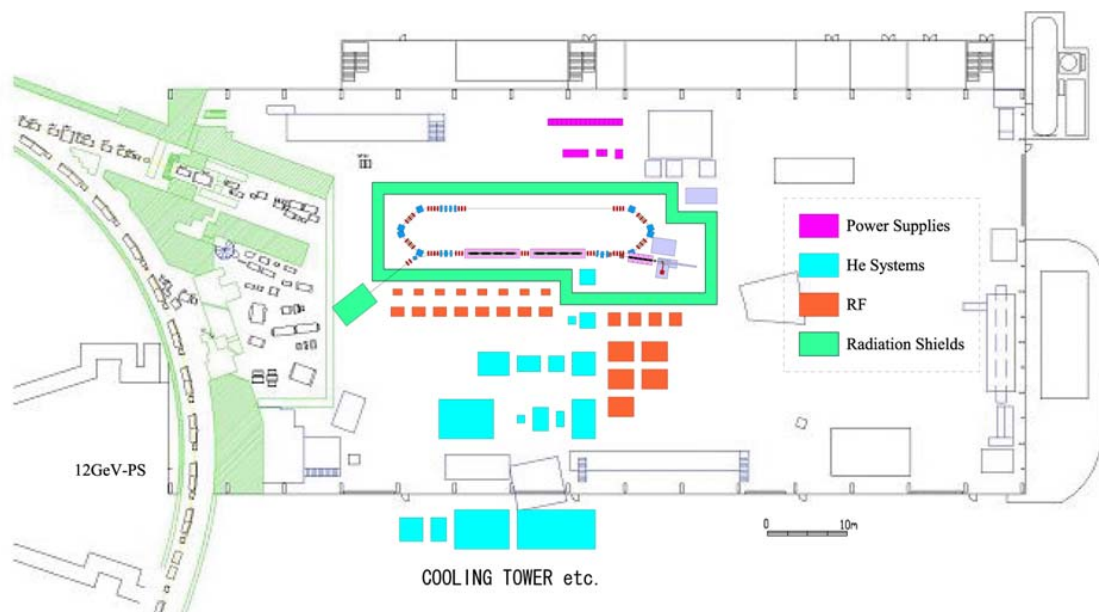

Figure 1 Arrangement plan of KEK ERL test facility in PS-East experimental hall.

<sup>#</sup>makoto.tobiya@kek.jp

To design the necessary beam instrumentation for the ERL accelerator, we have recently formed an ERL beam instrumentation team under several laboratories in Japan. Our missions are 1) to develop the beam monitors for ERL and 2) to develop the control systems including femto-second timing technology. Figure 1 shows the arrangement plan of the KEK-ERL test facility. In the early stage of commissioning, we will keep the long straight section the opposite side of the cavity section for the beam instrumentation test port.

### PRESENT STATUS OF DEVELOPMENT OF BEAM INSTRUMENTATIONS

#### Test beam line for short beam at PF-BT

We have constructed a test beam line near the injection point of the KEK PF ring for the developments of beam instrumentation using a short pulsed beam from the linac of beam energy 2.5 GeV. By tuning R56 and T566 of the beam transport line, we will be able to obtain a very short beam with the bunch length of 0.17 mm (0.57 ps). Figure 2 shows a photograph of the constructed test beam line.

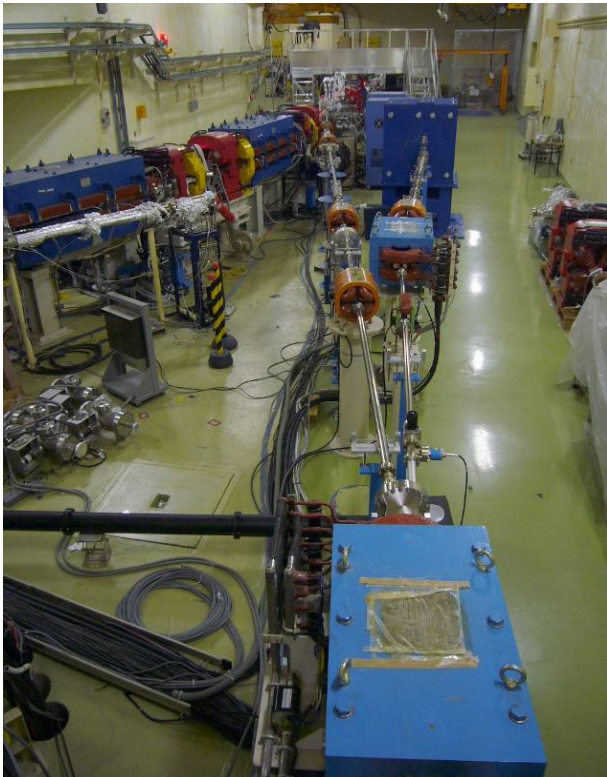

Figure 2 Test beam line (to the right) near PF injection point.

From autumn 2007 runs, we will start the simultaneous injection scheme between the KEKB HER ring and the KEK PF ring using a fast switching bending magnet [4]. We will be able to use the beam freely with the maximum repetition rate of around 25Hz for the test line.

#### SR related monitors

We have been developing the SR related monitors such as an optical phase space monitor, bunch length monitor using intensity interferometry, input optics system with all reflective-optics for femto-second streak camera, and beam halo monitor by means of coronagraph [5]. An example of the beam halo images obtained by coronagraph during single bunch operation of the PF ring is shown in Fig. 3. We can see clearly beam halo of order of about  $10^{-7}$  of main beam.

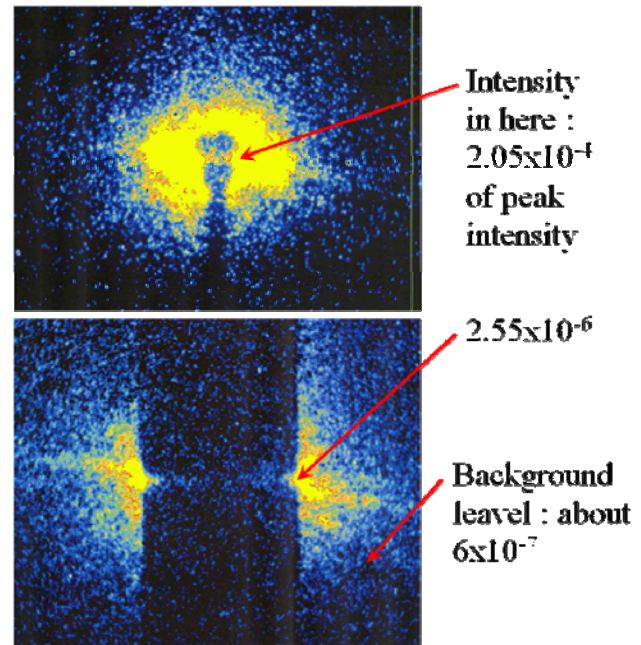

Figure 3 Observation of beam halo. Upper: near center (CCD exposure time of 3ms). Lower: far tail (exposure time 100ms).

#### Beam position monitors

In the acceleration section, two beams (beam under acceleration and deceleration) may pass within a very short time interval ( $\sim 0.38$ ns). Since the two beams can naturally take different orbits, it is necessary to measure the two orbits simultaneously and independently. One idea is to develop a BPM electrode with very good time response, and gate the output with good signal isolation. To achieve very good time response, we have developed the glass-type sealed feedthrough with smaller relative permittivity ( $\epsilon_r \sim 4$ ) than normal alumina-ceramic types ( $\epsilon_r \sim 10$ ). Also we can reduce the beam response to within 0.4 ns by improving the button structure. A result of simulation using GdfidL is shown in Fig. 4. To investigate the performance of the feedthroughs, we fabricated several kinds of BPM electrodes with different seal materials (different permittivity) and seal structures. They will be installed in the test beam line at PF-BT to measure the beam responses.

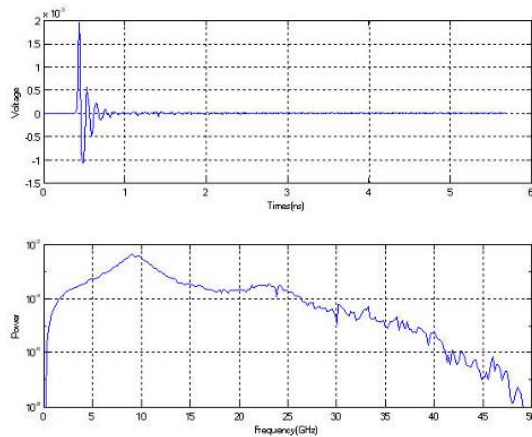

Figure 4 Simulated beam response, using GdfidL, of a glass-sealed BPM with its frequency response. The bunch length was 3mm in this case.

### *iGp for full-speed bunch-by-bunch position detection*

We have been collaborating with SLAC and INFN-LNF to develop a next generation feedback signal processor system under the support of a US-Japan collaboration in High Energy Physics. As a first stage, we have developed a simple signal processor (iGp system) [6]. It consists of a fast ADC (MAX108), a fast and dense FPGA (Vertex2 XC2V6000) and a fast DAC (MAX5889) as shown in the block diagram of Fig. 5. A photograph is shown in Fig. 6.

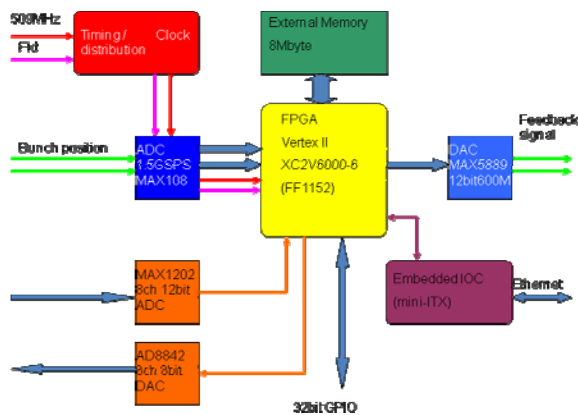

Figure 5 Block diagram of iGp feedback processor.

The KEKB iGp systems have been confirmed to work up to 560 MHz with simple FPGA firmware. This limitation comes from the scattering in delays of the output timings of the FPGA to the high speed DAC. The ADC and input of FPGA (and memory) seems to work with higher frequency. In fact, it is already confirmed that the

test set of MAX104 (1GSPS) and Spartan-3 FPGA works up to 1GHz of master clock. We expect the present iGp system might be able to record the bunch position with clock rate of 1.3GHz. A detailed study will be made soon.

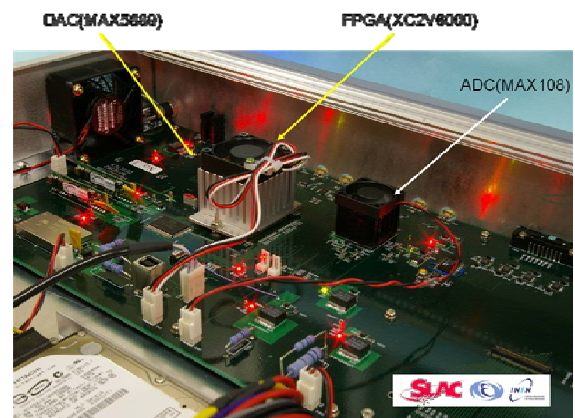

Figure 6 Photo of iGp feedback processor.

## SUMMARY

We have started the design and the development of the beam instrumentation of KEK-ERL test facility under collaboration of several laboratories and institutes. Using the existing accelerators such as KEK-PF and KEKB, several instruments such as beam position monitors, SR related monitors, have already been studied. To examine the beam response of the instruments, we have constructed a test beam line for short pulse beam at the end of PF-BT. We plan to install BPMs and SR related monitors soon.

We thank ERL Project Office of KEK for the continuous support. Members of KEK ERL project are acknowledged for numerous thoughtful discussions.

## REFERENCES

- [1] T. Kasuga *et al.*, APAC07, TUPMA046.
- [2] T. Kasuga *et al.*, "Status of R&D Efforts Toward the ERL-based Future Light Source in Japan", to be presented at PAC07.
- [3] S.Sakanaka *et al.*, "Lattice design of the test ERL in Japan" in these proceedings.
- [4] M.Satoh *et al.*, "The KEK injector upgrade for the fast beam-mode switch", in proceedings of EPAC2006, Edinburgh, Scotland, 2006.
- [5] T.Mitsuhashi, "Beam halo observation by coronagraph", in proceedings of DIPAC2005, Lyon, France, 2005.
- [6] D.Teytelnam, *et al.*, "Design and testing of Gproto bunch-by-bunch signal processor", in proceedings of EPAC2006, Edinburgh, Scotland, 2006.