

# RF LINERS FOR HIGH BRILLIANCE BEAM

Nelly Rouvière, ESRF, Grenoble, France  
on behalf of the Vacuum Group

## ABSTRACT

High brilliance storage rings may be limited in their performances by the gas desorption produced by high temperatures reached on the RF liners shielding the beam from bellow corrugations. One straight section is available at the ESRF to carry out tests of various geometries of RF liners. The 16 bunch filling mode, 6mA per bunch is currently used to measure the temperature increase of different types of RF liners developed at ESRF, LEP, APS and STANFORD. The results of these models will be described and analysed in this paper.

## 1 INTRODUCTION

The ESRF is a Synchrotron Radiation machine of 844 m in circumference. The dimensions of the octagonal vacuum chambers are 79mm x 33mm. About 288 bellows are distributed all around the machine. The vacuum bellows absorb thermal expansion of the beam tube during beam operation and baking (up to 2 cm). The bellows also provide the necessary working space for connecting beam tubes as well as some tolerances for mis-alignment ( $\pm 5$ mm). The vacuum bellows are assembled with RF shields. The RF shields screen corrugations of bellows from bunched beams and makes wall current flow smoothly to reduce the excitation of higher order modes (HOM). The RF shield ensures a good electrical contact while allowing mechanical flexibility. In general, the electrical continuity is essential for high frequency current machines (350 Mhz) depending on the bunch mode.

The ESRF is operated in different filling modes : single bunch, 16 bunch, 1/3 filling (330 bunch), hybrid modes. In addition, for values of stored current over 90mA in the 16 bunch mode, bursts of pressure are observed at the location of the RF fingers.

## 2 RF SHIELD USED AT THE ESRF

The usual RF shield is a finger type. Since the construction of the storage ring, two versions of RF fingers have been installed.

### 2.1 First version

The model installed in the bellows sections during the construction of the storage ring was similar to that

installed on LEP - **Figure 1**. The fingers are made of Be/Cu. RF fingers are pressed perpendicularly against a stainless steel sleeve by means of a nimonic spring. The compressing force is about 30g per finger.

In 16 bunch mode, the current is limited to 80mA with a pressure at  $2.10^{-8}$  mbar. For a few contacts the temperature level increases to 150°C. Some pressure bursts occur, in these cases, pressure can reach  $10^{-6}$  mbar. Therefore the compressing force is not constant around the circumference of the sleeve.

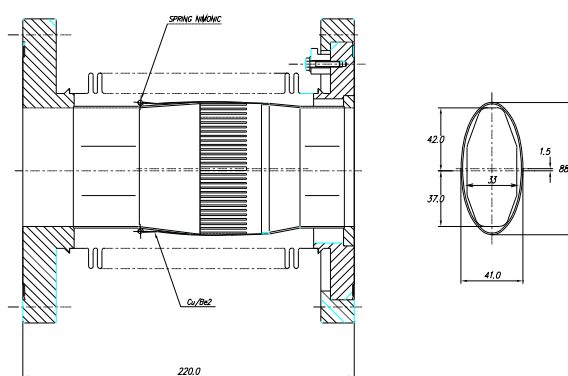

Fig. 1 RF Fingers ESRF - Version 1

### 2.2 Second version (Figure 2)

In the second version two nimonic springs are used. The compressing force increased from 30g to 50g per finger. Tests show that there are still pressure bursts higher than  $10^{-7}$  mbar. In the 16 bunch mode, current is again limited to 80mA with a temperature of 110°C. On several RF fingers pressure burst phenomena are still observed.

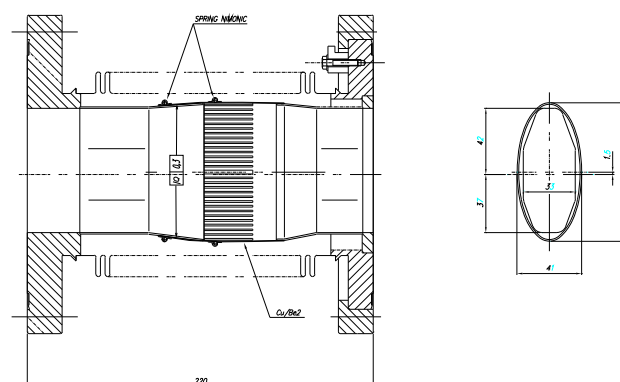

Fig. 2 RF Fingers ESRF - Version 2

In conclusion :

With the octagonal profile of the vessel and its longitudinal and angular movements induced by the bakeout, these versions of RF liners are not suitable, and limit the potential performances of the machine.

### 3 NEW CONCEPT : “METALLIC SOCK”

To obtain a reliable electrical continuity :

- for high frequency currents,
- with the large longitudinal and transversal displacements,
- with a choice of materials compatible with bakeout temperatures of 300°C.

A new concept has then been developed with the metallic mesh. The so-called “the metallic sock”.

#### 3.1 First prototype

The stainless steel mesh is composed of 150 strands of about 0,5mm in diameter and about 130mm in length.

The “metallic sock” is welded at each extremity to the sleeves. The stainless steel / stainless steel connection is made carefully to avoid creating RF cavities (HOMs). **Figure 3** shows the design of this model. Tests of the prototype installed on the machine give a temperature of 180°C for 90mA in the 16 bunch mode.

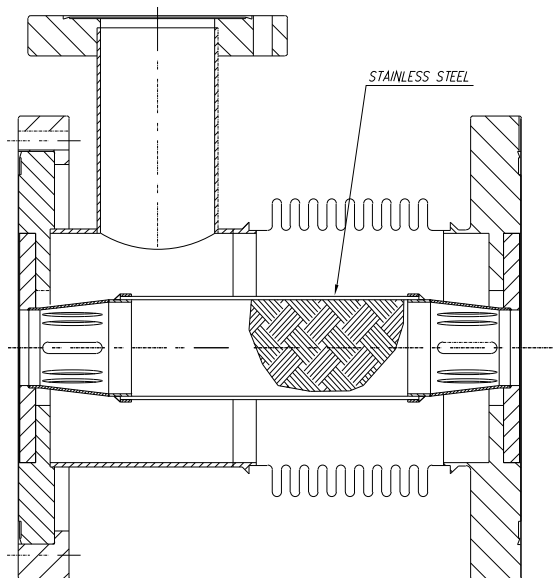

Fig 3 Metallic sock - First prototype

The tests of the first prototype reveal that:

- there are no more pressure burst phenomena,
- temperature increases are directly proportional to current, but are too high. This is probably due to the resistivity of the stainless steel.

#### 3.2 Second prototype

The mechanical characteristics of stainless steel were maintained (bakeout at 300°C) but an attempt was made to reduce the resistivity of the sock, hence the use of copper-plated stainless steel. The copper deposit was about 60µm. The tests of the prototype installed on the Machine give a maximum temperature of 75°C for 90mA.

Copper plating considerably reduced the resistivity of the sock and therefore decreased heating. On the other hand, the copper plating was put on the mesh which was already plaited and thus decreased flexibility. It is therefore necessary to plate the wire before the manufacturing the mesh.

### 4. COLLABORATIONS

The mutual volition to resolve this problem has motivated an interest in setting up a collaboration programme between APS and Stanford. The advantage of the ESRF is that we have the possibility to carry out full tests with 6 GeV stored beam. Here we report the tests performed at the ESRF.

#### 4.1 RF fingers from APS

The collaboration with APS (Justin JONES): APS provided us with one of their RF fingers which was adapted mechanically to the straight sections of the ESRF storage ring.

As seen on **Figure 4**, the geometry is slightly different. A double row of Be/Cu RF fingers is in contact with the vacuum vessel. After being installed on the storage ring, tests show that temperatures of the contacts reach about 140°C in the 16 bunch mode, for a 90mA current. We note that there is no pressure burst.

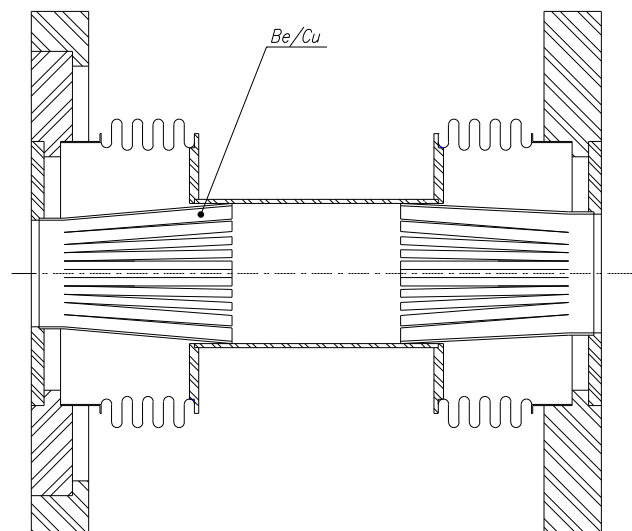

Fig. 4 RF Fingers - APS

#### 4.2 RF fingers from STANFORD (Figure 5)

The collaboration with STANFORD (Nadine KURITA) :

In the frame of this collaboration and with the help of the ESRF Design Office, the STANFORD model was re-designed and then installed on the storage ring.

RF Fingers are made of Glidcop which affords a better mechanical resistance during bakeout. Each stainless steel finger is pressed down by stainless steel springs.

The temperature is 160°C in the 16 bunch mode for 90mA.

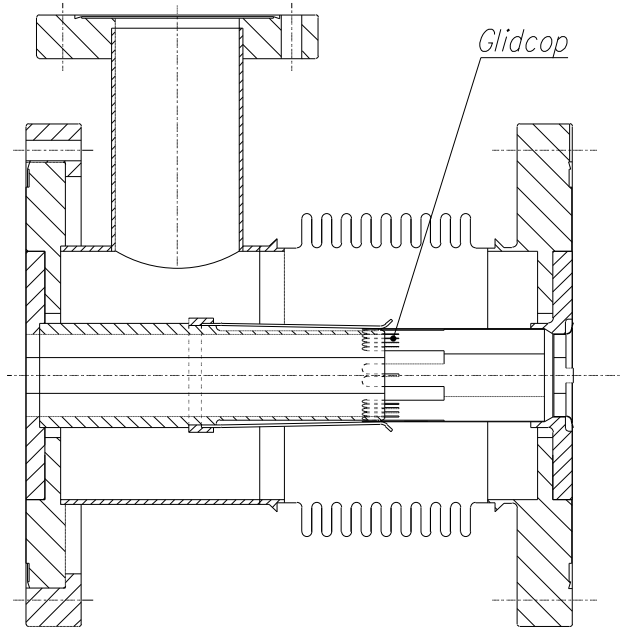

Fig. 5 RF FINGERS - STANFORD

### 5. RESULTS

All the tests are summarised on Figures 6 & 7.

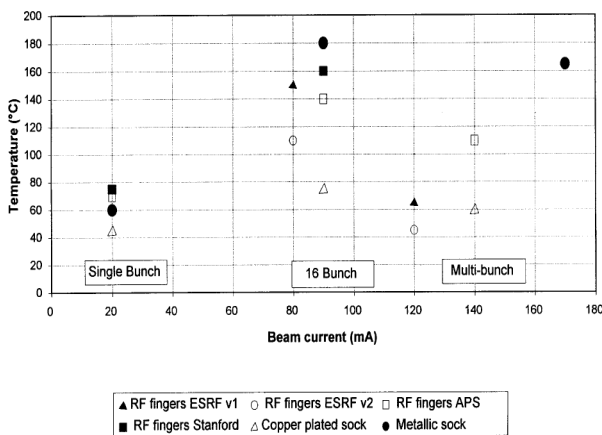

Fig.6 Temperatures versus currents depending on the different modes

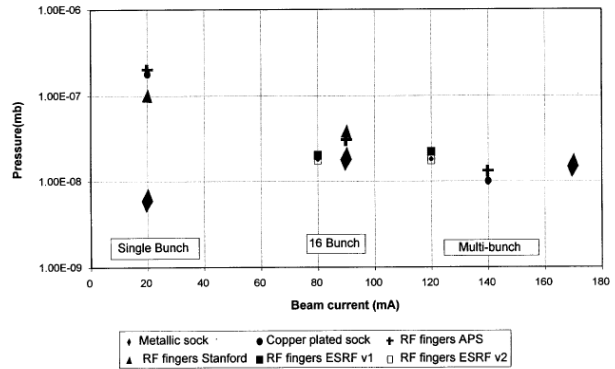

Fig. 7 Pressures versus currents depending on the different modes

The comparative tests of the six RF shield versions show that results of temperatures obtained with the “metallic sock” are encouraging in the different filling modes. However, desorption has to be reduced with a bakeout at 300°C to decrease the pressure.

In September 1996, a new version of this sock made of silver plated stainless steel wire will be tested in an attempt to increase electric conductivity while decreasing the diameter of the wire in stainless steel to increase flexibility.

### 6. CONCLUSION

Applying the “metallic sock principle should enable RF shields to :

- maintain a good electric continuity,
- eliminate the sliding contact which is subject to contact resistor problems,
- withstand important longitudinal and transverse displacements,
- adapt to all geometries of the vessels,
- prohibit the generation of dust from friction on contacts,
- be made of different materials in order to be used on storage rings requiring bakeout at high temperatures (silver plated stainless steel version) or on storage rings with no bakeout (copper version).

Special thanks to

Justin JONES from APS, Nadine KURITA from STANFORD, the LEP Vacuum Group, Bernard PLAN from the ESRF Design Office and the ESRF Vacuum Group.