

SLOW BEAM EXTRACTION SYSTEM OF TARN II

A. Noda, K. Chida, M. Yoshizawa, F. Soga, A. Mizobuchi and Y. Hattori*
 Institute for Nuclear Study, University of Tokyo
 Midori-cho 3-2-1, Tanashi-city, Tokyo 188, Japan

Abstract

Table 1

A slow beam extraction system for TARN II has been constructed to provide heavy-ion beams ($p, \alpha \sim \text{Ne}$) at intermediate energy (150~350 MeV/u). A third order resonance extraction is to be used. Hardware equipments with specifications for ultra-high vacuum ($\sim 10^{-10}$ Torr) are almost completed. According to beam tracking, the emittance of the extracted beam and the extraction efficiency are estimated to be $5\pi \text{ mm} \cdot \text{mrad}$ and more than 89%, respectively.

Introduction

TARN II is a synchrotron/cooler ring for heavy ions up to Ne. Its maximum energies are 1100 MeV and 350 MeV/u for proton and ions with charge to mass ratio of 1/2, respectively.¹ In order to provide heavy ions with intermediate energy for basic study of biomedical irradiation, a slow beam extraction system from TARN II with use of a third order resonance has been designed and constructed. Deliverable beam intensity is $\sim 10^6$ ions per cycle (1 cycle is ~ 8 sec.).

In the present paper, the outline of the slow beam extraction system adopted at TARN II is described at first. Then the results of technical development of equipments for slow extraction are presented. Finally typical results of beam tracking calculations are given together with the expected quality of the extracted beam.

Slow Beam Extraction System

The apparatus for slow beam extraction is shown in Fig. 1 with the layout of TARN II. The extraction procedure is performed in the following sequence.

- (1) In order to assure that all the beams come out from the extraction course without being lost at other parts of the ring, such an orbit bump is made as makes the aperture of the ring to be minimum at the position of the first septum of an electrostatic type (ES), whose septum is located 75 mm outside from the central orbit. The bump orbit is made by exciting three back-leg coils (Bump Coils 1~3 in Fig. 1) in 1 second nearly at the end of acceleration stage, after the beam size is expected to shrink by adiabatic damping.

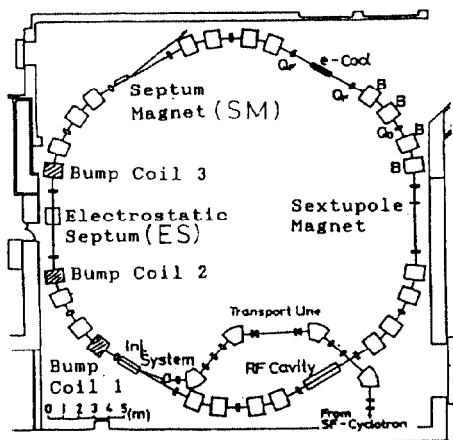

Fig. 1 Layout of TARN II and its slow beam extraction system.

* Hitachi Ltd.

Parameters of Slow Extraction System of TARN II

Ion Species	$p, \alpha \sim \text{Ne}$
Beam Energy	150 ~ 350 MeV/u
Extraction Scheme	Third Order Resonance Extraction (1.6667, 1.80)
Operating Point	75 mm outside from central orbit
Septum Position	Circulating Beam $\leq 50\pi \text{ mm} \cdot \text{mrad}$
Beam Emittance	Extracted Beam $\sim 5\pi \text{ mm} \cdot \text{mrad}$
Momentum Spread	$\pm 0.2\%$

- (2) The operating point at injection is chosen to be around $(Q_H, Q_V) = (1.75, 1.80)$, which is kept also during acceleration. The horizontal tune is shifted toward the resonance, $3Q_H = 5$, with progress of the extraction. Such fine tune adjustment is made by exciting correction coils attached to the lattice quadrupole magnets, while large shift from injection point to (1.68, 1.80) is made by changing the excitation currents in main coils in these magnets.
- (3) Beams which have arrived at unstable fixed points increase in their amplitude and after reaching the the aperture of ES ($x \geq 75$ mm) they are deflected outward as large as 5.8 mrad by a static high voltage.
- (4) The deflected beams by ES are further deflected outward by 85 mrad with a septum magnet (SM), located almost one cell downstream from ES, to be guided outside the ring.

As a resonance exciter, a single sextupole magnet located at the position indicated in Fig. 1 is excited at the level corresponding to the extraction beam energy throughout the whole process from injection to extraction. The injected beam with emittance and momentum spread up to $150\pi \text{ mm} \cdot \text{mrad}$ and $\pm 0.2\%$, respectively, is found to be still bounded and stable even under such rather strong sextupole field, although the emittance ellipse is deformed a little bit.² The main parameters of the slow extraction system described above are listed up in Table 1.

Hardware Development

For the slow extraction described in the previous section, equipments given in Table 2 are needed. Among them, the electric septum (ES) and septum magnet (SM) are described, which have necessity of technical developments peculiar to TARN II with ultra-high vacuum specifications.

Table 2

Hardware Equipments for Slow Beam Extraction	
Sextupole Magnet	$B''L/B\rho = 0.3015 \text{ 1/m}^2$ (DC mode)
Electrostatic Septum	$E = 70 \sim 85 \text{ kV/cm}$, $L = 1.0 \text{ m}$, Deflection Angle = 5.8 mrad, Septum Thickness = 0.15 mm
Septum Magnet	$B = 5 \text{ kG}$, $L = 1.0 \text{ m}$, Deflection Angle = 85.2 mrad, Septum Thickness = 9 mm
Bump Coil 1	Deflection Angle = 5.4 mrad
" 2	" = -7.1 mrad
" 3	" = 7.1 mrad

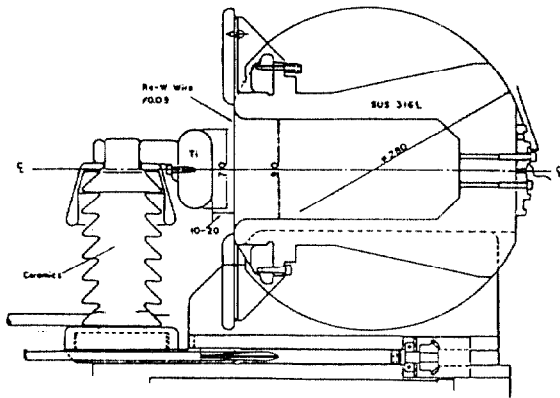

Fig. 2(a) Cross sectional view of the electrostatic septum.

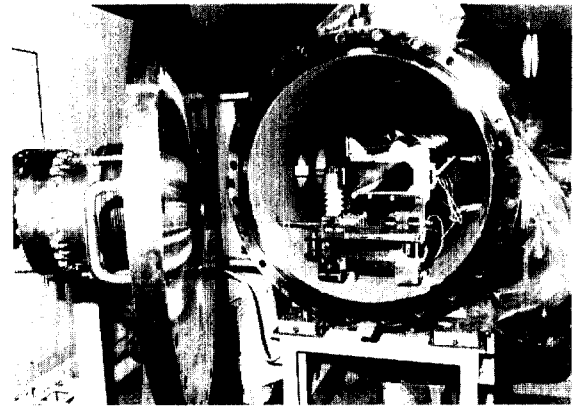

Fig. 2(b) The electrostatic septum installed into its vacuum chamber.

Electrostatic Septum

As the first septum, an electrostatic septum is fabricated. The negative high voltage is applied to an electrode made of Titanium opposing to the earth potential given by wires $90 \mu\text{m}$ in diameter made of Re-W alloy stretched with spacing of 1.25 mm (Fig. 2(a)). Tensions of these wires are adjusted to be 600 g . The driving mechanism to adjust the position of electrode is designed to be oil free and tolerable against baking up to $\sim 300^\circ \text{ C}$. The fabricated electrostatic septum installed into its vacuum vessel is shown in Fig. 2(b). The high voltage up to 85 kV is supplied by a ceramic feed-through, just before which a protection resistance of $200 \text{ k}\Omega$ is attached in order to reduce the charge flow in case of sparking.

Under the vacuum pressure better than a few times 10^{-6} Torr , high voltage test has been safely performed without noticeable leak current. Up to now, even without baking the pressure better than $5 \times 10^{-9} \text{ Torr}$ has already been achieved with evacuation utilizing a turbo-molecular pump and a cryogenic pump of pumping speed of 200 and 800 l/sec , respectively.

Septum Magnet

The septum magnet is fabricated with solid iron block instead of laminated plates assuming DC operation in order to suppress degassing rate. In the present case, magnetic field of 5 kG is required with the septum thickness less than 9 mm .³

The current density at the septum coils amounts to 78 A/mm^2 and cooling of these coils is considered to be a severe problem. However temperature rise at septum coils has been experimentally studied in the air and is found below 30° C for the maximum current.⁴ Although a little bit higher temperature rise is anticipated for

real usage in a vacuum chamber due to lack of convection, it is assured that DC excitation up to full current of 2500 A is well in a range of practical use.

Another item to be paid attention because of DC operation is the size of leakage magnetic field outside the septum coil. Beam with large size just after injection is anticipated to exist at the place very close to the septum coil. Measured field homogeneity in the aperture is better than 0.8% and the leakage field strength outside the septum is less than 0.24% of the field strength in the aperture, which is considered in a tolerable range.⁴

In order to use this septum magnet in TARN II ring, which requires ultra-high vacuum, it is very important to reduce the outgassing rate. Because of ceramic coating and sheets of Kapton used for insulation, we were afraid of large amount of degassing rate. The septum magnet during installation procedure into its vacuum chamber is shown in Fig. 3. However, after baking up to 80° C during 48 hours , the pressure of $2 \times 10^{-9} \text{ Torr}$ has already been achieved with evacuation only by a turbo-molecular pump of pumping speed of 400 l/sec . This rate, we consider, is well applicable in real usage. In Fig. 4, mass spectra before and after the baking are shown. Peaks of H_2O and CO or N_2 are reduced after baking, while some peaks of hydrocarbon increases after baking. This is considered to be due to the presence of some organic materials such as Kapton.

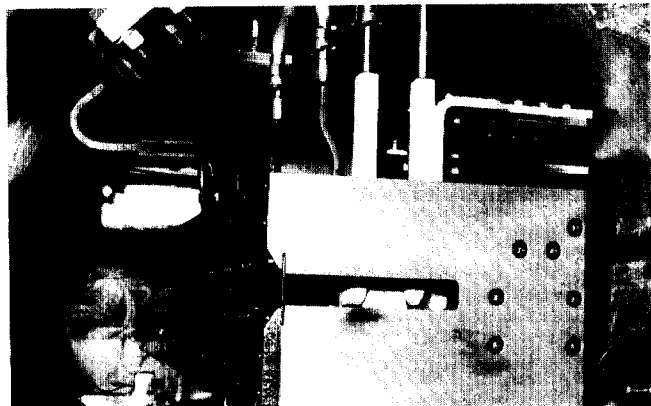

Fig. 3 The septum magnet installed into its vacuum chamber.

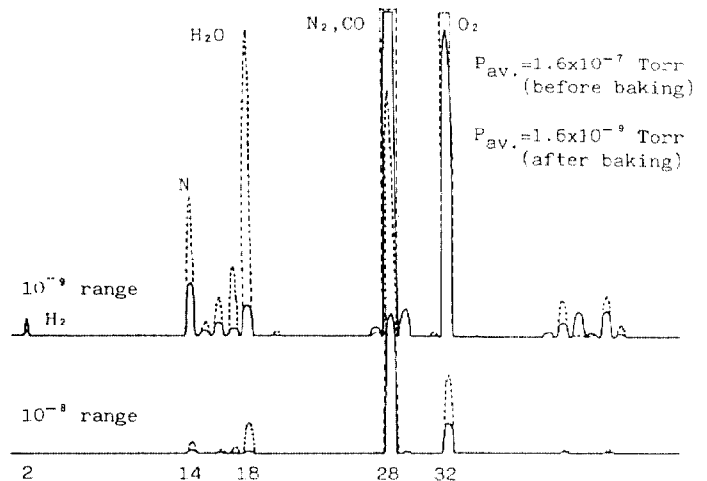

Fig. 4 Mass spectra of the chamber including the septum magnet before (dashed line) and after (solid line) baking at 80° C during 48 hours .

BEAM BEHAVIOUR IN TRANSVERSE PHASE SPACE

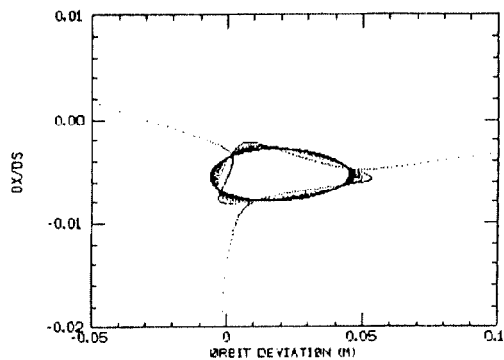

Fig. 5(a) Beam behaviour in the horizontal space at the entrance of ES through the whole process of extraction. Beam with central momentum and emittance of $50 \pi \text{ mm} \cdot \text{mrad}$ is tracked.

LAST THREE TURNS PLUS EXTRACTED BEAM

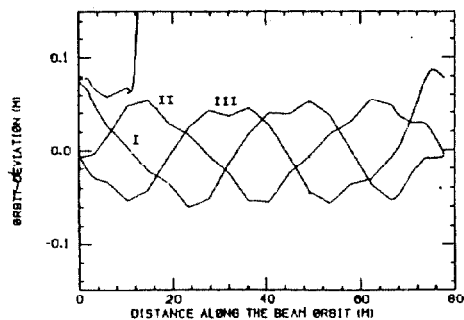

Fig. 5(b) Beam locations over the whole circumference in three turns just before extraction and the extracted beam position.

Beam Tracking during Extraction

At TARN II, the horizontal aperture is basically designed to be $\pm 100 \text{ mm}$, but at some places where electrostatic pick-ups locate, it is limited by much smaller value as $\pm 70 \text{ mm}$. In order to ascertain that ES really makes the available aperture for the circulating beam to be minimum under the presense of the orbit bump above mentioned, it is needed to investigate the beam motion in three turns just before extraction. For this purpose, beam tracking is performed. Beam motion in transverse phase spaces is traced with transfer-matrix formalism. The nonlinear element is treated with thin lens approximation. The beam momentum is kept at a certain value, because no RF voltage is to be applied in the present case during the extraction process. The horizontal tune of the ring is gradually shifted from 1.75 to 1.6667 by changing the field gradients of the quadrupole magnets linearly. In Fig. 5(a), beam behaviour in the horizontal space at the entrance of ES is shown through the whole process for such a beam with central momentum and emittance of $50 \pi \text{ mm} \cdot \text{mrad}$. Beam locations in three turns just before extraction are shown in Fig. 5(b) together with beam position of the extracted beam.

Such a tracking has been performed for various beam condition. In Table 3, expected turn separation and extraction efficiency obtained from these tracking is summarized. In Fig. 6, the beam shape of the extracted beam in the horizontal phase space at the exit of SM is shown, where the high voltage at ES is reduced from 85 kV to 70 kV from the beginning to the end of the extraction process. While the instantaneous

Table 3

Turn Separation and Extraction Efficiency		
Condition of Circulating Beam	Turn Separation(mm)	Extraction Efficiency(%)
Emittance $\Delta p/p$ ($\text{mm} \cdot \text{mrad}$) (%)		
5π 0.2	2.5	94
5π 0.0	4.0	96
5π -0.2	6.3	98
50π 0.2	1.4	89
50π 0.0	2.6	94
50π -0.2	4.2	96

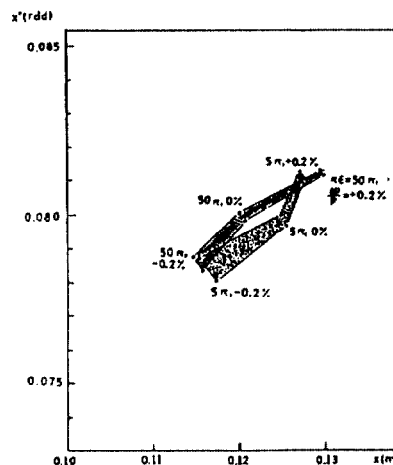

Fig. 6 Beam shape of the extracted beam in the horizontal phase space at the exit of the septum magnet. Values of $\pi \epsilon$ and $\Delta p/p$ present the ones of the circulating beam before extraction.

emittance of the extracted beam is $\sim 2 \pi \text{ mm} \cdot \text{mrad}$, the integrated emittance over the whole extraction process is estimated to be $\sim 5 \pi \text{ mm} \cdot \text{mrad}$.

Acknowledgements

The authors would like to present their sincere thanks to Prof. T. Nakamura at Cyclotron Radioisotope Center, Tohoku University for his continuous encouragement throughout the work. This work was supported by the Grant in Aid for Special Research of Cancer of the Ministry of Education, Science and Culture. The computer calculations were performed with FACOM 780 at the Computer Center of Institute for Nuclear Study.

References

- [1] T. Katayama et al., "Cooler Synchrotron TARN II", Particle Accelerators, Vol.32 (1990) pp. 105-111.
- [2] A. Noda et al., "Slow Beam Extraction from TARN II", Proc. of the 7th Symp. on Accelerator Science and Technology, Osaka (1989), pp. 309-311.
- [3] M. Yoshizawa et al., "DC Septum Magnet for TARN II", Proc. of the 6th Symp. on Accelerator Science and Technology, Tokyo (1987), pp 175-177.
- [4] A. Noda et al., "DC Septum Magnet for Beam Extraction", Proc. of the 1989 Particle Accelerator Conference, Chicago (1989), pp. 363-365.