

SIMULATION AND OPTIMISATION OF A 100 mA DC PHOTO-INJECTOR

F.E. Hannon^{§*}, C. Hernandez-Garcia^{*}

^{*}Thomas Jefferson National Accelerator Facility, Newport News, VA 23606,

[§]Cockcroft Institute, Lancaster University, Bailrigg, Lancaster, LA1 4YW

Abstract

A prototype 100mA injector is presently being designed and manufactured jointly between Thomas Jefferson National Accelerator Facility (JLab) and Advanced Energy Systems (AES). This paper discusses the physics optimisation and performance of the injector which has been studied using the space-charge tracking code ASTRA. The objective is to operate the 7MeV injector with 135pC electron bunches at 748.5MHz repetition rate. We show that the longitudinal and transverse electron bunch properties can be realised within the constraints of the design.

INTRODUCTION

The injector consists of a 500kV DC gun, similar to that used in the JLab FEL facility, followed by an emittance compensation solenoid which focuses the electron beam into a 748.5 MHz SRF cryo-module. The module consists of three single cell cavities that accelerate the beam to ~7MeV and a 3rd harmonic cavity used for imposing some longitudinal linearity and, to some extent, bunching.

The evolution of the early design has been described previously [1][2][3], and recently changes to the component positioning resulted in the requirement for the re-optimisation and simulation recorded in this paper.

It is anticipated that the nominal operating conditions are such that every RF bucket is filled with 135pC electron bunches (~100mA average current). The single cell cryo-module design allows for current scaling to higher bunch charges, with some degradation in the beam properties. Additionally, the relatively low frequency reduces the problems introduced by higher order modes and beam break up.

SYSTEM DESCRIPTION

The schematic layout of the injector is shown in Figure 1. The layout principle was to keep the length as short as possible to counteract the effects of space charge blow up.

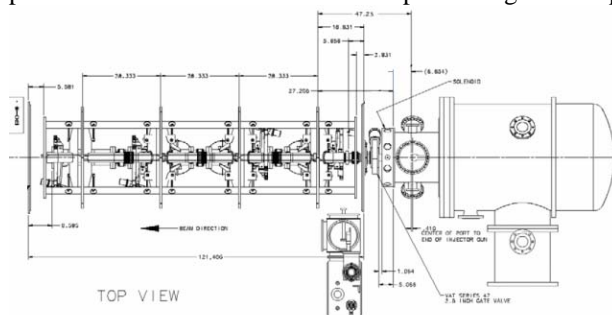

Figure 1: Schematic View of the Injector Layout.

The first iteration of modelling was performed using the space charge tracking code ASTRA [4], where the injector is assumed to be axially symmetric. The on-axis field maps for each of the components were generated using either POISSON or SUPERFISH and used as input for ASTRA. The superimposed normalised field maps as a function of longitudinal position are shown in Figure 2.

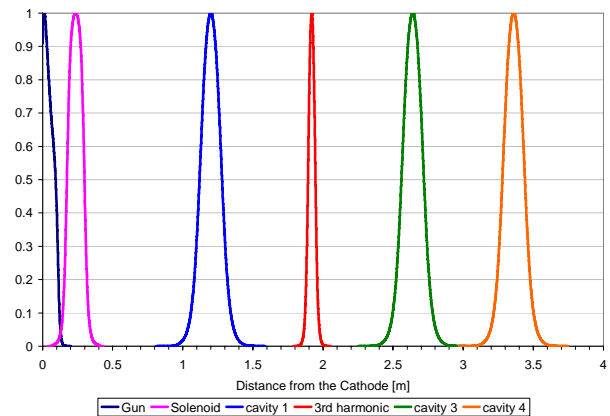

Figure 2: Normalised On-axis Field Maps as a Function of Distance from the Cathode (colour).

The optimisation philosophy was to achieve small transverse and longitudinal emittances at the end of the injector and to try and preserve a linear energy chirp along the bunch length to allow for further bunch compression in an injection chicane.

The electron bunch properties at the cathode depend mainly on the cathode and laser parameters. The DC gun will operate with a caesiated GaAs photo-cathode. If short laser pulses are used (<10ps) it is thought that the long decay time of GaAs will dominate the bunch length profile [5]. A longitudinal, Gaussian distribution with an rms length of 20ps has therefore been assumed for modelling purposes as the response features of the GaAs should be smeared by the length of the bunch. Transversely the profile is top-hat, and has been assumed to have a 5mm diameter (rms 1.25mm).

ASTRA RESULTS

Inside the gun cavity the electron bunch immediately expands both transversely and longitudinally under space-charge forces. The solenoid directly after the gun focuses the bunch transversely into the first accelerating cavity, whilst longitudinally the bunch is still increasing. In the absence of a dedicated buncher cavity the first accelerating cell must be used to impose some bunching while the beam is still malleable. To achieve this, the

electron bunch is simply injected at a negative phase. With larger gradient comes more acceleration, however, the energy spread and non-linearity in the bunch is also increased, and so longitudinal emittance grows. Recovering the longitudinal properties in the following components is complex. Compression of the electron bunch longitudinally at low electron energies results in space charge blow-up transversely. At non-relativistic energies the coupling between the longitudinal and transverse phase space is pronounced. The bunch properties are very sensitive to changes in the cavity gradient, phase and solenoid field strength.

Varying the solenoid strength changes the transverse dimensions of the bunch entering the cryo-module. Rather than focus the bunch to a minimum before entering the first cell, a modest setting is chosen so as not increase the bunch length further. Transverse compensation can be achieved partially by RF focusing in the cryo-module.

The 3rd harmonic cavity is used to impose some linearity on the longitudinal phase space. The electron bunch is injected into the 3rd harmonic cavity with a negative phase without decelerating the bunch ($-90 < \phi < 0$). The more negative the phase used, the shorter the bunch length and longitudinal emittance, but also the less acceleration. There is of course a trade-off with transverse emittance growth which increases. It is not possible to operate the 3rd harmonic cavity with a positive phase as this creates a transversely convergent bunch. This combined with the RF focusing in the following two accelerating cells results in transverse cross-over and non-laminar flow.

The final two cavities are used to accelerate the bunch to relativistic energies ($\beta \sim 0.9$) before exiting the cryo-module. The RF focusing in these two cavities, when the bunch is injected near the maximum accelerating phase, is strong. Hence the linearity of the resultant electron bunch is highly dependent on the relation between the 3rd harmonic and final accelerating cavity settings both longitudinally and transversely.

The evolution of the electron bunch through the injector for the first-pass modelling can be seen in Figure 3. The results shown have a final mean energy of just less than 5.5MeV. This is below the design energy of at least 7MeV. Manually trying to increase the exit energy whilst maintaining modest emittances and bunch lengths proved problematic. This is due to the complexity of the interactions between the components.

OPTIMISATION ALGORITHM

In an effort to further improve the design the multivariate optimisation program that was first used at Cornell University, was applied to this geometry. The details regarding the use of an evolutionary algorithm to explore the parameter space and find optimal solutions are covered in depth in [6].

The injector design had a total of 10 free parameters that could be varied; all gradients and phases except the gun, the solenoid peak field and the rms laser spot size. Those that were kept constant included the component

positioning and the bunch emission length. Preliminary tests showed that optimised solutions converged at the practical limit imposed on the gun voltage from the available power supply (500kV). Several constraints were applied to the optimisation to ensure sensible output and realistic solutions. In particular, the exit energy was constrained to be above 7MeV to meet the specification. Initial optimisation runs used a small number of macro particles to simulate the injector in ASTRA to reduce computation time. Once an optimised region had been found it was possible to then run a more detailed simulation to improve accuracy.

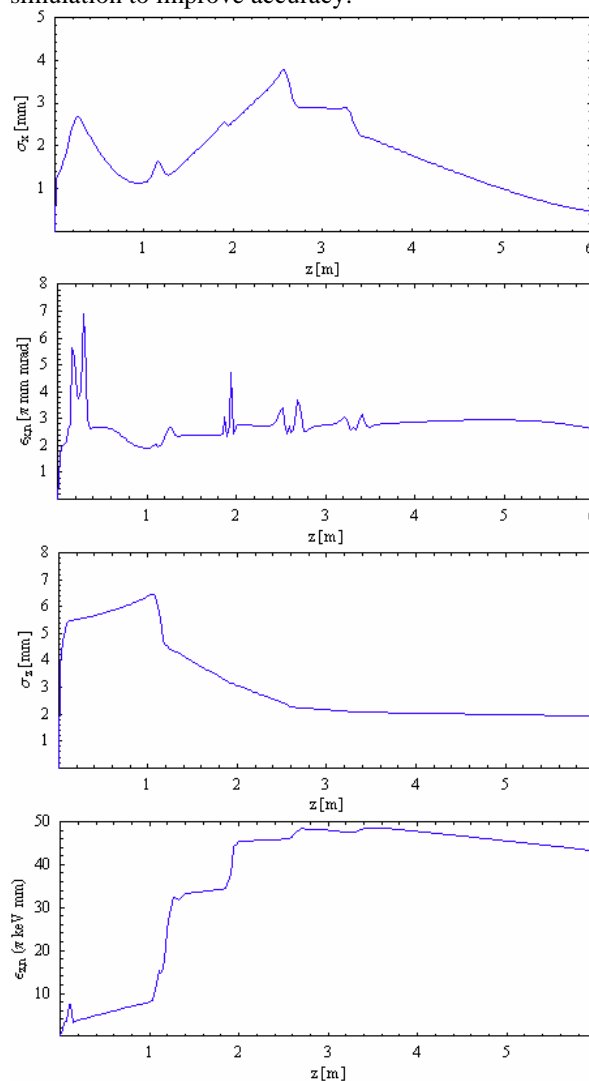

Figure 3: Bunch Evolution as a Function of Distance from the Cathode.

A two-objective optimisation was used to minimise transverse and longitudinal emittance simultaneously. The trade off between longitudinal and transverse performance at the end of the injector is shown in Figure 4.

The evolution of the electron bunch through the injector for a sample solution is shown in Figure 5. The parameters at the exit of the injector for the optimisation output compared to those manually achieve are shown in Table 1. The optimisation process has produced a solution

that has maintained similar parameters at the exit whilst increasing the energy of the bunch.

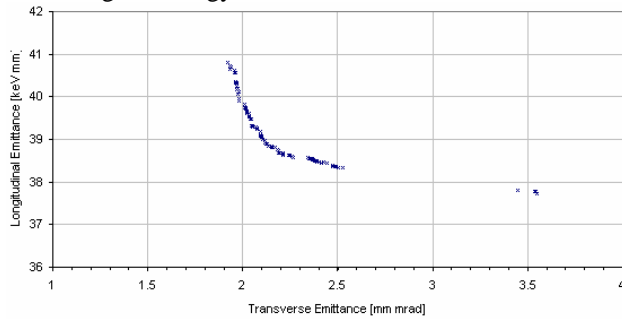

Figure 4: Longitudinal rms emittance versus transverse rms emittance.

Table 1: Comparison of the injector parameters for the manually found solution compared to that from the multivariate optimisation

	Manual Sol ^a	Multi-variate
Charge (pC)	135	135
Laser spot size, rms (mm)	1.25	2
Solenoid peak field (T)	0.042	0.038
SRF cavity 1 peak gradient (MV/m)	13	23
SRF cavity 1 phase (deg)	-40	-32
SRF 3rd harm. peak gradient (MV/m)	10	12
SRF 3rd harmonic phase (deg)	-10	-54
SRF cavity 3 peak gradient (MV/m)	17	22
SRF cavity 3 phase (deg)	-5	-7
SRF cavity 4 peak gradient (MV/m)	20	23
SRF cavity 4 phase (deg)	9	5
Transverse emittance, rms(mm-mrad)	2.7	2.3
Longitudinal emittance, rms(mm-keV)	43	37
Bunch length, rms (mm)	1.9	1.5
Mean energy (MeV)	5.4	7
Energy spread, rms (keV)	45	78

CONCLUSION

By using multivariate optimisation it has been possible to increase the exit energy of the injector to the design value. In addition, there are slight improvements in both longitudinal and transverse emittances. With increasing the mean bunch energy the energy spread has also risen as would be expected from this system. It may be possible, with further investigation, to reduce the energy spread and longitudinal properties at the expense of transverse emittance (as there is some margin in the specification here) if this is deemed to improve the FEL performance.

Construction of the DC gun and cryo-module is due for completion in 2006.

ACKNOWLEDGMENTS

This manuscript is authored by Jefferson Science Associates, LLC under U.S. DOE Contract No. DE-AC05-06OR23177. The U.S. Government retains a non-

exclusive, paid-up, irrevocable, world-wide license to publish or reproduce this manuscript for U.S. Government purposes.

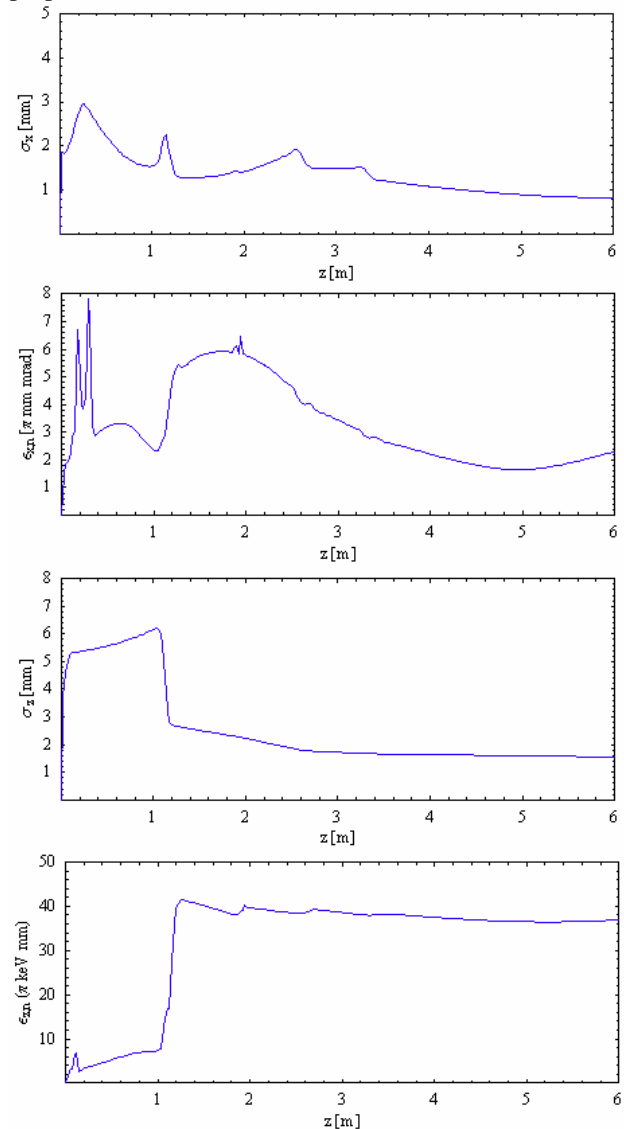

Figure 5: Bunch Evolution as a Function of Distance from the Cathode

REFERENCES

- [1] A. Todd et al: "High Power Electron Beam Injectors For 100kW Free-Electron Lasers", PAC 2003
- [2] A. Todd et al: "State of the Art Electron Guns and Injector designs", PAC 2005
- [3] J. Rathke et al: "Design and Fabrication of an FEL Injector Cryomodule", PAC 2005
- [4] K. Floettmann; ASTRA homepage http://www.desy.de/~mpyflo/Astra_dokumentation/
- [5] P. Hartmann et al: "A Diffusion Model for Picosecond Electron Bunches from Negative Electron Affinity GaAs Photocathodes", J. Appl. Phys., Vol 86, No. 4, 1999
- [6] I. Bazarov et al: "Multivariate Optimization of a High Brightness DC Gun Photo-injector", Phys Rev ST Accel Beams 8, 2005