

PROGRESS ON THE CTF3 TEST BEAM LINE

S. Döbert, G. Rumolo, D. Schulte, I. V. Syratchev, CERN, Geneva, Switzerland
 D. Carrillo, CIEMAT, Madrid, Spain

Abstract

In CLIC, the rf power to accelerate the main beam is produced by decelerating a drive beam. The Test Beam Line (TBL) of the CLIC Test Facility (CTF3) is designed to study and validate the drive beam stability during deceleration. This is one of the R&D items required from the International Linear Collider Technical Review Committee to demonstrate feasibility of CLIC. It will produce 30 GHz rf power in the GW range and allow to benchmark computer codes used for the CLIC decelerator design. Different options of this experimental beam line are discussed.

INTRODUCTION

The CLIC test facility will demonstrate the essential parts of the CLIC drive beam generation scheme consisting of a fully loaded linac, a delay loop and a combiner ring [1]. The final CTF3 drive beam delivered to the CLIC Experimental Area (CLEX) comprising the test beam line and a two beam test stand, has an energy of 150 MeV, 35 A of beam current, a bunch repetition frequency of 15 GHz and a pulse length of 140 ns. The emittance is assumed to be 150 μm and the bunch length 0.6 mm rms. Main differences between the CTF3 beam and the CLIC drive beam are the energy and the current. The CLIC drive beam has a beam current of 180 A and is decelerated from 2.3 GeV to 0.23 GeV giving up 90% of its energy.

The aim of TBL is to extract as much energy as possible out of the beam and to demonstrate the stability of the decelerated beam and the produced rf power. The main issues are the transport of a beam with a very high energy spread with no significant beam loss and suppression of the wake fields from the power extraction and transfer structures (PETS). Additional goals for TBL are the test of alignment procedures and the study of the mechanical layout of a CLIC drive beam module with some involvement of industry to build the PETS and rf components. Finally TBL will produce rf power in the GW range which could be used to test several accelerating structures in parallel.

POWER EXTRACTION STRUCTURE

The most demanding and restricting component in TBL is the PETS. The main emphasis in designing PETS for TBL was on extracting as much power as possible while balancing the wake field effects and providing enough geometrical aperture for the beam to pass. Furthermore the PETS tested in TBL should be as close as possible to the actual CLIC design. Recently, the base line design of the CLIC PETS [2] was evaluated in order to reduce the

peak power to be produced by the single structure by a factor two. The new 16 mm aperture ($a/\lambda=0.8$) PETS consists of eight identical racks with shallow corrugations separated by 1.5 mm slots for the damping of the transverse HOM, and equipped with a new very compact and efficient rf power extractor based on a single mode approach, see Figure 1.

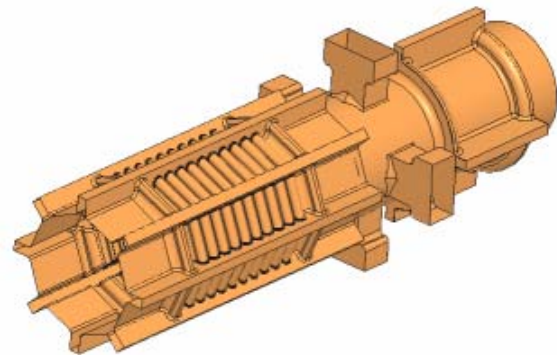

Figure 1: The general view of the 16 mm aperture PETS with 4-channel RF power extractor. The number of cells is not to scale.

In this design the 72 degrees phase advance per cell was chosen to reduce the impedances of very high order modes whilst keeping very strong damping for the dangerous modes and additionally to place the transverse wake zero crossings closer to the position of the bunches. The transverse wake impedances and amplitudes simulated with GDFIDL [3] are shown in Figures 2 and 3. The new PETS parameters are summarized in Tables 1 and 2.

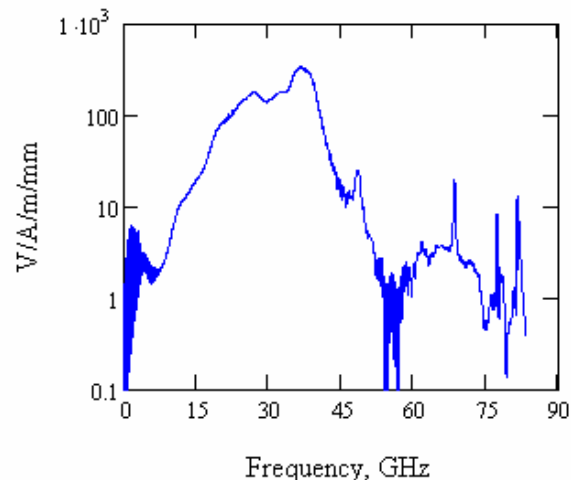

Figure 2: The transverse wake impedances for the new PETS design.

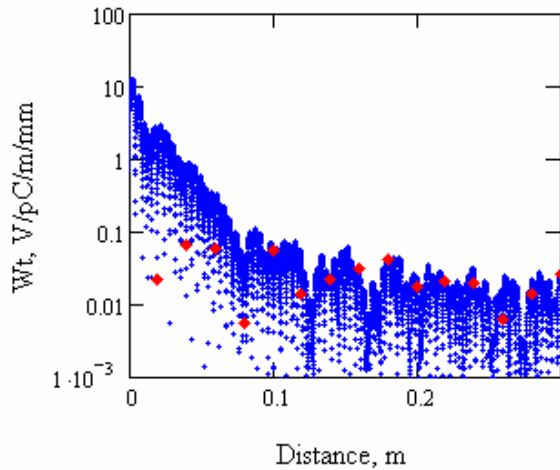

Figure 3: The new PETS transverse wake envelope. The diamonds corresponds to the wake amplitudes at the centre of the bunches.

Table 1: The CLIC PETS decelerating mode.

Frequency, GHz	29.9855
R/Q, Ω	1150
V group/ C	0.74
Q factor	6500

Table 2: The CLIC PETS transverse modes.

Mode number	Frequency, GHz	Wt V/pC/m/mm	Loaded Q factor
1	20	0.56	5.4
2	24.6	4.14	2.8
3	27.2	2.96	5.2
4	32.3	2.55	7
5	36.45	5.32	9.9
6	38.6	3.64	11

It turns out that the new PETS configuration is well suited to the TBL needs. The only difference is the length which is for TBL about twice as long as for CLIC to be able to extract enough power despite the lower beam current of CTF3. The PETS for TBL have therefore an active length of 0.8 m

The aperture appears to be optimized for TBL as well because a bigger aperture would reduce the wake fields but would lower the impedance and therefore the amount of deceleration obtainable for the given length of the beam line. Lengthening the PETS would help in this respect but would compromise the lattice stability as discussed in the next chapter.

TBL DESIGN

The test beam line will consist of a series of FODO lattice cells and a diagnostic section at the beginning and end of the line to determine all relevant beam parameters. Each cell is comprised of a quadrupole, a BPM and a power extraction structure. Each quadrupole will be equipped with remotely controlled movers for beam based

alignment. The quadrupoles and movers are developed by CIEMAT, Spain as a contribution to CTF3. The BPM's will most likely be a scaled version of the magnetic pick ups used in CTF3 and should reach a resolution of 5 μm [4]. The FODO lattice was chosen because of its energy acceptance. Due to transient effects during the filling time of the PETS the first 10 ns of the bunch train will have a huge energy spread from the initial energy down to the final energy of the decelerated beam. The lattice is optimized for the decelerated part of the beam, higher energy particles will see less focusing. The betatron phase advance per cell is close to the theoretical value of 90 degrees per cell for a round beam. A schematic of a TBL cell is shown in figure 4.

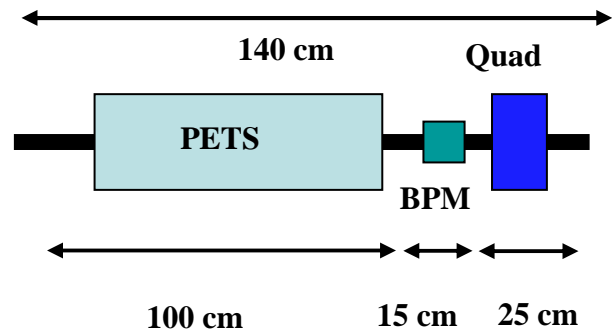

Figure 4: Schematic of a TBL cell.

The available space in CLEX allows the construction of up to 16 cells with a length of 1.4 m per cell. The nominal 35 A beam from CTF3 is decelerated by 5 MeV in each PETS, producing 160 MW of 30 GHz power. Already simple analytical calculation of the beam envelope assuming an ideal FODO lattice and taking into account the energy loss reveal that with the present CTF3 beam parameters the minimal transportable energy within the available aperture is 55 MeV. Figure 5 shows the beam energy and beam size as a function of the number of deceleration cells for the nominal beam parameters described above.

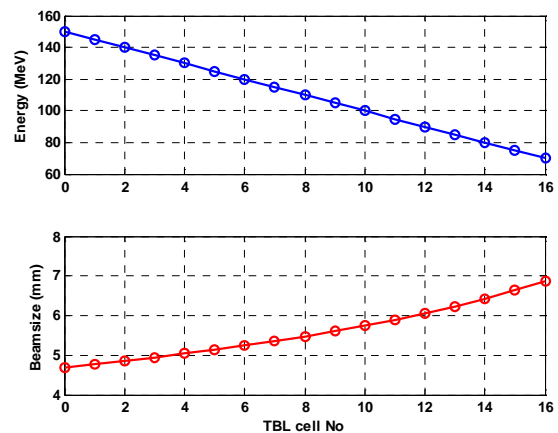

Figure 5: Energy profile and 3σ beam radius along the cells of TBL for the nominal beam parameters.

In this case 53 % of the available beam power would be extracted corresponding to 2.5 GW of 30 GHz rf power. The beam already fills most of the aperture although wake field effects and misalignment are not even taken into account. The properties of the higher order modes described in the previous chapter are used in a more sophisticated simulation with PLACET [5] to evaluate the effect of the wake fields. In TBL, the offset amplification factor due to wake fields is actually higher than expected in CLIC mainly due to the lower energy. The 3σ beam size along the line including the influence of various higher order modes is shown in figure 6.

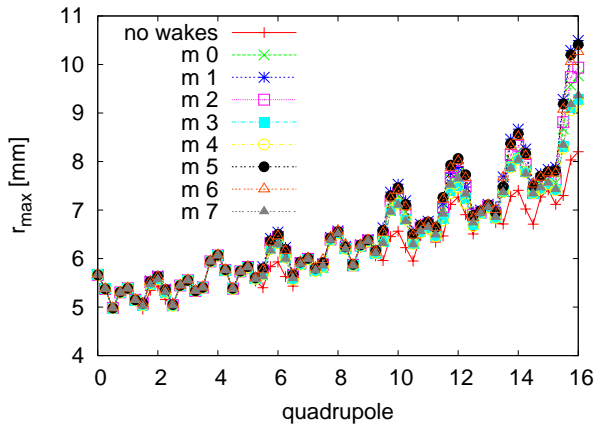

Figure 6: Maximum beam radius (3σ) along TBL. Simulations are done for a number of higher order modes and entirely without wake fields.

The wake field effects are responsible for about 20% of the beam size at the end of TBL. Therefore the minimum transportable energy in this line rises to 80 MeV which limits the extractable beam energy to 46% in TBL. For the nominal CTF3 beam parameters one would expect already some beam loss starting from cell 12 if the aperture in the quadrupoles is the same as in the PETS. Whether tapering out to a bigger aperture in the quads and BPM's is feasible has to be studied. The BPM aperture is specified to 22 mm to get the required resolution and the design of the quadrupoles would allow for 30 mm aperture.

The beta-function in a FODO lattice is proportional to the cell length. Shortening the cells would reduce the beam size accordingly but would reduce the active length for power extraction and therefore the extractable energy from the beam. A triplet lattice was excluded because of its lower energy acceptance. Significant improvement could come from a higher initial beam and a smaller emittance.

CONCLUSIONS

The design of the test beam line is mainly determined by the energy loss and the available geometrical aperture for the beam. Due to the lower energy in CTF3 compared to the CLIC drive beam a deceleration down to 10% of the initial energy is not possible. The maximum extractable energy for the nominal beam parameters is

about 46% which corresponds to more than 2 GW of 30 GHz rf power. The experiment will be very relevant for CLIC because the beam to be transported without losses has a much lower energy and the wake field effects are more severe. TBL will allow simulation codes and criteria used for the design of the CLIC decelerator as well as alignment procedures to be benchmarked. Furthermore it will be an engineering test facility for CLIC PETS and their infrastructure giving valuable input for further optimization of the CLIC module design. The rf power produced, being in the GW range, can be used at a later stage for simultaneous testing of rf components and accelerating structure with high power.

It is envisaged to build a FODO lattice with 16 cells, filling up entirely the available space, but to equip only 8 cells in a first stage with PETS. After gaining some experience with the beam line additional cells will be installed. According to the simulations discussed above the nominal beam can not be transported without losses to the end of TBL in a 16 mm aperture. It would be possible if, the input energy is higher, the emittance is smaller or the beam current is lower than anticipated. Due to the fully loaded operation of the CTF3 linac it is possible to trade off beam energy and current. However a lower beam current means lower extractable energy which is not desirable. It is foreseen to upgrade CTF3 with a photo injector which promises a much better emittance. This would allow decelerating the beam through the entire length of the test beam line without losses. The photo injector in principle would be able to produce two bunches with the right distance to be combined later on in the combiner ring to probe the wake fields from the PETS directly.

REFERENCES

- [1] G. Geschonke and A. Ghigo, "CTF3 Design Report", CERN/PS 2002-008 and LNF-02/008, 2002
- [2] H. Braun et al. "Updated CLIC parameters 2005", CERN-OPEN-2006-022; CLIC-Note-627.
- [3] The GdfidL Electromagnetic Field simulator, <http://www.gdfidl.de/>.
- [4] M. Gasior, "An Inductive Pick-Up for Beam Position and Current Measurement", CERN-AB-2003-053 BDI, Geneva 2003.
- [5] D. Schulte, "PLACET, A Program to Simulate Drive Beams", CERN/PS 2000-028 (AE), Geneva 2000.