

MECHANICAL AND THERMAL DESIGN OF VACUUM CHAMBERS FOR A 7 T MULTIPOLE WIGGLER FOR BESSY II *

D. Berger, H. Krauser, M. Rose, Hahn-Meitner-Institut, Glienicker Str. 100, 14109 Berlin, Germany
 V. Duerr, E. Weihreter, BESSY, Einsteinstraße 15, 12489 Berlin, Germany
 S. Reul, Fa. PRETECH, Tinsdaler Heideweg 2a, 22559 Hamburg, Germany

Abstract

A superconducting 7T wiggler with 17 poles will be installed in the BESSY II SR source. To handle the high radiation power of 56 kW emitted by the wiggler at 1.9 GeV / 500 mA, the vacuum chambers downstream of the wiggler, exposed to power densities up to 200 kW / cm², have to be designed with great care. In this paper the detailed mechanical design of a copper vacuum chamber is presented together with a numerical analysis of the temperature and stress distributions in the chamber walls. Special water cooled absorbers are required to keep the temperatures and stresses below critical limits.

1 INTRODUCTION

Dedicated hard X-ray beamlines are under construction by the Hahn-Meitner-Institute for residual stress analysis, magnetic scattering and small angle scattering experiments using the BESSY II SR source. To provide the required high flux in the energy range up to 60 keV at the medium energy (1.9 GeV) BESSY II storage ring, a superconducting 7 T wiggler with 17 poles and a period length of 148 mm is under construction [1]. For beam currents of 500 mA the wiggler emits SR with the total power of 56 kW in a fan with a horizontal aperture of almost +/- 24 mrad. Therefore, the vacuum chambers and absorbers downstream of the wiggler have to be designed with great care to withstand a very high heat load without excessive thermal deformation. In total, 45 kW of heat load is absorbed outside the beamlines.

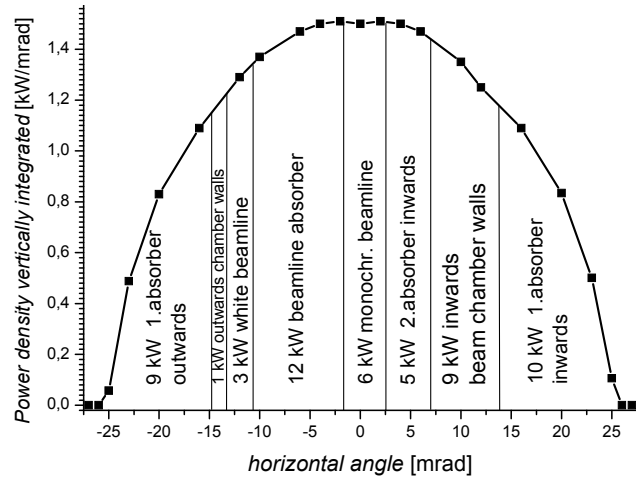

Figure 2: Horizontal power density distribution @1,9 GeV/ 500 mA

Figure 1 shows the layout of the vacuum chamber downstream of the wiggler where the thick line indicates the horizontal chamber aperture.

The aim of this paper is to present the main aspects of the vacuum chamber design including the calculations of the heat load on the vacuum chamber, the resulting temperature and stress distributions and the optimizations of the chamber profile and its cooling.

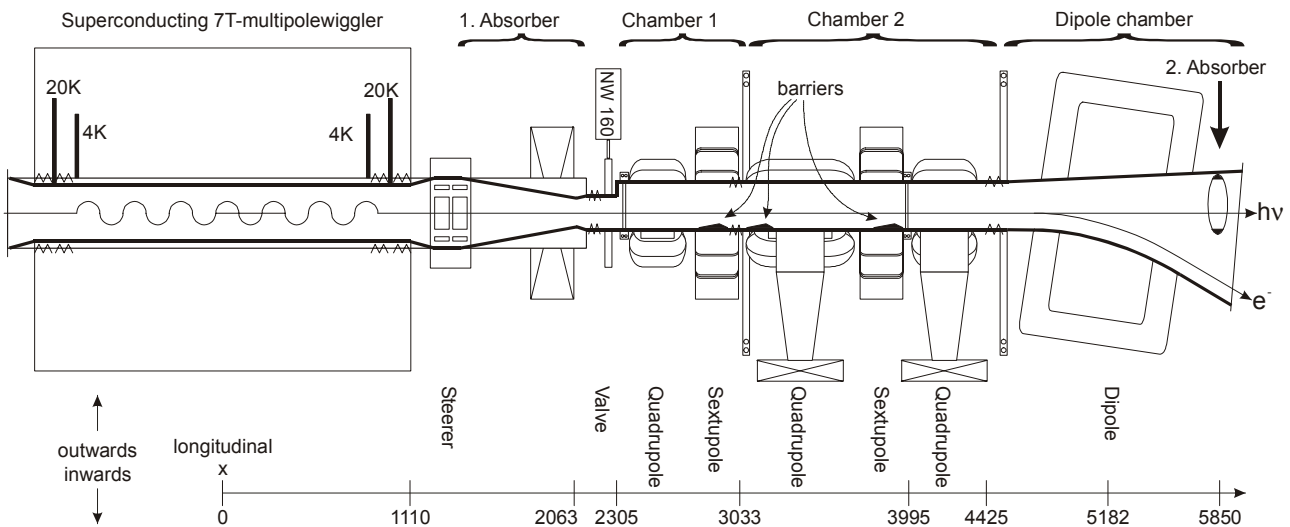

Figure 1: Vacuum chamber downstream of Multipole-Wiggler (transversal direction is 3x scaled up)

* work supported by BMBF / Germany (HGF Strategiefond)

2 CALCULATION OF HEAT LOAD AND TEMPERATURE DISTRIBUTIONS

The heat load on the vacuum chamber has been obtained from the energy selective spatial distribution of the synchrotron radiation of the wiggler calculated using the WAVE-code [2]. Starting from a calculation of the electron path in the wiggler field the code superimposes the radiation of all sources. Figure 2 shows the resulting horizontal power distribution integrated over the vertical opening angle together with the total heat load on several areas of the downstream vacuum chamber as indicated in figure 1. Beside the synchrotron radiation all other heat loads are negligible because all parts are cooled by a standard water cooling in any case.

Figure 3 shows the vertically integrated heat load on the inner vacuum chamber downstream of the wiggler plotted over the distance x to the wiggler center. The line density of the power decreases from about 7 kW / m at the entrance of chamber 1 to about 2 kW / m at the end of the dipole chamber. Using these heat loads the temperature distribution in both vacuum chambers is calculated using the p-element code Pro/Mechanica (TM) from PTC. Fig. 4 shows the temperature distribution along the inner walls of vacuum chambers 1 and 2 (s. Fig. 3) after all optimizations described in the following chapter 3.

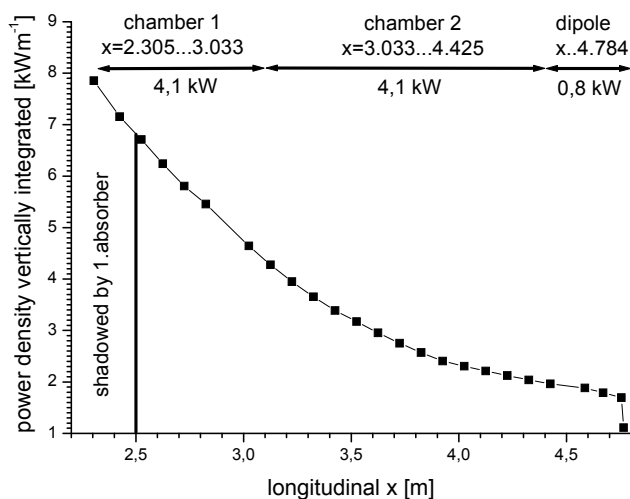

Figure 3: Heat load on inner vacuum chamber walls

3 MAIN CHALLENGES OF VACUUM CHAMBER DESIGN

Due to the small vertical opening angle of the SR (± 0.27 mrad), the heat load on the chamber walls is concentrated in a small ribbon of several 100 μm width giving a peak power density of up to 200 kW / cm^2 . Therefore, a high thermal conductivity is mandatory for the vacuum chamber material. Here all parts are made from the material CuAg0.1% which offers not only a high heat conductivity (393 W/mK) but also a high tensile strength (270 N/mm²) even for temperatures close to the Cu-melting point.

All parts that have to be made from other materials must be protected against radiation, e.g. the first absorber (see figure 1) protects the consecutive bellow and the valve. Moreover 3 barriers (figure 1) were implemented to protect the bellows and pumping ports of chamber 1 and 2.

The cooling pipes are directly milled into the chamber walls and are closed by a soldered cover. So the cooling pipes are as close to the heat sources as possible (the wall thickness is only 1.5 mm). The cooling pipes have an inner cross section of 8x4.5 mm² and a water flow rate of 3 m/s will be provided.

In addition to the thermal optimization of the chambers, the manufacturing process has to be optimized too, to minimize the risk of decreasing the material strength due to the machining or heat treatment during the soldering. Chambers 1 and 2 consist of two half shells produced from 5 mm sheet material. Both half shells are electron beam welded along a milled longitudinal seam. The dipole vacuum chamber also consists of two half shells which are directly milled from blocks of CuAg0.1%.

Special care was taken to reduce the number of soldering processes to one. The vacuum chamber is connected to the flanges via a manifold which itself consists of a copper part and a stainless steel part. Only the two parts of the manifolds are soldered, while the copper part of the manifold is welded to the Cu-chamber by e-beam. The stainless steel part of the manifold is welded to the flange with TIG, offering the advantage of possible correction of axial tolerances.

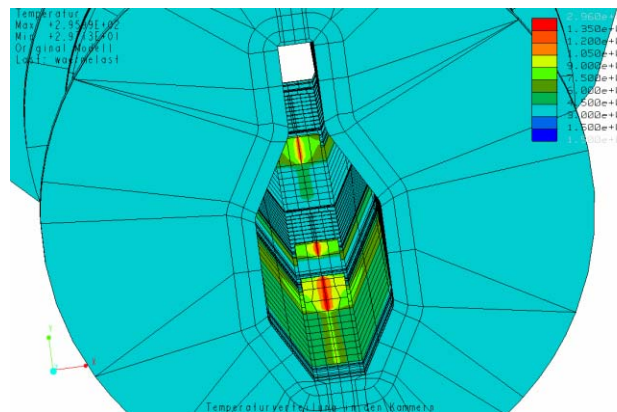

Figure 4: Temperature distribution inside of the vacuum chambers 1 and 2, the calculated maximum of 296 °C is a singularity, due to the high thermal conductivity mean surface temperatures are at around 150 °C (red)

With the calculated temperature distribution and the coefficient of thermal expansion, the stresses and displacements of the vacuum chamber can be determined. It is found that the stresses have the highest value of 120 N/mm² on the surface of the shielding barriers, all other parts are loaded with stresses below 50 N/mm² which is far below the static yield strength (yield point $\sigma_{0.2} = 280$ N/mm² for the used material). A good safety margin is essential to take into account the variable heat loads

during normal operation of the wiggler and the storage ring leading to frequent stress variations over many years. The displacement of the complete vacuum chamber is calculated to be smaller than 0.35 mm (s. Fig. 5). This is within the allowed tolerances.

4 ABSORBERS

Inside of the wiggler cryostat the vacuum chamber has a horizontal width of 110 mm to ensure that the cold part is not irradiated by SR. Standard horizontal aperture of BESSY vacuum chamber is 65 mm and the transition between both is done by the first absorber (see figure 1). Although the heat load is about 9 kW on the outer side and 10 kW on the inner side of this absorber, it is made from standard OFHC-copper. Because of the rather large absorbers length of 652 mm, the density of the heat load is small and the surface temperature is below 220 °C.

The second absorber (see figure 1) defines the outer aperture of the two beamlines and it is located after the dipole magnet downstream of the wiggler. Due to limited space the absorber has to be mounted through a CF 150 flange. Therefore, the device has a length of only 100 mm but an extremely high heat load of 5 kW on the inner side. Moreover it has to be taken into account that the radiation fan might have a vertical position variation of +/- 0.75 mm.

These strict requirements can only be met by a very compact design consisting of two wedge-shaped (angle 2°) absorber surfaces, a high cooling efficiency with four water pipes with diameter of 8 mm and four pipes with 6 mm and the use of the high-tensile strength copper-compound GlidCop 15. The temperature distribution in this absorber is shown in figure 6. Surface temperatures are calculated to be below 139 °C and tensile strength is below 160 N/mm² resulting in deformations below 0.4 mm, which are tolerable.

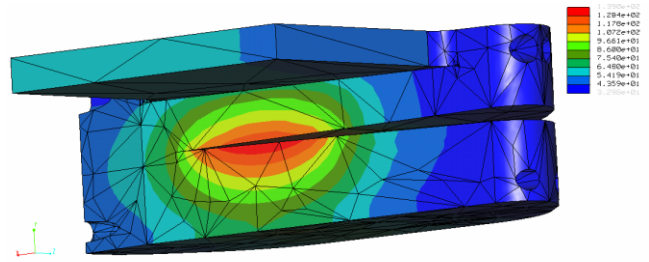

Figure 6: 2nd absorber: Temperature distribution on inward side, that defines the inner vertical aperture of the photon beam; 6 kW radiation impinges from right side, upper plate is used for mounting purposes

5 CONCLUSION

Parts of the vacuum chambers of the BESSY II ring are charged by powerfull heat load from a new 7 T wiggler with 17 poles. The heat load, temperature, displacement and stress distributions in the irradiated chambers and absorbers are numerically calculated as a basis for their optimization. The heat load removal reaches the technical limit and requires the use of special materials (CuAg0.1 and GlidCop), chamber designs (protection of sensitive parts) and the optimization of the manufacturing process.

6 REFERENCES

- [1] D. Berger, M. Fedurin, N. Mezentssev, S. Mhaskar, F. Schaefer, M. Scheer, V. Skharuba, E. Weihreter, „A superconducting 7T multipole wiggler for the BESSY II Ring“, PAC’01, Chicago, 2001
- [2] WAVE, program for the calculation of radiation characteristics of insertion devices and their effects on the particle dynamics written by M. Scheer / BESSY

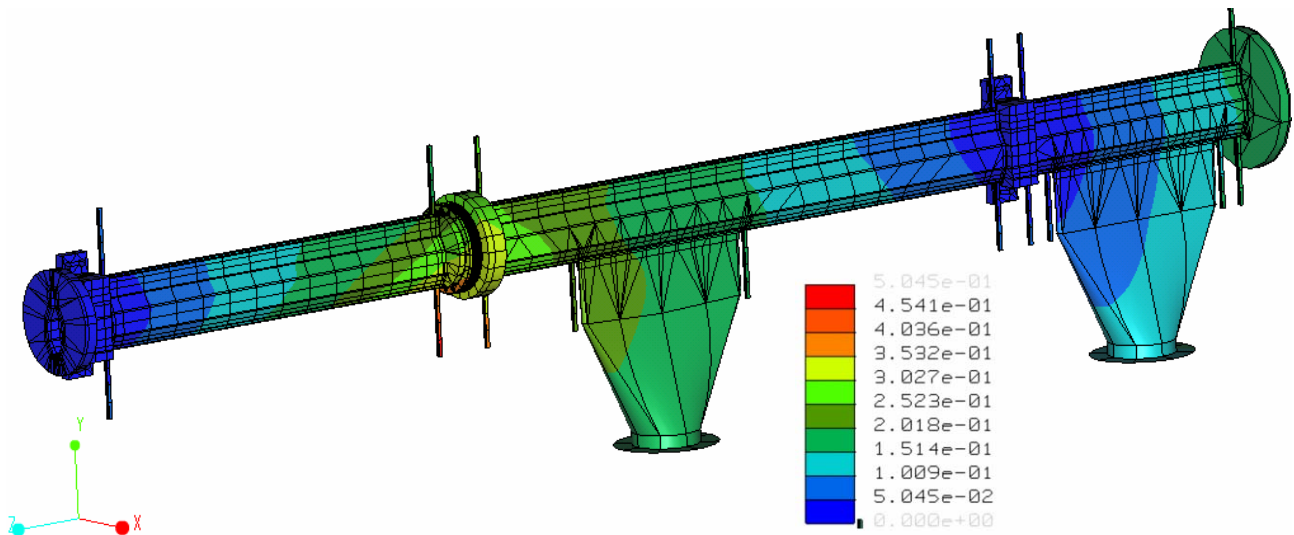

Figure 5: Displacements in all directions of vacuum chambers 1 and 2 due to the temperature loads; maximum displacement of the chamber walls is 0.35 mm