

ACCELERATOR CONTROL SYSTEM BASED ON RADIATION-ACOUSTIC EFFECTS

A.Styervoyedov, M.Silkin, A.Yatskov, Kharkiv National University,
4 Svobody sq., Kharkiv 61077, Ukraine

V.Farenik, Scientific Centre of Physical Technologies, Kharkiv, Ukraine

Abstract

Experimental equipment for radiation-acoustic emission investigations that includes radiation-acoustic sensors, analog-digital processor of acoustic signals and computer based software-hardware complex for multichannel amplitude-frequency analysis have been created and presented in this paper. Suggested scheme of the informational-measuring and controlling system of the accelerator that uses its radiation-acoustic image is described.

1 INTRODUCTION

Excitation of acoustic oscillations by pulse flows of energy is one of the most general macroscopical demonstrations of interaction of radiation with a substance [1,2]. Therefore, an interest of experts in the field of automation of electrophysical installations to this phenomenon is natural and it is stimulated by perspectives of new high informative measuring systems creation [3,4]. It is revealed, that intensity and spectrum of oscillations depends on modes of operation of the high-frequency system of the accelerator, conditions of a resonant exchange of energy between an electromagnetic field and a beam of accelerated particles [5,6], and also on a beam pulse current, cross dimensions of a beam and particles distribution on its cross-section [7]. Linear functional dependencies of time-space and amplitude-frequency characteristics of acoustic fields from the part of absorbed in the waveguide section SHF-power of pulses and also from the beam pulse current, beam current density and particles distribution on its cross-section are used for creation of new information-measuring and controlling units of the accelerator based on the radiation-acoustic effect.

2 EXPERIMENTAL PLANT

Simplified structural scheme of experimental plant is shown on fig. 3 An investigated sample – target (T), made coupled with an acoustic line and with an arranged piezoceramics converter on it (AS) that based on the piezoceramics PZT-19, is irradiated by the pulse beam of accelerated electrons. Registered signals are amplified by the amplifier (A) and passed through multiplexer (MUX) to the registering part of the scheme. At the same time signals are passed to the oscilloscope for observing. Dimensions of the electron irradiated region are restricted by the collimator (C). Pulse beams current is measured by

a magneto-inductive sensor (MIS) and voltage integrator (VI). MIS is calibrated by means of Faraday Cup (FC). Registration part of the scheme represents analog-digital processor of acoustic emission signals and consists of the peak detector (PD), analog-to-digital converter (ADC), comparator of overcoming by a signal of the preset reference level (AC), controlling microprocessor (MC), scheme of conditioning levels (LC) and IBM-computer with general and special software. Microprocessor's and computer's software coupled with the electronics part allows to organize a software-hardware amplitude analyser of acoustic emission signals.

As an example, amplitude dependencies of signals measured on the beam of accelerated particles are shown on fig. 1 and 2.

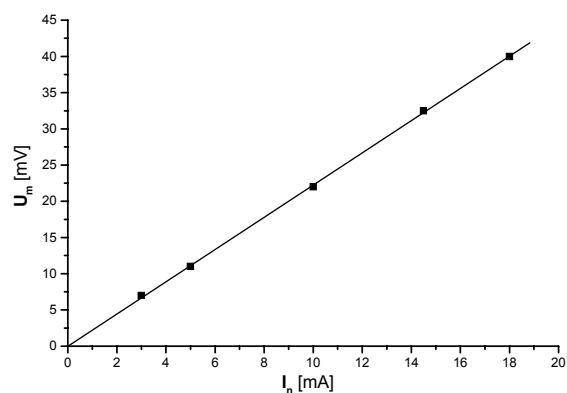

Figure 1: Dependency of the radiation-acoustic signal amplitude U_m from the beam current I_p .

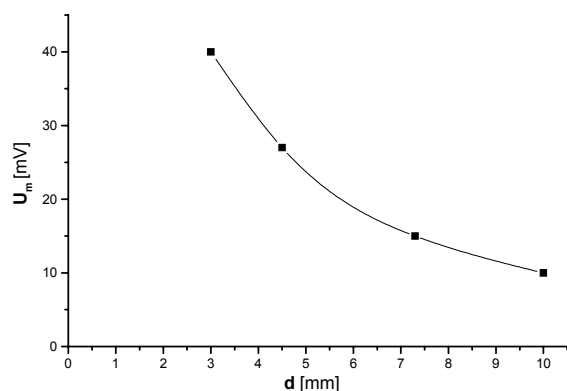

Figure 2: Dependency of the radiation-acoustic signal amplitude U_m from the beam's diameter d .

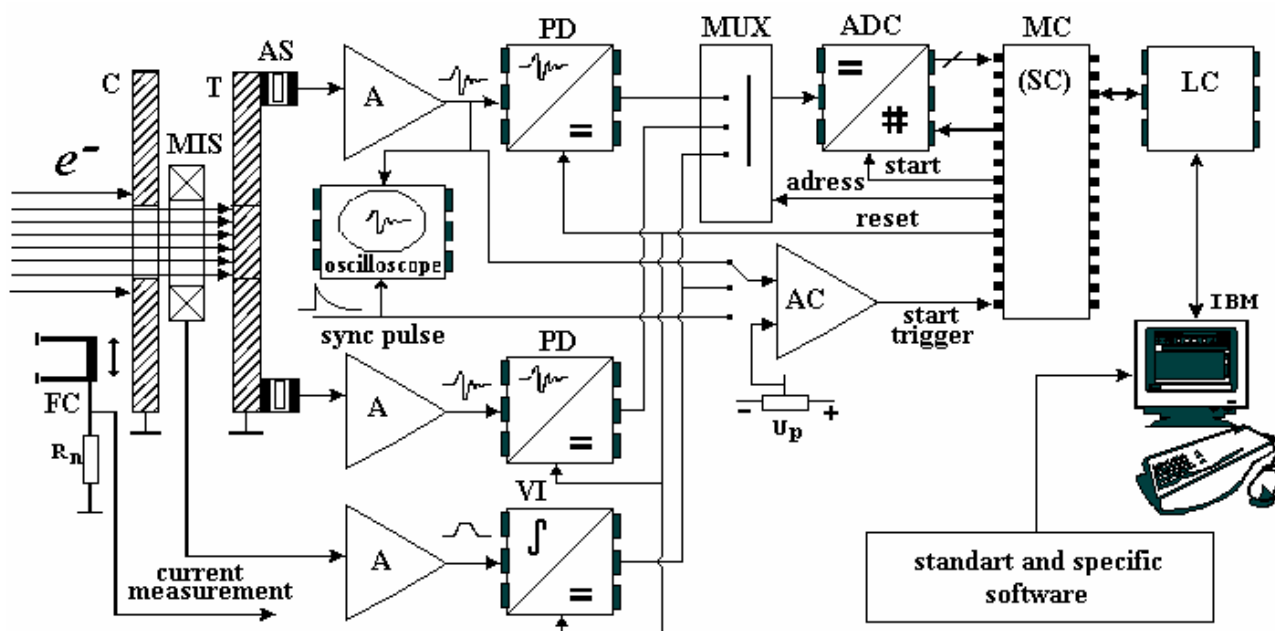

Figure 3: Scheme of experimental plant

3 RADIOACOUSTIC EMISSION IN DIAGNOSTIC SYSTEMS

Block diagram of the electron accelerator control system is shown in Fig.4. It consists of the acoustical sensors with electronic preamplifiers, CAMAC crate and IBM computer. Create is used for ultrahigh frequency field synchronization in an accelerating waveguide (AW) with electron impulses of linac injector, beam focusing on the target and measurements of electron beam parameters. The data analysis and control command generations are executed by the computer.

The primary information sources of the operation system are ultrasonic waves generated by the beam (σ_T) and high-frequency electromagnetic field (σ_p). When a pulsed electron beam hits linac constructive elements we have the rapid heating and expanding of their materials. Thus the generated acoustical emission gives information about beam parameters and location of the interaction points.

The acoustical waves are also generated by the pulsed high-frequency field interaction with waveguide elements. We can obtain the information about shape of the electromagnetic wave pulse, which depends on the energy exchange conditions between the high-frequency fields and electron bunches.

To detect acoustical waves σ_T , σ_p , the broadband piezoelectric sensors (AD1-AD7) are set on accelerator elements and target (T). These sensors have high sensibility and radiation resistance.

The high-frequency field synchronization is performed due to signals from the acoustical sensor (AD1) placed on an absorbing load. The energy transfer limit between high-frequency field and the electron bunches is attained when amplitudes of the acoustic stress is minimal. The

acoustical impulses from sensor (AD1) are transmitted to amplitude-digital converter of the crate. The corresponding procedure through the crate controller and a relay control units of the klystron (KL) phase-shifter (PS) servomotor make the minimum of the σ_p amplitudes, thus one results in the maximal energy transfer.

The automatic control of beam transport is performed due to signals from acoustical sensors (AD2) placed on the electron transfer line. Signals from the sensors are transmitted to both analog-to-digit and time-to-digit converters (TDC) in the crate. If the amplitude σ_T exceeds its threshold value we have the beam deviation from the transfer line axis. In this case determination of the beam position is performed due to delays of two acoustical impulses with respect to the sync pulse of the accelerator. Therefore corrective changes of the beam position magnets (BPM) have been implemented. The source of the deflecting currents has encoded remote control and is operated through corresponding unit in crate. The beam focusing and the beam parameter measurements are implemented due to signals from sensors placed on the target (AD4) and on the acoustic probe (AD3). The signals are digitized by gated analog-to-digit converter in the crate and analyzed by corresponding subprogram. The system controls the current from the focusing lens (FL) by the digit-to-amplitude converter to retain a specified spot diameter. Because of the pulse delay from (AD4) with respect to the sync pulse, the current position of the spot was determined. It allows performing the subsequent control of current shape of the magnetic scan deflector (BCD) and keeping proper dose distribution on the target, when scanning beam is used. By this means duration and frequency of electron bunches, beam energy, electron spot dimension and location on the target have been determined.

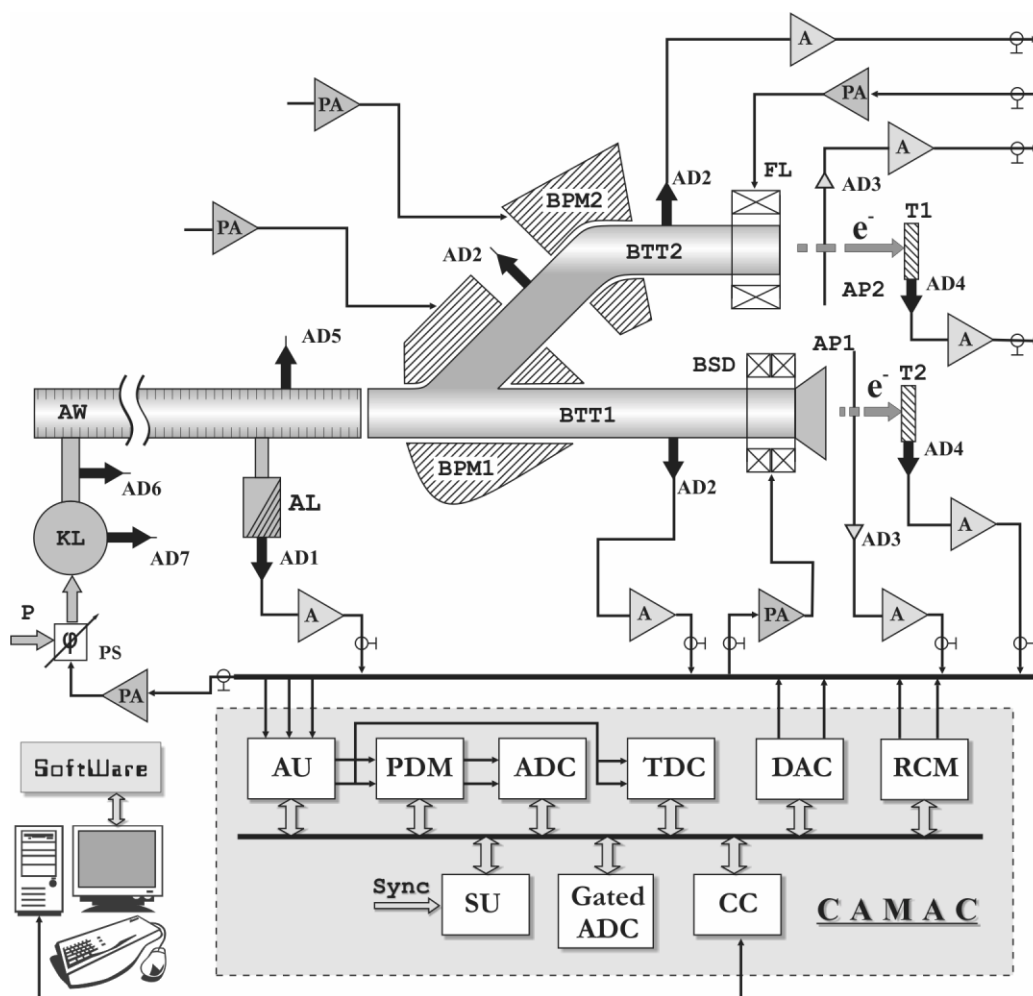

Figure 4: Block diagram of the electron accelerator control system based on radiation acoustic defects.

In this diagnostic system, there is the supervisor program, which keeps the reports of the experiment and displays current information on the monitor screen. This program enables to test the system, to display signals from the sensors, to change parameters of the beam with respect to operator instructions, and to calculate a dose profile in the target. Such system can also be used to synchronize ultra high-frequency fields of the separate parts of a multisectional accelerator and to protect a high-current linac from proper beam damages.

4 REFERENCES

[1] Yu.V. Kapurin, V.T. Moisyev, V.V. Petrenko. Atomnaya Energiya, 63, № 6, p. 400-402 (1987)
 [2] R.M. White, J.Appl. Phys., 34, №12, 3559(1963)

[3] B.B. Oswald, Jr., D.R. Schallhorn, H.A. Eisen, F.B. McLear, Appl. Phys. Lett., 13, №8, 279 (1968)
 [4] I.I. Zalyubovskii, A.L. Kalinichenko, V.T. Lazurik, Introduction to Radiation Acoustic [in Russian], The Higher School, Kharkov (1986)
 [5] N.G. Styervoyedov, The Automatic Focusing Manner of The Pulsed Charge Particle Beam, Patent SU №1695397, (1991)
 [6] G.F. Popov, V.G. Rudnev, N.G. Styervoyedov, Scanning Beam Radiation Monitor of The Ionizing Particles, Patent SU № 1760869, (1992)
 [7] V.A. Deryuga, G.F. Popov, A.L. Kalinichenko, A.G. Ponomarev, V.V. Uvarov, Excitation of Acoustic Oscillations by Destructive Electron Impact on Polycrystalline Metal Targets