

PROBLEMS OF INSTALLATION OF VIBRATING WIRE SCANNERS INTO ACCELERATOR VACUUM CHAMBER*

S. Arutunian[†], A. Avetisyan, N. Dobrovolski, M. Mailian, I. Vasiniuk, YerPhI, Yerevan, K. Wittenburg, DESY, Hamburg, R. Reetz, HTM Reetz GmbH, Berlin

Abstract

In [1] the frequency of self-oscillations is proposed to use as information about the interaction rate of charged particles on the wire of a beam-profile wire scanner. The frequency strongly depends on the wire temperature. The temperature is determined by the beam intensity in the wire cross section. Oscillations are excited by an interaction of an alternating current in wire with a permanent magnetic field. In this work the problems of the installation of a vibrating wire based scanner into a vacuum chamber of an accelerator are discussed: Restriction on the scanner magnet system due to beam dynamics, problem of installation into vacuum chamber, scanning mechanism development, influence of temperature, material choice, thermo-compensation assembling and electrical disturbances from the beam. Based on the notices [2] it is proposed to investigate also the possibility of oscillation excitation by mechanical stimulation. Another possibility of excitation can be a parametric resonant mechanism generated by special piezoelectric transducers. Oscillations can be detected by piezoelectric or optical ways and can also serve as source of beam profile information.

1 INTRODUCTION

The wire scanners are widely used in accelerators. In such devices the wire is used as a target and source of secondary particles and radiation. Different materials for wires were investigated: Carbon (C), Quartz (SiO_2), Ceramic (Al_2O_3) [3].

During the scanning the wire is heated significantly (see e.g., [4]). In [5] detailed information about process on wire heating is described. The most part of the total energy deposited in the wire is transformed into heat, e.g. at 100 MeV kinetic energy proton beam 35.5 keV is deposited in wire as heat and only 0.67 keV is leaving the wire through the nuclear interaction. In [1] it is suggested to use the information about heating of the wire as a main signal to exclude the complicated unit for monitoring of secondary radiation/particles arising at the beam scattering. Vibrating wire fastened on the both ends has an increased sensitivity with respect to the temperature of the wire [6, 7]. The temperature sensitivity of the vibrating wire sensor estimated on the level 10^{-4} °C.

At present some preparations for installation of the vibrating wire scanner (VWS) into the circular electron accelerator of YerPhI and PETRA, DESY are done. The

corresponding incuts into the vacuum chamber and the system of vibrating wire feed are made. The sensor itself already is tested on laser beams and gas jets. Both mentioned tasks are interesting themselves. Profiling a laser beam without distorting it may be of interest for tracing of alignment laser beams in accelerators.

2 MAGNET SYSTEM AND WIRE OSCILLATION SYSTEM

In VWS the generation of wire's vibrations is achieved by means of interaction of the alternating current passing through the wire with the permanent magnetic field. Strong samarium-cobalt magnets are used, which provide a field strength of order and higher than 8 kGs in the working range.

The magnetic fields of VWS can be concentrated only on definite parts of the wire, in a such way, that the remaining magnetic field free part of the wire can be used for scanning.

Taking into consideration the scheme of correction of magnetic disturbances of dipole and quadrupole terms, we propose a system of magnetic field which possesses a maximal degree of symmetry. The central part is left free for beam scanning, and the parts near the nodes are located in antisymmetric regions of magnetic field (see fig. 1).

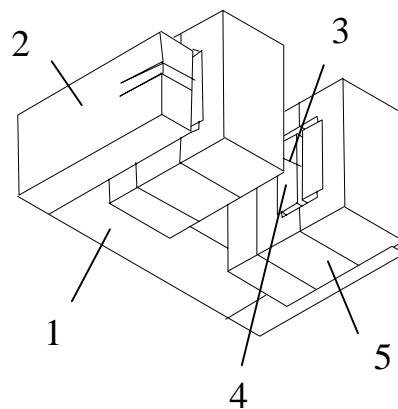

Figure 1: The main view of the vibrating wire sensor. By numbers are indicated: 1 - the sensor base, 2 - one of the clips, 3 - vibrating wire, 4 - magnet, 5 - magnet core.

It is foreseen, that usage of corresponding magnet cores will allow to diminish the sensor's magnetic field's influence on the beam to an acceptable level.

*The work is done in the frame of ISTC A-347 Project
[†]femto@uniphi.yerphi.am

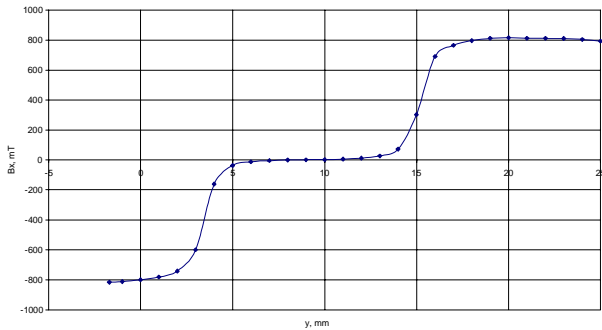

Figure 2: Magnetic field in the gap of the VWS. Wire is oriented along the vertical y-axis and the magnetic field is directed along the horizontal x-axis.

As it is seen from the fig. 2, the field in the gaps of the sensor magnet system of the sensor decreases considerably near the beam region.

Another scheme of 2-wire construction of the sensor may be also used. Namely, the wire is divided in two parts. First, situated in the magnetic field, is ended on the rocker (this is the vibrating part of the wire). Next part is a continuation of the first part and is also pressed on the rocker and is ended on the clip. This part of the wire is not vibrating. It can be made of nonconducting material and serve as a thermosensitive part of the scanner. Difficulties of the realisation are connected with the installation of the rocker on hinges (prevents displacement of the vibrating wire's end in the transversal direction to the wire, leaving the longitudinal displacements free), and also with a refusal of the another method of scanning (see fig 3).

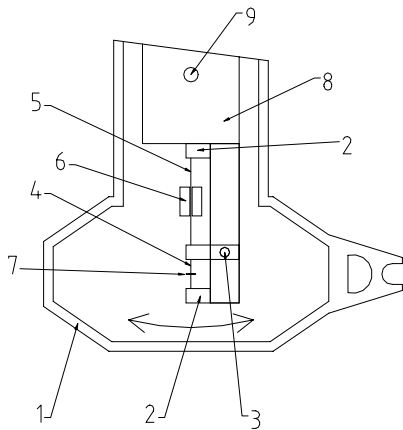

Figure 3: Two-wires construction of the sensor. By numbers are indicated: 1 - vacuum chamber of accelerator, 2 - wires clips, 3 - hinge rocker, 4 - sensitive to temperature scanning wire, 5 - vibrating wire, 6 - sensor magnetic system, 7 - beam of the charged particles, 8 - the base of the sensor with axis of rotating 9.

As seen from above the disturbances from sensor magnetic field can be reduced down to required level. However, partially placement of the wire in the magnetic system gap also disturbs the thermal distribution along the

wire. The wire will also feel the temperature of environment via transfer of heat through the magnetic system elements. Such a heat transfer is very inertial and therefore the correction by an additional thermometry of the magnet system requires a complicated data processing. From this viewpoint it is preferred to minimize number of neighboring to the wire parts, in particular, the magnetic system. To register the wire oscillations, piezoelectric transducers can be used. Preliminary experiments show that a thin bar of piezoceramics with thickness 0.3 mm gives a suitable for registration signal. In notice [2] was considered mechanical oscillations of the wire excited at wire movement. It seems, that by special mechanical forcing it is possible to excite required oscillations of the wire. Excluding of magnetic field allows to use dielectric wires, which is important at intensive beams scanning.

3 VWS INSTALLATION

For the wire's transfer, it is suggested to use high vacuum linear translators.

The scanner's details are made of metals (stainless steel, bronze, tungsten) and dielectrics - quartz or optical glass.

On the fig. 4 is presented a section of circular electron accelerator of YerPhi with incut flange for mounting of scanner mechanism with vibrating wire sensor. The beam will be measured in the linear section, where the beam injected into the accelerator ring. This location is chosen for measurement of profile of a beam of energy 50 MeV. A silphon mechanism with fine feed (1 μm per step of a computer controlled step motor) is used as a scanner. The electronic part of the wire oscillations generation is placed at short distance from the scanner (in the accelerator tunnel). Then the frequency signal is transmitted to the computer of control panel by a cable of length about 75 m. Motion of the scanner is done in range of 27.7 mm, with maximum speed 0.2 mm/s.

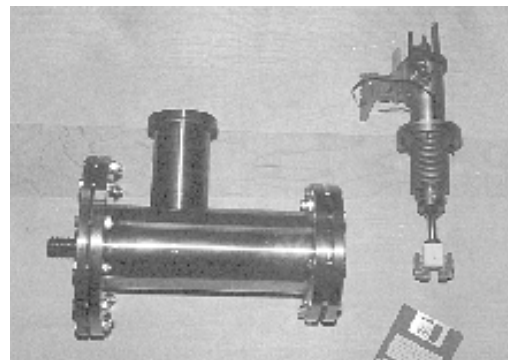

Figure 4: The part of vacuum chamber with incut flange for vibrating wire scanner. The vibrating wire scanner maintained on the bar of the silphon of translator mechanism.

4 INFLUENCE OF TEMPERATURE

The VWS is very sensitive to the temperature of the base to which the vibrating wire is fastened. In modifications of the sensor, elaborated for thermogravimetry this problem was solved by thermostabilisation of the base. However, the mentioned scheme requires additional devices placed into vacuum chamber (heating cartridge, thermometer, as a rule a thermoresistor). It is possible to correct the obtained data using temperature, however, its measurement by ordinary methods also can arise difficult problems. The most correct way is seen to be the choice of the material for the base with a minimal coefficient of thermal expansion. Such materials can be special alloys. Quartz with coefficient of thermal expansion on the level of few 10^{-7} K^{-1} is also very suitable.

5 ELECTRICAL DISTURBANCES

The beam scattering on the wire will induce some leakage currents through the conducting wire. Such currents seems will be small and have DC character and can be removed easily from the autogeneration scheme. In [1] the wire heating modeling was produced by such DC currents of order of few hundreds mA, much more than the autogeneration currents. Leakage current can provide additional information on the process scattering and can be used for sensor calibration.

Besides the beam scattering processes the wire will be also heated due to the beam electromagnetic fields (synchrotron radiation in the bent parts of trajectory, wake fields). The synchrotron radiation can be separated out taking into account its horizontal asymmetry. The more complicated is the separation of wake fields.

6 EXPERIMENTAL RESULTS FOR AIR JETS

As it mentioned above the experiments with the vibrating wire profile meter were done for laser beams [6, 7]. A resolution of order of $5 \cdot 10^{-4} \text{ W/cm}^2$ of radiation power density was achieved. The power measurement threshold was 10^{-5} W and the energy (for pulsed lasers) was 10^{-5} J at linear dynamic interval of the sensor radiation intensity greater than 10^3 [7].

In some areas of techniques, e.g. in problems of hardening of glass in furnaces by air-cooling it is required to justify the profile of the air. Clearly this task is to be solved by a nondestructing method. In fig. 5 we present results of monitoring of air jets by vibrating wire sensor, satisfying the condition of nondestructivity.

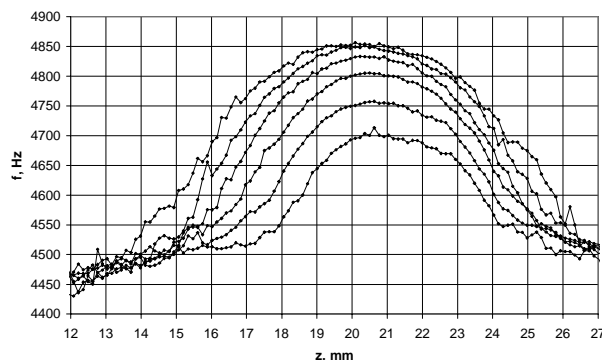

Figure 5: The different sections profile of air jet measured by vibrating wire scanner.

Profiles of air jet with total flow about 3.53 l/min. In this case the vibrating wire was fed by a direct current and its cooling at different locations in the jet were measured. On the figure profiles in different orthogonal cross-sections at distance 4 mm from each other (corresponding graphics are located from down to up in increasing order of distance from the nozzle). It is seen that response of frequency change is increased with increment of distance from the nozzle. It seems strange but it can be explained by the fact, that at a close distances from the nozzle only a small part of the wire is cooled. With increasing of distance from the nozzle the heating part is increased and correspondingly increased, and it must be taken into account by calibration.

7 REFERENCES

- [1] Arutunian S.G., Dobrovolski N.M., Mailian M.R., Sinenko I.G., Vasiniuk I.E. Vibrating wire for beam profile scanning.- Phys. Rev. Special Topics-Accelerators and Beams, 1999, v. 2, 122801.
- [2] Wittenburg K. Notizen zu den Schwingungsmessungen am Faden des Kohlefaden-Profilmonitors.- desyntwww.desy.de/mdi/...schwing.html, 1990.
- [3] S.Striganow, G.Schmidt, K.Wittenburg, Estimation of the signal from the wire scanner in the TTF.
- [4] K. Wittenburg, Emittance (profile) measurements in the proton accelerators at DESY.
- [5] P.Elmfors, A.Fasso et al., Wire scanners in low energy accelerators.- Nucl. Instrum. Methods, Phys. Res., A: 396(1-2) (1997) 13-22 (20 p.) 1997.
- [6] Arutunian S.G., Dobrovolski N.M., Mailian M.R., Oganessian V.A., Vasiniuk I.E. Nonselective receiver of laser radiation on the basis of vibrating wire.- Proc. Conference Laser 2000 (November 2000, Ashtarak, Armenia).
- [7] Arutunian S.G., Dobrovolski N.M., Mailian M.R., Oganessian V.A., Vasiniuk I.E. Vibrating wires fence as a negligibly destructive beam profile and beam position monitor.- Proc. Conference AWA (July 2001, Nor Amberd, Armenia), p.303.