

HIGH CURRENT TANDEM ACCELERATOR FOR INTENSE MONOCHROMATIC GAMMA RAYS GENERATION

L. Barkov, G. Derevyankin, G. Dimov, G. Kraynov, A. Krivenko, S. Fadeev, V. Shirokov, G. Silvestrov, I. Sorokin, S. Taskaev, M. Tiunov, BINP, Novosibirsk, Russia
V. Mashinin, MPhI, Moscow, Russia

Abstract

Original 2 MeV proton tandem accelerator with current 10 mA for monochromatic 9.17 MeV gamma-quantum production on Carbon-13 target for contraband detection is described. The tandem is supplied by a powerful sectioned rectifier from ELV type industrial accelerator providing high stability of the proton beam in the region of maximum gamma rays production at protons energy 1.75 MeV. Variants of gas stripper system and design of 100 kW Carbon-13 target with liquid metal cooling are presented. Also the results of optics calculation for focussing on stripper of 10 mA compensated H^- beam with heterogeneous density and transverse energy about 1 eV are given.

1 INTRODUCTION

One can find explosives or drugs in luggage and cargo with modern physical methods. The Nuclear Resonance Absorption (NRA) method [1,2,3] uses resonant absorption of monochromatic 9.17 MeV gamma radiation in nitrogen. The majority of explosives and drugs contain plenty of it.

We offer the original proton tandem accelerator with current 10 mA for a detection system on basis of the NRA method. The 1.75 MeV proton beam impinges upon Carbon-13 target. Photons are obtained by $^{13}C(p,\gamma)^{14}N$ reaction. Emitted at 80.7° angle to the proton beam photons are resonant for absorption in ^{14}N . The width of the resonant gamma ray is 0.7° .

A suitable reaction zone of a ^{13}C target is thin, before protons are scattered. The proton energy must be resonant with high stability. In work [3] it is supposed for proton energy stability to be better than 1%. We expect it in order of 0.1 %.

A proton current on the target more than 5 mA is desirable [3]. For high beam current the tandem accelerator with vacuum insulation provides the higher reliability compared to tandem based on accelerating columns with ceramic insulation.

2 RESULTS AND DISCUSSION

Fig. 1 shows the construction of vacuum insulation tandem accelerator developed at BINP. The tandem is supplied by a sectionalized rectifier from industrial ELV-type accelerator 1, with an output voltage up to 1.5 MV and a power up to 100 kW. The output voltage stabilization in the source of a stage-type with an accelerator inductive link and parallel power supply of stages was considered. The developed system enables one

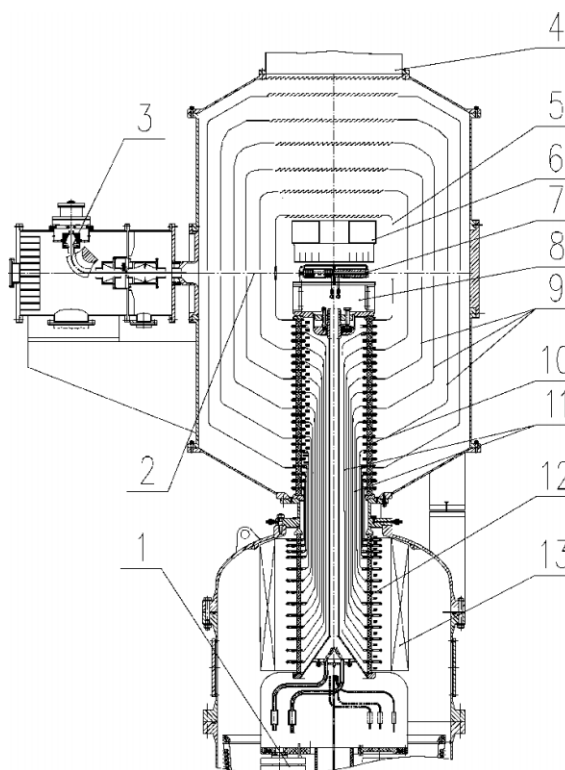

Figure 1: Vacuum insulation tandem

to keep the accelerating voltage within accuracy higher than 10^{-3} . A system of active suppression of ripples allows to keep ripples of rectified voltage at the same level.

Negative hydrogen ion beam 3 is injected into electrostatic tandem accelerator with vacuum insulation. After charge-exchange of negative hydrogen ion in proton inside charge-exchange tube 7 in the center of high-voltage electrode 5, a proton beam at the outlet of the tandem is accelerated to double voltage of high-voltage electrode.

The new concept of surface-plasma source with current up to 40 mA is offered [4].

The charge-exchange tube has an inner hole of 6-15 mm diameter and ~ 400 mm length. The next gas charge-exchange targets were assigned to be used:

- Argon gas target with only outer pumping through the heads of potential shields and mouth 4.
- Argon gas target with recycling turbo-molecular pumping inside the high-voltage electrode.
- Gas target with gas freezing on the nitrogen trap inside the high-voltage electrode. Pump 6 can be filled with liquid nitrogen. In this case some gases, as CO_2 , NH_3 are supposed to be used as charge-exchange gas.

Different potential shields 9 provide the homogeneous distribution of the potential and preventing the full voltage effect.

The most important component of the accelerator is the high-voltage through-pass insulator, which transfers the high-voltage powerful source potential into the vacuum tank from the tank filled with SF₆ gas. Insulator can be arbitrarily remote from the accelerated beam passage region 2. Thin wall pipes of various lengths 11 connect the respective metal rings of different potential on the gas part 12 of the insulator and its vacuum part 10. Through-pass insulator is filled with SF₆ gas under the pressure lower, than outside gas part insulator pressure. The resistive divider 13 provides the homogeneous distribution of the potential along the insulator length.

The electrostatic intensity at accelerating gaps is 33 kV/cm. The energy storage in every high-voltage vacuum gap is lower than 20 J. It is determined that overvoltages on the high-voltage vacuum gaps and insulators are permissible at ELV breakdowns at full voltage or breakdowns of any vacuum gap. Therefore, there is no need to mount a compensating capacity divider.

Fig. 2 shows the numerical simulation results of beam transport in electric and magnetic fields taking account of

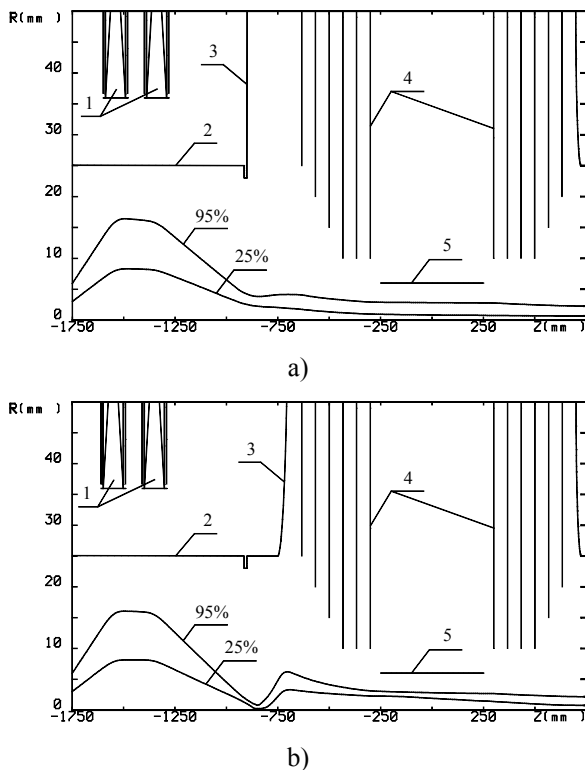

Figure 2: Computer simulated envelopes for "soft" (a) and "hard" (b) introduction of 10 mA beam into tandem accelerator. 1 – magnetic lenses, 2 – drift tube, 3 – vacuum tank, 4 – high-voltage electrode, 5 – charge-exchange tube

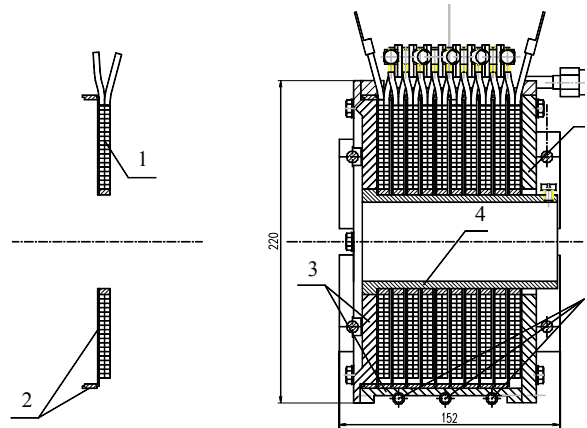

Figure 3: Magnetic lens. 1- busbar wire, 2- aluminum disk, 3- magnetic shield, 4- lens framework, 5- tubes of cooling system.

space charge and emittance of the beam. A "soft" beam introduction (fig.2, a) into tandem is realized by more fluent increase of electric field for Pierce geometry of electrodes. Accelerating voltage must be in good accordance with ion beam density in that case. The simulation was made by ExtraSAM [5]. One of the magnetic lenses fig.2, 1 is shown on fig. 3

A diamond-like ¹³C film or porous titanium oxide saturated by ¹³C are supposed to be deposited on the beam absorber, fig. 4. This plate has a system of cooling channels, and liquid gallium will be pumped through them. Two designs of the target are described [6]:

- Stationary target like disk 50 mm in diameter with power removal capability of several tens of kW.
- Rotating target with power removal more than 100 kW. It includes pump for pumping of liquid metal coolant and heat exchanger with secondary cooling contour.



Figure 4: Beam absorber, view from proton beam side.

3 CONCLUSION

A set of experiments on study of high voltage durability of vacuum gap with large square electrodes were finished on available pulse tandem-accelerator.

The 2.5 MeV tandem accelerator is under construction now in a 3-layered protected bunker with necessary infrastructure. Mechanic and mounting works at sectionized rectifier were finished at its working place, it was started-up and operating voltage of 1.25 MV was obtained. Design drawings for high voltage through-pass insulator and draft for accelerator were prepared. Vacuum tank for accelerator was manufactured. Design of high voltage electrodes of rectifier and tandem was finished.

Simulation of transport of a dense beam is carried out taking account of space charge and emittance of the beam. An analysis of different types of charge-exchange target had been made. Thermal mode of the beam absorber was investigated using electron beam up to tens of kW and both water and liquid metal cooling systems.

4 REFERENCES

- [1] D. Vartsky and M.B. Goldberg, An Explosives Detection System For Passenger Baggage Based on Nuclear Resonance Absorption in ^{14}N , Proposal to FAA (1986).
- [2] D. Vartsky *et al*, A method for detection of explosives based on nuclear resonance absorption of gamma rays in ^{14}N , NIM, A, 348(1994), 688
- [3] B. Milton. A High Current Tandem Accelerator for Gamma-Resonance Contraband Detection, PAC, 1997, Vancouver, B.C., Canada
- [4] G.I.Dimov "Tandem surface-plasma source", RSI, v.73, 2, February 2002, p. 970
- [5] M.A. Tiunov, G.I. Kuznetsov, M.A. Batazova. Simulation of High Current Electron and Ion Beam Dynamics for EBIS. The 8th International Symposium on Electron Beam Ion Sources and Traps EBIS/T 2000, BNL (USA), November 6-8, 2000.
- [6] G. Silvestrov, High Power Neutron Producing Target with Liquid Metal Cooling, this proceedings.
- [7] G. Derevyankin, G. Kraynov, A. Kryuchkov, G. Silvestrov, S. Taskaev, M. Tiunov. The ion-optical channel of 2.5 MeV 10 mA tandem accelerator. Preprint BINP 2002-24. Novosibirsk, 2002.
- [8] M. E. Veis, S. N. Fadeev, N. K. Kuksanov, P. I. Nemytov, V. V. Prudnikov, R. A. Salimov and S. Yu. Taskaev. Stabilization of accelerating voltage in HV-tandem accelerator for neutron capture therapy. Preprint BINP 2002-17. Novosibirsk. 2002.
- [9] <http://www.inp.nsk.su/medicine/bnct/index.en.shtml>