

AN INTENSE GAMMA-RAY SOURCE WITH COMPTON BACKSCATTERING

Yoshikazu MIYAHARA
 SPring-8, Mikazuki, Sayo-gun, Hyogo 679-5198, Japan

Abstract

Feasibility study of an intense gamma-ray source with Compton backscattering has been carried out. High infrared radiation power, generated with a superconducting linac FEL, is collided between optical mirrors with an intense electron beam in a storage ring to generate several times of 10^{12} quanta /s at an energy of 1~20 MeV for nuclear experiment. An energy resolution of about 1 % with a pinhole or a circular slit is possible by using a 1 GeV electron beam with a small emittance and small energy spread.

1 INTRODUCTION

High energy gamma-rays are useful tools for experimental studies of nuclear and hadron physics. In the past, gamma-rays have been generated by bremsstrahlung of high energy electron beam, capture reactions such as (p, γ) or (n, γ) , positron annihilations, and Compton backscattering. Gamma-ray intensities by these methods, however, were rather weak. Owing to recent advance of high power lasers, high current electron storage rings, and precise solid state detectors of electrons, Compton backscattering has become very attractive methods. Remarkable performances of this method have been recently demonstrated in the LEP33 beamline in the SPring-8 storage ring in a GeV energy range [1].

As an experimental tool, gamma-rays are required to be intense, monochromatized and polarized. All these requirements are satisfied to considerable extent by Compton backscattering. In addition, gamma-ray energy range can be selected by experimental requirements.

The laser power so far used is 10~20 W and the intensity of gamma-rays is in an order of $10^{6\sim7}$

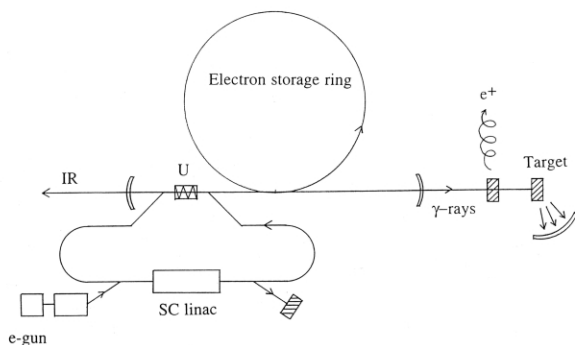

Fig.1 Schematic layout of the accelerator complex for Compton backscattering.

Table 1 Relations among FEL wavelength, storage ring beam energy and gamma-ray energy generated by Compton backscattering

Wavelength (mm)	0.25	0.5	1	2	5	$\epsilon_{\gamma\max}$ (MeV)
	400	500	710	1000	1690	10
SR energy (MeV)	560	710	1000	1420	2250	20
	680	870	1230	1740	2750	30

quanta/s. To increase the intensity, there has been proposed to use an output power of about 1 kW generated by a superconducting linac infra-red FEL [2]. Meanwhile, intense gamma-rays in an order of 10^7 quanta/s have been observed by FELs in electron storage rings [3], where gamma-rays are generated by the collision of generated FEL power in the cavity with the driving electron beam.

Recently, an intense infra-red power of about 1 kW was successfully generated by superconducting linac FELs [4,5]. It is supposed that intra-cavity power could be 100 kW or more in the FELs. In the present paper we consider to perform Compton backscattering (CBS) using an intra-cavity FEL power to generate gamma-rays at a rate of 10^{12} quanta/s or more and an energy resolution of about 1 %.

In such a high intensity, the tagging method cannot be applied to determine the gamma-ray energy. Instead, a pinhole or a circular slit is used for energy monochromatization. For a high energy resolution of gamma-rays we need a small emittance and small energy spread of electron beam. In addition, by using a planar or helical undulator for the FEL, linearly or circularly polarized FEL power is generated, with which polarized gamma-rays can be generated.

Since the intra-cavity FEL power is desired as high as possible, high reflectivity mirrors for the FEL are essentially important. Recently, multi-layer dielectric mirrors with a reflectivity of 99.999 % or higher have been developed around a wavelength of $1 \mu\text{m}$ [6]. Although the wavelength of the FEL should be selected considering the application of FEL output power, we tentatively assume a wavelength of $1 \mu\text{m}$, a mirror reflectivity of 99.995 %, and a mirror absorption ratio of 0.005 %.

Table 1 shows the relations among FEL wavelength, storage ring beam energy and the maximum

Table 2 Parameters of main superconducting linac.

Beam energy	E_L	63	MeV
Normalized emittance	ϵ_n	7	mm-mrad
Energy spread	σ_E/E_L	± 0.2	%
Peak current	I_p	50	A
Average current	I_0	12	mA
RF frequency	f_{rf}	508.6	MHz
Repetition frequency	f_p	46.2	MHz

Table 3 Parameters of FEL.

Wavelength	λ_s	1	μm
Laser beam radius	σ_r	1.5	mm
Initial gain	G_0	6	%
Output average power	$\langle P_0 \rangle$	4.6	kW
Intra-cavity peak power	P_s	2000	MW
Intra-cavity average power	$\langle P_s \rangle$	460	kW

gamma-ray energy generated by CBS. The storage ring beam energy is assumed to be $E_R=1$ GeV to generate gamma-rays in an energy range of 1–20 MeV. A ring with an energy of 1–1.5 GeV is moderate in size and not heavy in its construction, operation and maintenance. Figure 1 shows the schematic layout of the accelerator complex for CBS.

2 SUPERCONDUCTING LINAC FEL

Table 2 represents the parameters of a main superconducting linac for FEL. An electron beam, generated by a thermoionic gun with the aid of a grid pulser about 1 ns length is bunched to a length of 5 ps by conventional and superconducting cavities, and accelerated to 63 MeV by the main linac, which comprises 4 or 5 units of 5 cell superconducting cavities acting at 508 MHz. After the FEL, the beam power about 720 kW is converted to the linac energy via recirculation, and the beam is dumped with a beam power about 70 kW.

The parameters of a planar undulator for the FEL are a periodic length of $\lambda_0=20$ mm, number of periods $N_u=40$, and K-value $K=1.0$. A helical undulator has similar parameters. The radius of laser beam power is $\sigma_r=1.5$ mm at the undulator, and the initial gain is $G_0=6$ %. The gain decreases near the power saturation, and eventually becomes equal to power loss. According to a numerical simulation, intra-cavity peak power is $P_s=2$ GW for a power extraction loss $T=1$ %, when the phase advance of electron beam per pass through the undulator is about 2π . The average intra-cavity power is $\langle P_s \rangle=460$ kW, and average output power is $\langle P_0 \rangle=4.6$ kW. Power absorption in a mirror is 23 W.

There is a similarity of the envelop between the laser beam in an optical cavity and the electron beam in a

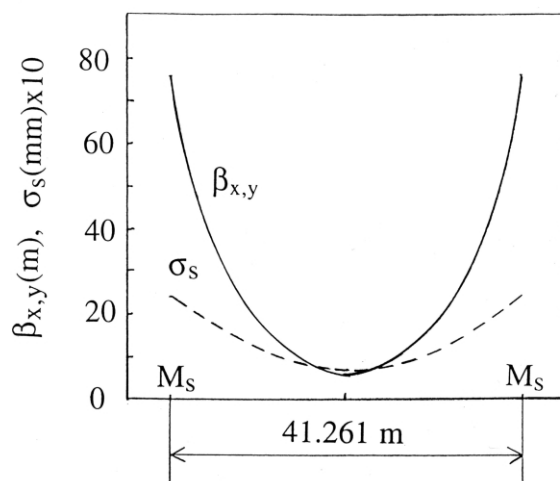

Fig.2 Beta function and laser beam size in an optical resonator.

storage ring, both of which take Gaussian form in the transverse direction. The emittance of the laser beam is given by $\epsilon_s=\lambda_s/4\pi$, which is also related to the uncertainty principle, $\Delta x \Delta p_x = h/2\pi$, with h the Planck's constant. Circular mirrors with a curvature of R_s can be regarded as thin lens with a focal length of $f_s=R_s/2$, and the one set of mirrors is regarded as a unit cell for the repeatedly reflecting laser beam. Thus the laser beam envelop can be calculated similarly as the electron beam by the matrix method for the Twiss parameters.

Mirrors with $R_s=20.030$ m are placed with 41.261 m apart and the calculated beta function and laser beam size are shown in Fig.2. Stability condition $|\cos \Delta\psi| < 1$ for the photon beam is satisfied since the phase advance of betatron oscillation of photons is $\Delta\psi=-0.845$. It is noted that the undulator is placed not in the place of laser beam size minimum but in the place rather close to one of the mirrors. In such a situation, the electron beam size for the FEL should be approximately matched to the laser beam size. If the electron beam size is too small compared with the laser beam size, the newly generated laser power per pass through the undulator will diverge significantly because of the uncertainty principle.

3 COMPTON BACKSCATTERING

The structure of the electron storage ring and the optical resonator for the FEL are shown in Fig.3. Parameters of the storage ring are given in Table 4. The emittance and energy spread of the electron beam are reduced to 13 nmrad and 4.7×10^{-4} , respectively, to generate a higher energy resolution.

The interaction region length for CBS is $L_{int}=5.9$ m, where the laser beam size is $\sigma_r=0.69$ mm and the electron beam size is $\sigma_{x/y}=0.35 / 0.22$ mm with full coupling, which is effective to reduce the horizontal divergence of the electron beam and thereby the

Table 4 Parameters of electron storage ring for Compton backscattering.

Beam energy	E_R	1.0	GeV
Beam current	I_0	500	mA
Circumference	C	94.31	m
Natural emittance	ϵ_x	13	nm-rad
Energy spread	σ_E/E_R	4.7×10^{-4}	
RF frequency	f_{rf}	508.6	MHz
RF voltage	V_{rf}	0.8	MV
RF bucket height	ΔE_m	23	MeV

divergence of the gamma-rays. Total generation rate of gamma-rays is given by

$$dN_\gamma/dt \approx 2L_{int}(dN_s/dt)(dN_e/dt)\sigma_\gamma/c\Sigma_s$$

where dN_s/dt and dN_e/dt are the rate of laser photons and circulating electrons passing the interaction region, and σ_γ and Σ_s are the cross section for CBS and laser beam, respectively. We expect $dN_\gamma/dt \approx 1.2 \times 10^{13}$ quanta/s and total power of gamma-rays is $P_\gamma \approx 18$ W. If the laser beam size is reduced by a factor of 2, the generation rate is increased by a factor of about 4, which however, needs a more precise control of electron beam orbit in the storage ring.

The gamma-ray energy by CBS is given by

$$\epsilon_\gamma \approx 4h\nu_s\gamma^2/[1+4h\nu_s\gamma^2/E_R + (\gamma\theta)^2]$$

where θ is the scattering angle of gamma-rays, and $h\nu_s$ is the laser photon energy. The maximum gamma-ray energy is 19 MeV. Above expression is similar to that of the synchrotron radiation from an undulator, and the gamma-ray generation by CBS can be regarded as a synchrotron radiation from an undulator made of laser field. The electric and magnetic field of the laser beam affect the Lorentz force on the electrons in the same direction, and the effective magnetic field of the laser beam is 3.1 T at the peak laser power, but the K-value is very small as $K=1.4 \times 10^{-4}$ because of the very short wavelength. Linearly or circularly polarized laser beam can be regarded as a linear or helical undulator, with which linearly or circularly polarized gamma-rays are generated.

The gamma-rays are monochromatized by using a collimator or a circular slit. Energy resolution of gamma-rays is determined by the energy spread and divergence of electron beam, and by the angle width of collimator or slit. Independent resolution by the energy spread, divergence and angle width with $\Delta\theta=5 \mu\text{rad}$ are 0.09 %, 0.34 % and 0.96 %, respectively. These resolutions contribute to the total resolution by square, so that the total resolution is 1 %.

The electrons are scattered transversely by CBS. But

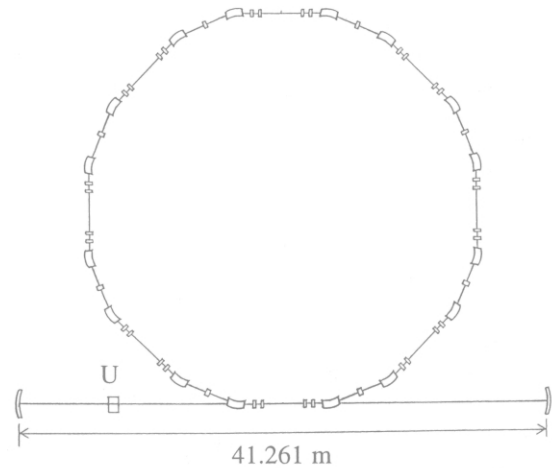

Fig.3 Structure of an electron storage ring and the optical resonator for FEL.

the scattering angle is very small, so that the increase of the transverse beam size of electron beam is negligibly small. Longitudinally, the energy loss of electrons to the gamma-rays induces an increase of the synchrotron oscillation amplitude of the electron beam. The energy spread increases from $\sigma_E/E_R=4.7 \times 10^{-4}$ to 2.3×10^{-3} or to $\sigma_E=2.3$ MeV, which is still 10 times smaller than the RF bucket height of 23 MeV. The maximum energy loss of electron beam is lower than the bucket height. Therefore no reduction of electron beam lifetime is expected.

4 CONCLUSION

Combining a superconducting IR-FEL and a small emittance electron storage ring directly, an intense gamma-rays about 10^{13} quanta/s with a resolution of about 1 % in an energy of 1~20 MeV can be expected by Compton backscattering. Although the parameters for the present system are demanding, the requirements seem in the range of current accelerator technologies.

REFERENCES

- [1] J. K. Ahn et. al., Proc. 12th Accel. Sci. Tech. Wako, Japan 1999, p141
- [2] E. L. Saldin et. al., Nucl. Instrum. Methods, A **362** (1995) 574.
- [3] M. Hosaka et. al. ,Nucl. Instrum. Methods, A **393** (1997) 525.
- [4] E. J. Minehara et. al., Nucl. Instrum. Methods, A **429** (1999) 9.
- [5] S. Benson et. al., Nucl. Instrum. Methods, A **429** (1999) 27.
- [6] G. Rempe, R. J. Thompson and H. J. Kimble, Optics Lett. **17** (1992) 363.