

SLOW EXTRACTION CONTROL USING THE DIGITAL FEEDBACK SYSTEM

H. Nakagawa, H. Sato, J. Kishiro, K. Marutsuka, M. Shirakata, KEK, Tsukuba, Japan
H. Tanaka, K. Mochiki, S. Arai, Musashi Institute of Technology, Tokyo, Japan

Abstract

Development and beam observation and various feedback tests of the hardware have been carried out for the purpose of both of utilization experiment of DSP and characteristic improvement of slow extraction. In recent experiment using DSP, it was possible that ripples were made to decrease in comparison with the analog feedback to 30% at the proportion of the ripple of the spill. Both of the method for using for the decrease in ripple content rate and observation result are described.

1 INTRODUCTION

For the physics research application, various methods are proposed and have been tested for extract the beam from the accelerator. Though it is a typical method to utilize a half integer resonance, it recently and often utilize the method using 1/3 resonance for the reason that the extraction efficiency is good. By using in a half integer resonance from a past, beam extraction is carried out at the KEK PS. Under this constraint, whether that the proportion of the ripple of the spill decreases even how, when DSP is used, is possible is tested[1]. Of course, the technology of this digital feedback using DSP is useful, even if the extraction method is changed in the 1/3 resonance technique. In addition, the digital feedback is more useful than the analog feedback in both sides of research and operation, since the reproducibility in the operation is excellent. Besides, it is easy to manipulate the feedback property as a function in the time, and "the ideal extraction operation" can be easily realized. By using DSP, it is reported to succeed in the control of the ripple which is included for the spill.

2 EXTRACTION SYSTEM

There are two groups from the viewpoint of doing the power supply control of the equipment for extraction.

- 1) The beam -> monitor -> feedback circuit -> power supply -> beam.
- 2) The pattern generation circuit -> power supply -> beam.

It has been produced by the arbitrary function generator, and the current of bump electromagnet and 8 pole electromagnet, septum electromagnet is the control

of the open type. 3 quadrupoles electromagnets have been installed at 2 groups in order to control the tune for half integer resonance extraction. They have been named EQ, RQ1, RQ2, and the feedback based on the spill signal is carried out in order to generate these current patterns. For this extraction control, the analog feedback circuit keeps be used in the historical reason.

3 BEAM OBSERVATION

It is the equipment in which being indispensable by the experiment which improves characteristics of the spill, observes the beam. And, it is also necessary that it measures the control condition and watches the equipment which they may be a noise source. By combining module of the WE7000 series made by YOKOGAWA ELECTRIC, it was moved as a digitizer of the 8 channels simultaneous sampling, and it was used for the measurement. Measuring objects are current, beam spill, current pattern value of EQ, RQ, beam intensity of the electromagnet of the lattice. Then, the frequency component was decided by the analysis of the data. One of the characteristics of the beam got by the process for the control experiment is shown in figure 1. In this figure, it is shown that extracted beam quantity changes with the time for fixed change of current of EQ. When both of momentum distribution and spatial distribution of the beam are considered, this phenomenon is the reasonable fact. Then, this indicates that the gain of the feedback must be made to change with the time in order to do the optimum control. And, it is known that there is a frequency which causes the oscillation near 1kHz on this extraction system[2]. The analytical result of frequency

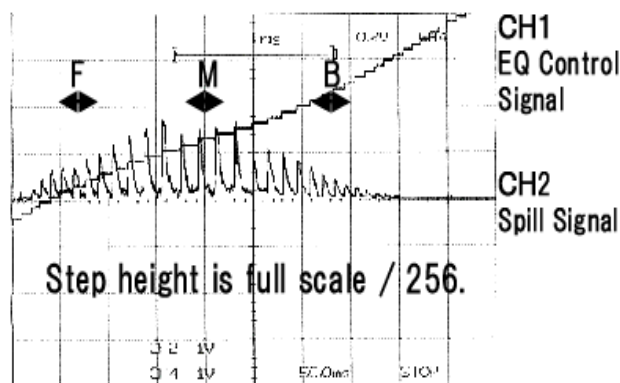

Figure 1: Response of the spill to step-like EQ current.

component of the different data of the equal group is shown in figure 2. The following were confirmed: That it causes the problem, when the frequency near 1kHz feeds back, and that the frequency fluctuates a little in the situation order.

4 FEEDBACK USING DSP

The block diagram of transfer function is shown in figure 3. The relationship between parameter ("gain", T1, T2, T3 and T4) and ripple of the spill was examined. The fact under the result was proven. The ripple of the spill decreases, when "gain" of the feedback of EQ is made to change with the time, and build-up and characteristics of the trailing edge are also improved. The ripple of the spill decreases, when the cut-off frequency of low-pass filter in the feedback of RQ was set at the frequency which was enough lower than 1kHz, when the gain of the allowances minute in 1kHz is raised. It shows the aspect of the comparison of digital feedback and analog feedback in figures 4 and figures 5. The spill is shown in the red line in figure 4, and the time change of frequency component is shown in the figure of the blue rectangle. In figure 5, the frequency component in the timing shown in the numeral of figure 4 is shown in detail. Ripple content rate in the analog feedback in being best was 11%, and the content rate of the ripple in the digital feedback in being best was 8%. By using DSP, it was possible to decrease the about 30% ripple at the ratio.

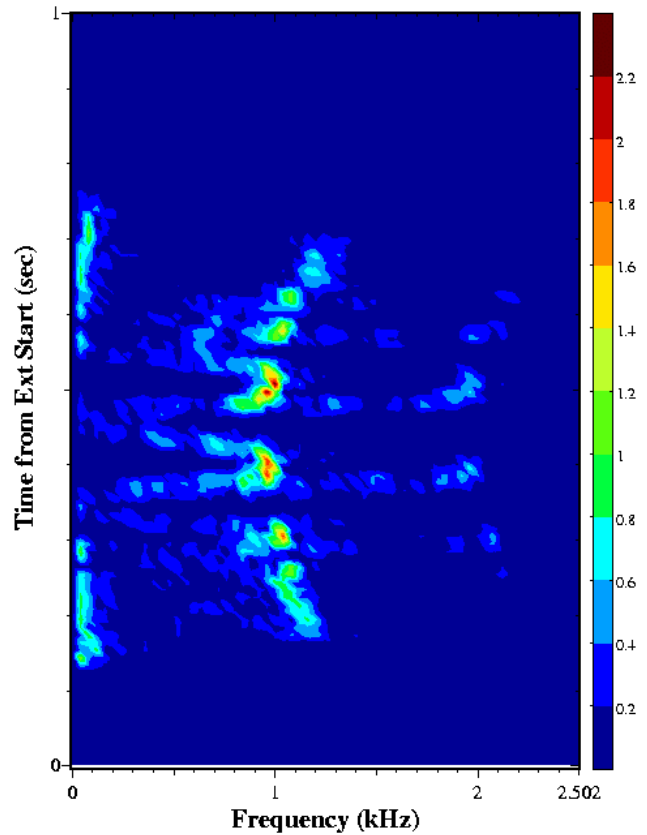

Figure 2: This extraction system has a critical frequency at about 1kHz.

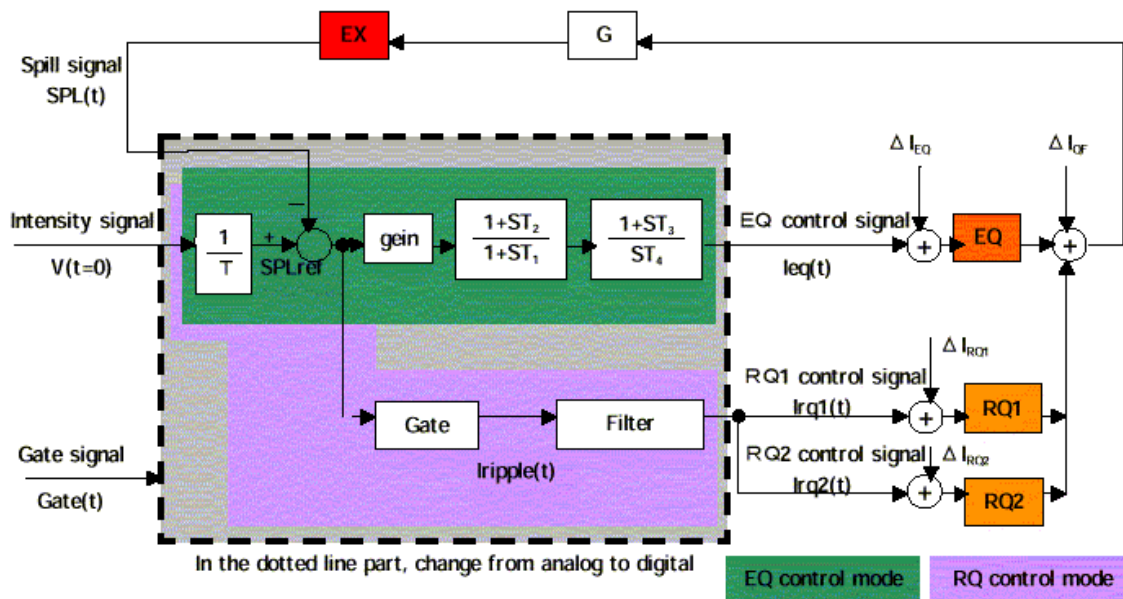

Figure 3: Block diagram of the transfer function of the feedback.

5 CONCLUSIONS

It was clear that it was sufficiently sensed in usual operation, until it can not be quantified, and that taking thing is possible, and that control variable must change for the optimum control with the time for the situation like the superscription. Then, the digital feedback using DSP was planned, and in the inside which carried out various experiments, the observation result like the superscription was obtained, and degree of proper of this planning was confirmed.

Present data though it is by the development test machine, the operability is improved, and in addition, it is developing the practical machine which can expect the improvement in characteristics.

REFERENCES

- [1] H. Nakagawa, H. Tanaka *et. al.*, "Spill Servo Control by DSP", Proc. Of the ICALEPCS99, Trieste, 293(1999).
- [2] H. Sato, T. Toyama *et. al.*, "Analysis of the Servo-Spill control for slow beam extraction", Proc. Of the 9th Symp. On Acc. Sci. & Tech, Tsukuba, 25(1993). Of the 9th Symp. On Acc. Sci. & Tech, Tsukuba, 25(1993).

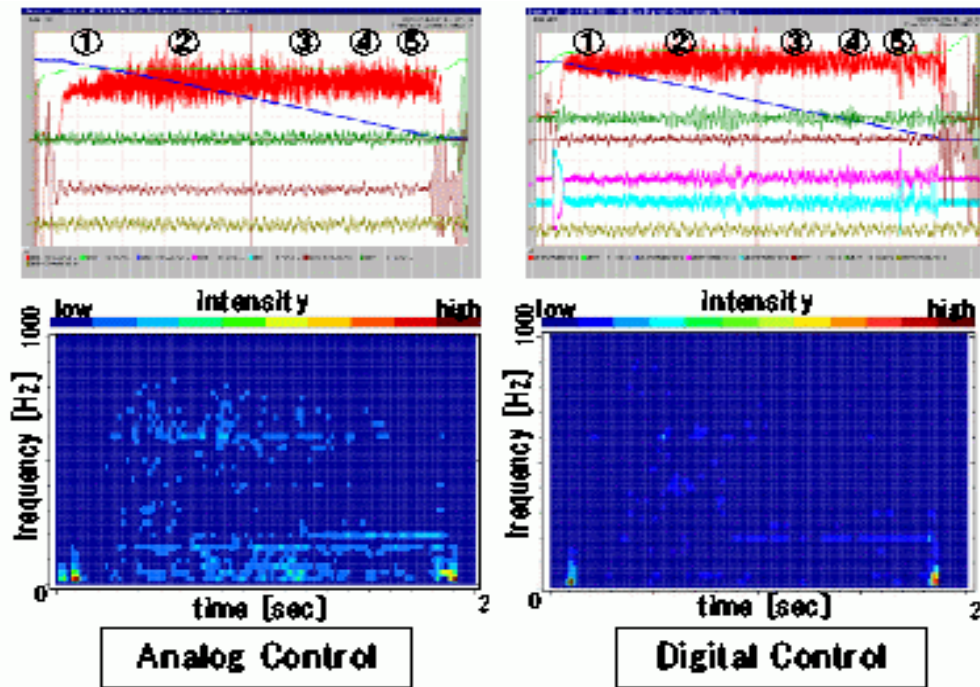

Figure 4: Comparison between the analog control and digital control. Upper: Red line shows spill signal. Lower: Frequency Analysis.

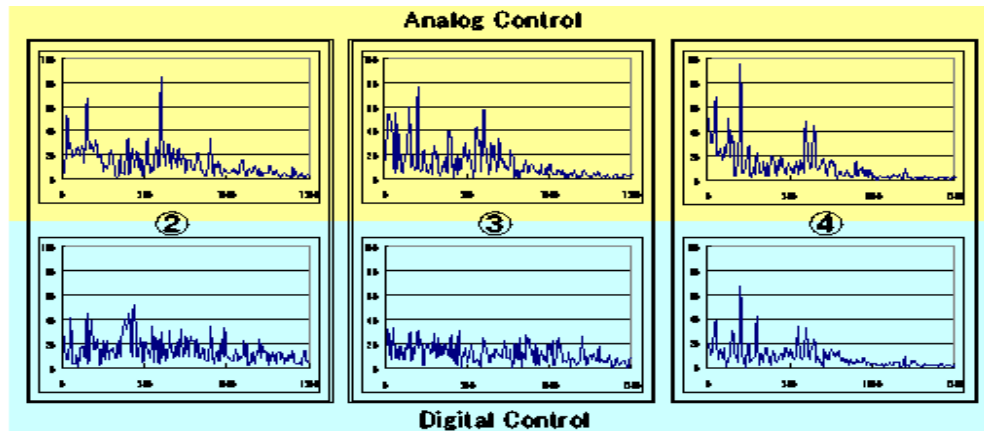

Figure 5: Frequency analysis of the spill signal. Upper: analog feedback Lower: digital feedback. Each number means the timing shown at fig. 4.