

Recent Ground Motion Studies at SLAC *

Andrei Seryi

Stanford Linear Accelerator Center, Stanford University, Stanford, California 94309 USA

Abstract

Studies of slow ground motion have recently been performed at SLAC using the linac laser alignment system over a period of one month. Two significant effects responsible for the observed motion have been identified, namely tidal forces and variation of external atmospheric pressure. The latter is of particular interest as it may result in misalignments with rather short wavelength.

1 INTRODUCTION

The electron-positron linear colliders envisioned for the future must focus the beams to nanometer beam size in order to achieve their design luminosity. Small beam sizes impose strict tolerances on the positional stability of the collider components. Ground motion will continuously change the component positions.

Specifically to linear colliders, the ground motion can be categorized into fast and slow motion. Fast ground motion (roughly $f \gtrsim 0.1\text{Hz}$) causes the beam position to change from pulse to pulse. In contrast, slow ground motion ($f \lesssim 0.1\text{ Hz}$) does not result in an offset of the beams at the interaction point since it is corrected by feedback on a pulse to pulse basis. However slow motion causes emittance dilution since it makes the beam trajectory to deviate from the ideal line. Investigations of slow ground motion are essential to determine the requirements for the feedback systems and to evaluate the residual emittance dilution due to imperfections in the feedback systems.

Investigations of slow motion of the SLAC linac tunnel, described in this paper, were performed in the framework of the Next Linear Collider [1]. The measurements were taken from December 8, 1999 to January 7, 2000. Earlier measurements using the same technique were performed at SLAC in November 1995 for a period of about 48 hours [2]. The goal of our measurements was to perform systematic studies of slow motion and to find correlations with various external parameters in order to determine the driving cause of the motion.

2 RESULTS AND DISCUSSION

The measurements of slow ground motion were performed using the SLAC linac laser alignment system [4]. This system consists of a light source, a detector, and about 300 targets, one of which is located at each point to be aligned over a total length of 3050 m. The targets are installed in a 2-foot diameter aluminum pipe which is the basic support girder for the accelerator. The target is a rectangular

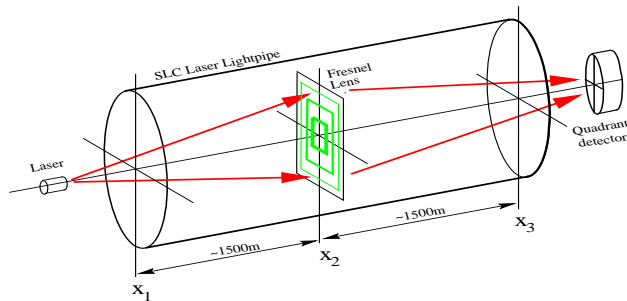

Figure 1: Schematic of the measurement setup.

Fresnel lens which has pneumatic actuators that allow each lens to be flipped in or out. The light source is a He-Ne laser shining through a pinhole diaphragm. The beam divergence is large enough to cover even nearby targets and only transverse position of the laser, but not angle, influences the image position. The lightpipe is evacuated to about 15 microns of Mercury to prevent deflection of the alignment image due to refraction in air. Sections of the lightpipe, which are about 12 meters long, are connected via bellows that allow independent motion or adjustment.

A schematic of the measurement setup is shown in Fig.1. The measurements were done with a single lens inserted which was not moved until the measurements were finished in order to ensure maximal accuracy. (In multi target mode the repeatability of the target positioning limits the accuracy). We used the lens 14-9 located at the end of the 14th sector of 30 total, almost exactly in the middle of the linac.

For these measurements, we replaced the standard detector for this system with a quadrant photodetector (produced by Hamamatsu) which has a quadratic sensitive area ($\sim 10 \times 10\text{ mm}^2$) divided into four sectors. By combining preamplified signals u_i from these quadrants, the quantity to be measured $X = x_1 + x_3 - 2x_2$ (see Fig.1) can be determined as $X \propto [(u_1 + u_2) - (u_3 + u_4)] / \sum u_i$ for both the horizontal and vertical (Y) planes. Calibration of the system was done by moving the detector transversely. The sensitivity is linear in the range of $\pm 1\text{ mm}$.

The measured data are shown in Fig.2. Two particular characteristics are clearly seen: the tidal component of the motion is very pronounced; there is a strong correlation of the motion with external atmospheric pressure.

The linac tunnel was closed, with temperature stabilized water through the RF structures during the entire period of the measurements. The girder temperature was stable within 0.1°C over a day and within a few 0.1°C over a week. The RF power was switched off starting Dec. 24 and turned on again Jan. 3. This resulted in a slow (weekly) change of the girder temperature by 0.5°C in the middle of the linac and 1.5°C at the beginning. The average external temperature varied by about 10°C over the month. No significant correlation of the measured data with these and

* Work supported by the U.S. Department of Energy, Contact Number DE-AC03-76SF00515.

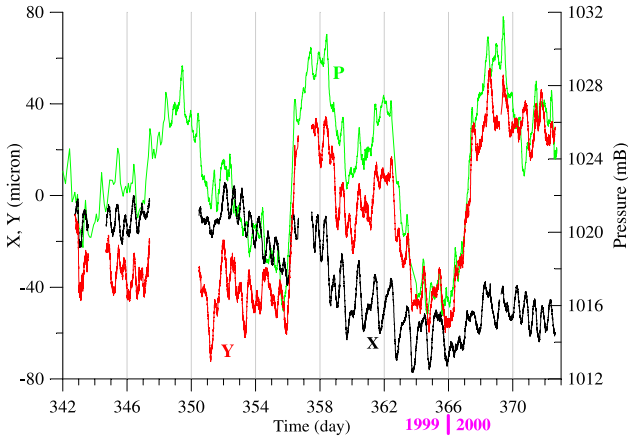

Figure 2: Measured horizontal X and vertical Y displacements plotted along with external atmospheric pressure.

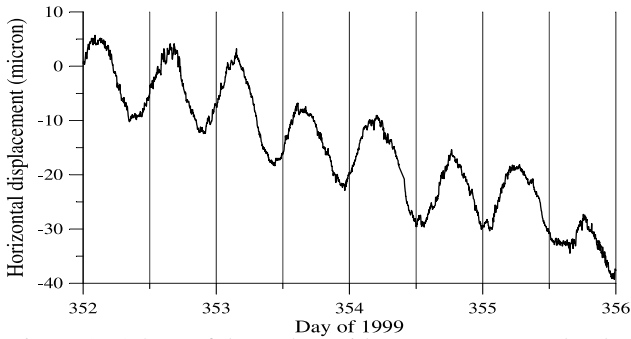

Figure 3: Subset of data where tides are seen most clearly.

other parameters was observed.

The tidal component of the motion has a surprisingly large amplitude ($\sim 10\mu\text{m}$) (see Fig.3). The most pronounced, in the measured data, harmonics are M2 (principal lunar), N2 and J1. The primary effect of tidal deformation is to change the slope of the earth's surface ($\sim 100\mu\text{m}/\text{km}$ assuming total deformation $\sim 0.5\text{m}$). The secondary effect is to change the curvature of the surface ($\sim 0.01\mu\text{m}/\text{km}^2$ if one assumes uniform earth deformation). The laser system is not sensitive to the slope change, but only to the curvature change, which is an advantage. The observed $10\mu\text{m}$ change of the curvature can only be explained if a local effect of the tides, with $R_{\text{effective}} \sim 500\text{km}$, is assumed. This local anomaly at SLAC is caused by loading on the coastline as the ocean water level varies due to the tides. This phenomenon has been known for many years and is called ocean loading. This effect is also responsible for an enhancement of the tidal variation of the earth surface slope observed in the San Francisco Bay Area [5]. The ocean loading effect vanishes away from the coastline. Regardless, these tidal effects are harmless for a linear collider, because the motion is slow, very predictable and, most importantly, has a wavelength much longer than the length of the accelerator.

Correlation of the tunnel deformation with changes of external atmospheric pressure, clearly seen in Fig.2 and 4, is significant from the lowest observed frequency up to $\sim 0.003\text{Hz}$. Above this frequency the characteristic size

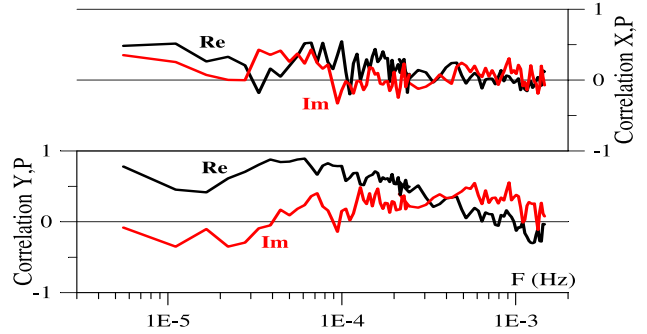

Figure 4: Correlation (real and imaginary parts) of displacement with atmospheric pressure.

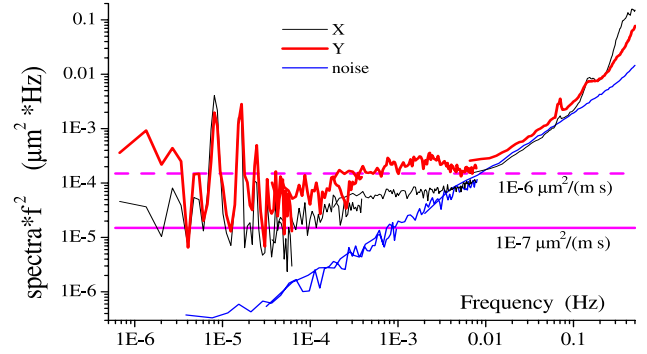

Figure 5: Spectra of displacement (multiplied by f^2) and the noise of electronics. Peaks around 10^{-5}Hz correspond to tides. Horizontal lines correspond to the ATL spectra.

over which the pressure changes, which is $\sim v_w/f$, where v_w is the wind velocity (typically 5m/s), becomes shorter than the linac length and the correlations vanish. In this frequency range, the ratio of deformation to pressure is almost constant at about $6\mu\text{m}/\text{mbar}$ in Y and $2\mu\text{m}/\text{mbar}$ in X . The influence of such global changes of pressure on the ground deformation can be explained if the landscape or the ground properties vary along the linac. One should note that deformations of the lightpipe itself or motion of the targets caused by external pressure variation appear to be eliminated by design [4].

Assuming that the Young's modulus E of the ground varies by $\Delta E/E$ over a characteristic length ℓ , or that the shape of the landscape varies such that the normal angle to the surface varies by $\Delta\alpha$, or that the characteristic depth $h \sim \ell$ (to more rigid layers) varies by $\Delta h/h$, the rough estimation of the tunnel deformation due to variation of atmospheric pressure ΔP is

$$\Delta X, Y \sim h \frac{\Delta P}{E} \cdot \left(\frac{\Delta E}{E} \text{ or } \Delta\alpha \text{ or } \frac{\Delta h}{h} \right) \quad (1)$$

The observed $\Delta h = 50\mu\text{m}$ for $\Delta P = 1000\text{Pa}$ is consistent with this estimation if $\Delta E/E \sim 0.5$, $\Delta\alpha \sim 0.5$ or $\Delta h/h \sim 0.5$. (consistent with heterogenous landscape and geology at SLAC) and if one assumes $E/h \sim 10^9\text{Pa}/100\text{m}$. The latter appears to agree well with the SLAC correlation measurements [1] where the phase velocity v as a function of frequency was found to be $v[\text{m/s}] \approx 450 + 1900 \exp(-f[\text{Hz}]/2)$. If one plots these results in terms

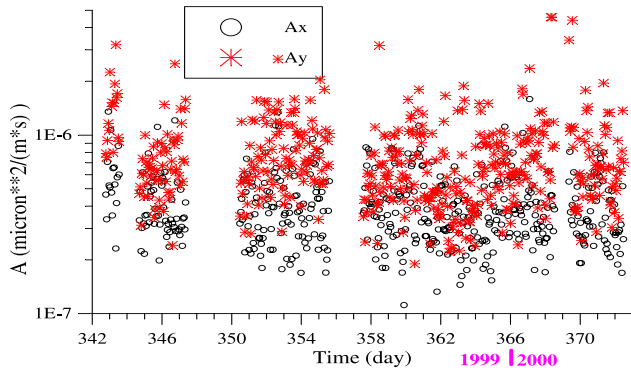

Figure 6: Parameter A defined from fit to spectra in the band $2.44E-4$ to $1.53E-2$ Hz for all data.

of the quantity v^2/λ versus λ we will see that this value is almost constant, and slowly varies from $3000\text{m/s}^2 \approx 10^9\text{Pa}/(100\text{m}\cdot 2 \cdot 1600\text{kg/m}^3)$ at $\lambda = 100\text{m}$ to $2000\text{m/s}^2 \approx 10^{10}\text{Pa}/(1000\text{m}\cdot 2 \cdot 2500\text{kg/m}^3)$ at $\lambda = 1000\text{m}$. On the other hand, if the phase velocity measured in [1] is determined by shear waves with $v_s \approx \sqrt{E/(2\rho)}$, then, assuming that $h \sim \lambda$ and that the ground density ranges from 1.6 to $2.5 \cdot 10^3\text{kg/m}^3$ and increases with depth (which is very reasonable for the SLAC geology), one can see that the ground heterogeneity can indeed be a cause of the observed pressure–deformation correlation. As we see, both short $\sim 100\text{m}$ and long $\sim 1000\text{m}$ scale can be responsible for this effect.

The spectra of the tunnel deformations exhibits $1/f^2$ behavior over a large frequency band (see Fig.5). The $1/f^2$ behavior vanishes at $f \gtrsim 0.01$ Hz where the signal to noise ratio becomes poor due to noise in the detector and electronics. Evaluation of this noise, also shown in Fig.5, has been done by means of a light source attached directly to the photodetector. The spot size and intensity of this light source were very similar to those of the laser. Influences of other sources of error (vacuum and temperature variation in the lightpipe, temperature in the tunnel, etc.) were analyzed but were found to be insignificant.

One model of slow ground motion is described by the ATL-law [3], which in spectral representation is expressed as $P(\omega, k) = \frac{4A}{\omega^2 k^2}$ or $P(\omega, L) = \frac{2AL}{\omega^2}$ (where $\omega = 2\pi f$, k is wave number, and ω and k are defined over 0 to ∞ range). For our 3 point motion, the ATL spectrum corresponding to the measured X or Y is $P(\omega) = \frac{4AL}{\omega^2}$ with $L = 1500\text{m}$. Fig.5 shows that the measured spectrum corresponds to a parameter A of about 10^{-7} – $2 \cdot 10^{-6} \mu\text{m}/(\text{m}\cdot\text{s})$ which also changes somewhat with frequency.

Spectral analysis of subsets of the data, however, shows that this parameter actually varies in time (see Fig.6). The variation of atmospheric activity is again responsible for the variation of parameter A . The spectra of pressure fluctuations was found to behave also as A_p/ω^2 and its amplitude A_p correlates with the parameter A , as seen in Fig.7. The temporal pressure variation can therefore be a major driving term of the A/ω^2 -like motion.

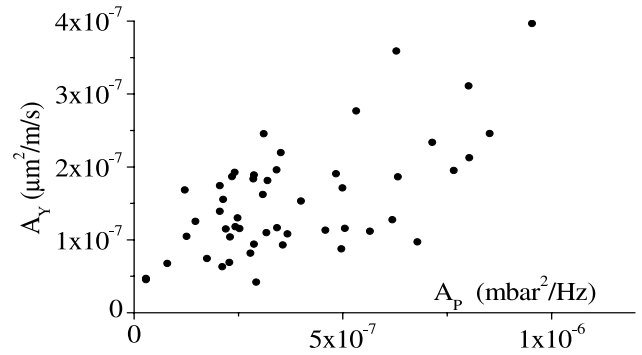

Figure 7: Parameter A_y defined from all vertical motion data in the frequency band $3 \cdot 10^{-5}$ – 10^{-3} Hz versus amplitude A_p of the atmospheric pressure spectrum.

No direct conclusions can be made from our measurements to determine the spatial behavior of the observed slow motion. However, taking into account the mechanisms of the pressure influence described above, for example the variation of the upper layer depth, and also taking into account that topology of many natural surfaces (including landscapes) exhibits $1/k^2$ behavior of the power spectra [7], one can expect that temporal pressure variation can also be a driving term of the ATL-like motion in a spatial sense. Therefore the measured parameter A can be extended to a shorter scale. The measurements performed at SLAC in the FFTB tunnel over a much shorter baselength, about 30m , found a similar value for $A \approx 3 \cdot 10^{-7} \mu\text{m}/(\text{m}\cdot\text{s})$ on a time scale of hours [6], and do not contradict this hypothesis. The atmosphere driven contribution to the parameter A scales as $1/E^2$ or as v_s^4 , as seen from Eq.1, and therefore strongly depends on geology.

3 CONCLUSION

Atmospheric pressure changes were found to be a major cause of slow motion of the shallow SLAC linac tunnel. In deep tunnels or in tunnels built in more solid ground, this mechanism would vanish, as it strongly depends on geology and location. Other sources could then dominate.

I would like to thank G.Bowden, T.King, G.Mazaheri, M.Rogers, L.Griffin, R.Ruland, R.Erickson, T.Graul, B.Herrmannsfeldt, C.Adolphsen, N.Phinney and T.Raubenheimer for help, technical assistance and valuable discussions.

4 REFERENCES

- [1] NLC ZDR Design Group, SLAC Report-474 (1996).
- [2] C. Adolphsen, G. Bowden, G. Mazaheri, in Proc. of LC97, 1997.
- [3] B.Baklakov, P.Lebedev, V.Parkhomchuk, A.Seryi, A.Sleptsov, V.Shiltsev, Tech. Phys. **38**, 894 (1993).
- [4] W. B. Herrmannsfeldt, IEEE Trans. Nucl. Sci. **12**, 9 (1965).
- [5] Milton D. Wood, Ph.D. thesis, Stanford, May 1969.
- [6] R. Assmann, C. Salsberg, C. Montag, SLAC-PUB-7303, in Proceed. of Linac 96, Geneva, (1996).
- [7] R. Sayles, T. Thomas, Nature, **271**, February 2, (1978).