

A VERSATILE EMITTANCE METER AND PROFILE MONITOR*

H.R. Kremers*, J.P.M. Beijers, S. Brandenburg, KVI, Groningen, the Netherlands

Abstract

An emittance meter has been developed to measure the full 4D phase space distribution for low energy ion beams. The instrument will be installed at different locations, where the expected shape of the phase space distribution is highly variable. To cope with these different conditions the instrument combines the pepperpot and scanning techniques. The phase space distribution is imaged on a CCD-camera using a MCP + phosphor screen combination.

In the first commissioning experiments the single ion response of the instrument has been measured and emittance measurements have been performed.

INTRODUCTION

Superconducting ECR ion sources [1] operate at fields of several Tesla, while the total extracted beam intensity is in the range 10-100 mA. Consequently, the magnetic fringe field through which the beam is extracted from the source and space charge effects will cause correlations and higher order effects to be much more important than they already are in present sources.

The intensities of highly charged heavy ion beams required for experiments at intermediate and high energy accelerators can only be met if the beams extracted from these sources can be properly matched to the acceptance of the accelerators. Consequently, detailed knowledge of the full 4D phase space distribution of the beams is essential. Therefore a 4D emittance meter has been developed in the framework of the ECR ion source development at KVI and the EU-supported ISIBHI-collaboration [2]. In order to handle widely varying shapes of the phase space distribution we use a hybrid technique consisting of a linear array of small holes in one direction and scanning in the perpendicular direction.

In this paper the details of the design and first results, focussing on the single ion response and the resolution of the instrument will be described.

EMITTANCEMETER DESIGN

The instrument should be capable to measure 4D phase space distributions with in one plane a maximal divergence of ± 50 mrad and a narrow width and in the other plane a maximal beam width of 40 mm and a small divergence. To meet these conflicting requirements a hybrid solution has been adopted, in which a linear pepperpot is used for the plane with small divergence and scanning for the other plane. In this way an acceptable accuracy is achieved for both planes. A schematic view of the instrument, indicating the main components, is shown in Fig. 1.

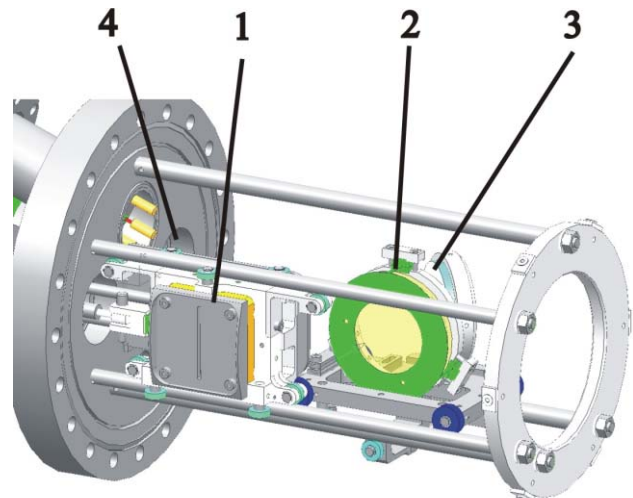

Figure 1: Layout of the emittance meter: 1) pepper plate, 2) multi channel plate, 3) mirror, 4) view port to CCD camera.

The pepperpot plate (Fig 1: 1) should be able to absorb 150 W of beam power and is therefore mounted on a water-cooled block. The pepperpot plate is a 25 μm tantalum foil with a row of 20 holes of $\text{\O} 20 \mu\text{m}$, machined by laser cutting, with a pitch of 2 mm. By changing the geometry of the hole pattern the instrument can be adapted to the expected phase space distribution.

The position sensitive detector (Fig. 1: 2) is mounted 53.8 mm downstream of the pepper plate and consists of two multi-channel plates (MCP) in chevron configuration and a phosphor screen both with an effective diameter of 41.5 mm, purchased from El-Mul. The MCP has a maximum gain of up to 5×10^7 and is capable of detecting individual ions. The decay time of the light emission of from the phosphor screen is 1.2 ms. The 2D light-intensity distribution from the phosphor screen is imaged with a mirror ($\text{\O} 50$ mm) (Fig.1: 3) and a lens system (PENTAX C2514M) onto a CCD camera mounted outside the vacuum (Fig.1: 4). The whole system is bakeable and suitable to operate in a 10^{-9} mbar vacuum.

The optical transmission from the phosphor screen to the CCD was found to have a slight position dependence, which is easily corrected by incorporating a digital filter in the analysis software. The SONY XCL-U1000 CCD camera has 1600×1200 pixels of $4.4 \times 4.4 \mu\text{m}$ and is capable of taking 15 frames per second. The shutter time can be varied from 0.07 to 10^{-4} s.

The MCP, phosphor screen and mirror are mounted on a table which can be moved in and out of the beam. The pepperpot plate is also moved through the beam by a servo-controlled translation mechanism. The positioning accuracy of this mechanism is better than $10 \mu\text{m}$, the minimum displacement is $10 \mu\text{m}$.

COMMISSIONING EXPERIMENTS

The initial commissioning of the emittance meter has been performed at the injection beam line of the AGOR facility at KVI using heavy-ion beams produced with the KVI-AECR ion source [3]. First measurements of the single-ion response of the emittance meter are presented, followed by an initial measurement of the (partial) emittance.

Single-Ion Response

The single-ion response of the MCP + phosphor screen determines the ultimate angular resolution that can be reached, independent of the geometrical dimensions and the imaging system. The single-ion response has been determined using a very low-intensity, defocused beam of O^{7+} ions impinging on a 1 mm diaphragm placed in front of the MCP. The light from the phosphor screen is focused onto the CCD camera with a single lens with magnification $M = 0.28$. The CCD shutter time was set at a value of 35 ms. The ion flux incident on the MCP was determined by measuring the MCP count rate. Rates down to 100 s^{-1} were easily produced.

Figure 2 shows a CCD image of an 84 keV O^{7+} beam at a count rate of 400 s^{-1} . Individual ion impacts can easily be distinguished. This is shown more clearly in Fig. 3 where an intensity distribution is plotted of six ions hitting the MCP along the vertical line indicated in Fig. 2. As can be seen the single-ion responses can easily be fitted with Gaussians, whose positions are determined with a standard deviation of 2 pixels. The 3σ accuracy of the impact location of an ion hitting the MCP corresponds to a spatial uncertainty of $\sim 100 \mu\text{m}$ on the phosphor screen. The spatial binning of the imaging optics is $44 \mu\text{m}$, which thus is not a limiting factor for the intrinsic spatial resolution. The corresponding angular resolution is 1.9 mrad.

It should be pointed out that the sampling, i.e. 2 mm in the one direction and the step size used in the other direction determines the resolving power of the spatial intensity distribution in the beam.

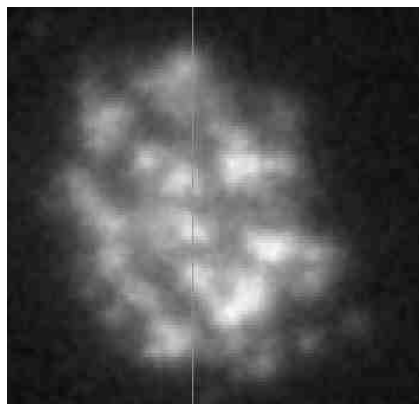

Figure 2: CCD image of 87 keV O^{7+} ions at a MCP count rate of 400 s^{-1} .

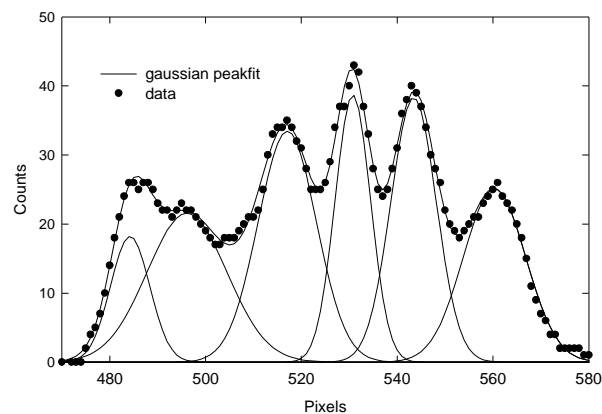

Figure 3: Intensity distribution along the vertical line indicated in Fig. 2.

First Emittance Measurements

Emittance measurements were made with an 84 keV Ne^{7+} beam of $6 \mu\text{A}$. The individual beamlets exiting from $\varnothing 20 \mu\text{m}$ holes have an intensity in the order of 10 pA. Figure 4 shows the image of the transmitted beamlets on the phosphor screen as read out by a LabVIEW application together with the location of the holes. The individual beamlets are clearly separated. The image clearly shows a correlation between Y and X' , which can not be detected with Allison-type scanners.

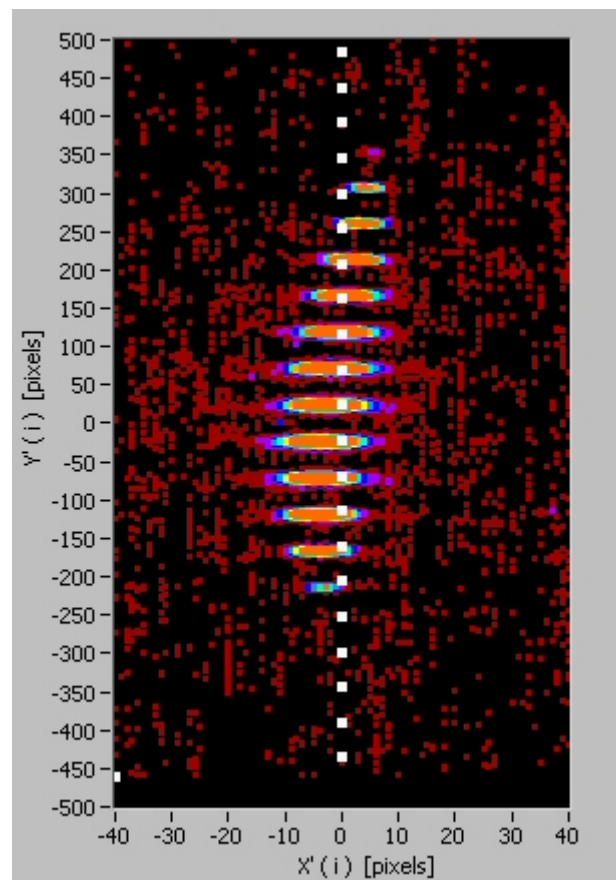

Figure 4: 2D Profile of a 12 kV O^{+7} beam.

The magnification of the optical system was determined by imaging the pepperpot plate, located at the position of the phosphor screen, onto the CCD camera. The measured value ($M = 0.1$) is in very good agreement with the manufacturer specifications.

The projection of the phase space distribution on the Y - Y' plane is constructed by associating a range of horizontal rows with each hole and summing over each row (\equiv integration over X') and summing over the images for different horizontal positions of the pepperpot plate (\equiv integration over X). The CCD noise is eliminated by neglecting pixels with a collected charge below a preset value. In Fig. 5 the Y - Y' distribution for a single image (at $X = 0$) and a single column centred at $X' = 0$ for the image of Fig. 4 is displayed.

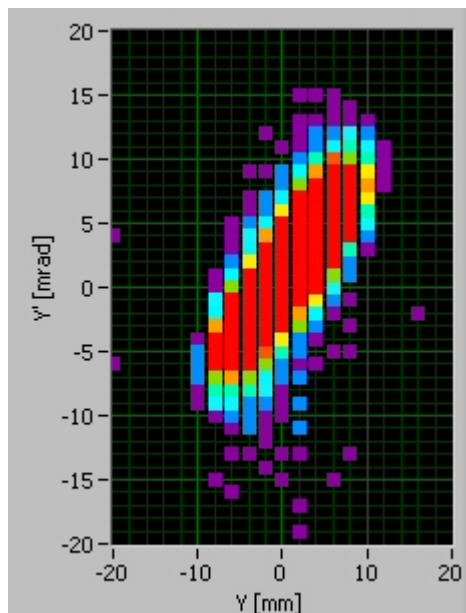

Figure 5: Y - Y' distribution for $X=0$; $X'=0$ of the image shown in Fig. 4.

CONCLUSIONS AND OUTLOOK

An emittance measuring device aiming at determining the full 4D phase space distribution of low energy ion beams has been designed and constructed. First measurements have shown that the angular resolution of the instrument is dominated by the single ion response and amounts to 1.9 mrad, in agreement with the design objectives. The spatial resolution in both X and Y is determined by the sampling pitch. By exchanging the pepperpot plate the instrument can be easily adapted to varying experimental conditions.

The algorithm to extract the data needed to construct the Y and Y' intensity distributions has been successfully tested. The analysis software to extract the full 4D phase space distribution from the data and to determine the various dimensions and correlations is presently under development.

To complete the calibration measurements of the relative area of the holes in the pepperpot plate and the position dependence of the light yield of the phosphor screen still have to be performed. Furthermore the measured transmission of the imaging system has to be verified against simulations also taking into account polarization effects.

Furthermore, the behaviour at high beam intensities (e.g. sputtering of the pepperpot plate, degradation of the MCP and phosphor screen performance) requires further investigation.

REFERENCES

- [1] D. Leitner *et al.*, Nucl. Instr. Meth. B **235**(2005)486
L.T. Sun *et al.*, Nucl. Instr. Meth. B **235**(2005)524
S. Gammino, Rev. Sci. Instr. **72**(2001)4090
P.A. Zavodsky *et al.*, Nucl. Instr. Meth. B **241**(2005)959.
- [2] G. Ciavola *et al.*, Rev. Sci. Instrum. **77**, 03A303 (2006).
- [3] H.R. Kremers, J.P.M. Beijers and S. Brandenburg, Rev. Sci. Instrum. **77**, 03A311 (2006).

ACKNOWLEDGEMENTS

This work has been performed as part of the research programme of the "Stichting voor Fundamenteel Onderzoek der Materie" (FOM), with support of the "Nederlandse Organisatie voor Wetenschappelijk Onderzoek" (NWO).

It has been supported by the Rijks Universiteit Groningen (RuG), the Gesellschaft für Schwerionenforschung mbH and the European Commission through the EURONS-I3 (European Commission Contract No. 506065).