

THE NEW DIODE BPM SYSTEM FOR ELETTRA

R. De Monte, Sincrotrone Trieste SCpA, Trieste, Italy

Abstract

A new Beam Position Monitor system has been developed at ELETTRA based on an envelope detector. It is a four channel system reading in parallel the four voltages from a button pick-up that adopts a wide-band Schottky diode. The analogue bandwidth of the currently implemented detector is less than 1 kHz which has been adapted to the present application of the system, i.e. a fast beam position interlock to be installed on the ELETTRA storage ring.

The upgrade of the ELETTRA BPM which is based on the Libera detector suggested us to add some redundancy on the fast position interlock in order to protect the vacuum chamber from wrong positions / angles of the beam. The data collection scheme, based on a single board computer for each straight section, is presented. Currently, the system has been installed and tested on all the ELETTRA undulator sections; the first running experience is here presented.

THE HARDWARE

The main purpose of the system is the real time acquisition and comparison of two BPM readings, the ones upstream and downstream the ID straight, to prevent the overheating of the Elettra front ends vacuum chamber due to wrong beam trajectories. It is running in parallel with the close orbit BPM detector (Libera).

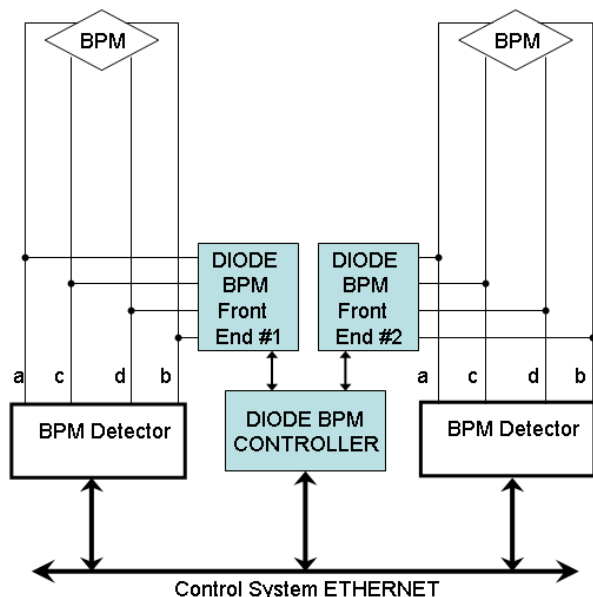

The Front End electronics is closed to main signal cables. It is connected with a 'T' connector to maintain the insertion loss as low as possible. The total signal loss for the BPM detector when the DIODE BPM Front End is connected is 5% of the total signal. The wide-band

Schottky diode used in the front end is few millimetres away from the connector to keep RF reflections at a minimum level.

The Front End board

The Front End simplified schematics is shown in the figure above and represent one of the four channels of one Front End Board.

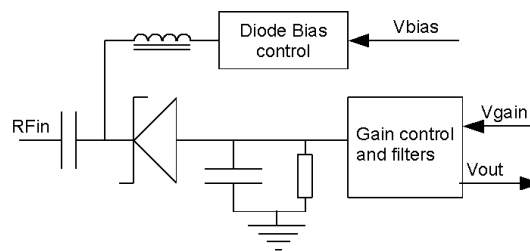

“Vgain” is software controlled using a single 12 bit DAC fitted to the DiodeBPM controller, common for the four channels. ‘Vbias’ is software managed using a 4 channel 16bit high precision DAC available on the Front End board. All the signal conditioning is performed by ultra low noise operational amplifiers to keep the total noise as low as possible.

The frequency range of these inputs goes from 100MHz to 800MHz. The upper bandwidth is limited by the cable capacitance whose length has been kept at a minimum to reach optimum performances. On the Elettra installation, the mean values of the rectified signal are listed in table 1.

mA	15m cable	25m cable
300	700 mV	450 mV
200	480 mV	300 mV
100	200 mV	130 mV
75	140 mV	80 mV

table1

The two front ends are linked to the Diode Bpm Controller via two flat cables. The RC filters after the diodes assures a flat response up to 1KHz. The subsequent filters, have a cut-off frequency of 300Hz; these low values are used to avoid any interference with an RF multiplexer present on the BPM detector connected on the same cables that in our case are 8 KHz of Libera Detectors.

The Controller board

The simplified block diagram of the Controller is shown on the figure above:

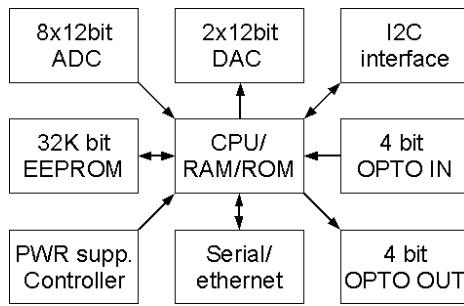

The CPU is an Analog Devices 80C51-compatible ADuC812 microcontroller. It runs at 11MHz without operating system. The communication with the Elettra Control System Network is granted by a Lantronix serial to Ethernet adapter, “transparent” towards the CPU serial port. There are also 4 bits of opto-coupled inputs and 4 bits of opto-coupled outputs. In Elettra implementation these I/O are connected with a PLC that is super visioning the undulator status and the Elettra machine current. One of these opto-coupled outputs is linked to the ‘Beam Kill’ signal. The 32kbit EEPROM is used to store calibration data concerning the two associated Front Ends. The I2C bus is used to communicate with the remote quadruple 16 bit DACS that resides on the Front End and that provide very accurate biasing for the Schottky diodes.

THE SOFTWARE

The CPU is an 8 bit single chip microcontroller @11MHz. It has 128KB RAM and 128KBFLASH ROM. The software is written in ‘C’ language. The software is structured in a way to be very deterministic. In fact all of the main tasks are done in an InterruptServiceRoutine (ISR) waked up by a timer. The commands received by the CPU via the serial/Ethernet link are processed at very low priority, and is not possible that any command stop the acquisition.

The main software tasks are: 8 ADC reading, automatic gain control, position computation using offsets and lookup table coefficients, limits and in undulator beam trajectory computation. All of the calculi are in integer, so internally the algorithms perform some multiplications and divisions by 1000 for precision purposes.

ADC reading

An internal timer is programmed to start acquisition of the eight 12 bit ADC’s at 10Hz. After the acquisition starts, four values for every channel are stored and used to make a mean to increase the signal/noise margin. When the mean is computed, the other tasks in the ISR routine are executed.

Automatic Gain Control

When the mean data from ADC are available, the Automatic Gain Control routine is executed to check the levels. The routine maintain the ADC values at 85% of the ADC capability + 5%, driving the two DACS, one for each Front End. The routine compute also a correction

factor for the absolute signal values used to compute the position. The formula used is:

$$\text{delta_agc} = (\text{ActDAC} - \text{DefltDAC}) * \text{DAC_gain}$$

where ActDAC is the actual applied DAC value, DefltDAC is the DAC value to read 0 with no signals and DAC_gain is a number derived from the operational amplifiers gain that is in our case is 3.7. As result, we will have the four electrodes values that are in range 0-8000 from a zero signal to full signal accepted by the system (1500mV).

Calibration factors and lookup table

The Schottky diodes have no linear response with signals. For that reason, a laboratory calibration is made to linearize the response of the diodes versus the signal input. From this calibration, performed putting a known source, a lookup table is obtained. This is a graphical representation of one of them:

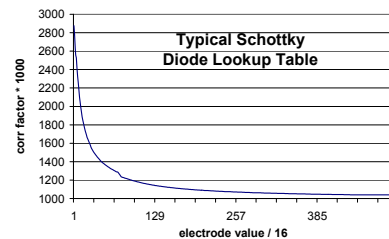

The values are stored in the EEPROM and are common for 4 electrodes of every Front End.

Other calibration factors calculated in laboratory and stored in the EEPROM are:

- The 4 values of the 16bit DAC to maintain every Schottky diode with a same bias current that correspond at 500mV in the rectified point.
- The AGC DAC value to read 0 with no input signal
- The four little offsets to read 0 on every electrode (Za,Zb,Zc,and Zd). This value is subtracted to any ADC read value: the values are in example -7 -21 -30 -15 and are generated by little differences in gain control and filters block.
- The four multiplication factors to read the same value on the four channels at full signal input MFa,MFb,MFc,and MFd.

Position Computation

The position routine applies all of the calibration coefficients, and applies different correction factors every 16 units according the Lookup Table. To compute the X and Y position the standard formula for rhomboidal BPM is used:

$$X = X_COEFF \frac{(Va+Vd)-(Vb+Vc)}{Va+Vb+Vc+Vd}$$

$$Y = Y_COEFF \frac{(Va+Vb)-(Vc+Vd)}{Va+Vb+Vc+Vd}$$

Where: $V_x = (V_{\text{meanADC}} - \text{delta_agc} - Z_x) * MF_x$

The position is computed synchronously and a circular buffer with the last 200 values is saved, ready to be read by control system as all other operating parameters.

An additional task is also performed once the position is computed: an orbit trajectory is calculated in order to protect the vacuum chamber and if the position is considered dangerous, a signal is generated on one of the opto-coupled outputs to dump the beam.

THE RESULTS

Actually 12 DIODE BPM SYSTEM is installed and is operating in the Elettra Storage Ring.

The on field performances with 50-400mA machine current, 20mm vacuum chamber, a stable beam are:

- RMS uncertainty : max 40µm min 15µm
- 8-hour stability : max 50µm

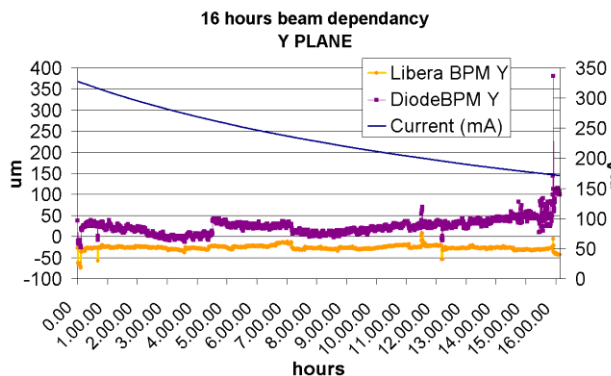
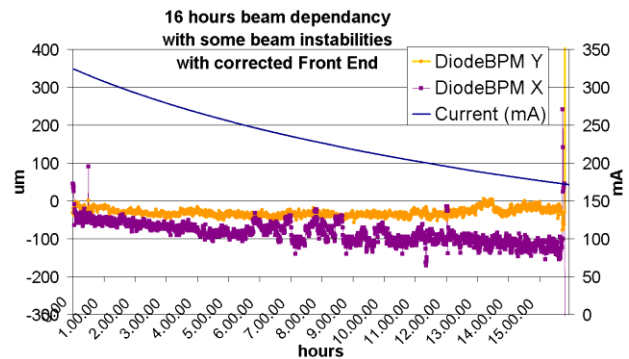
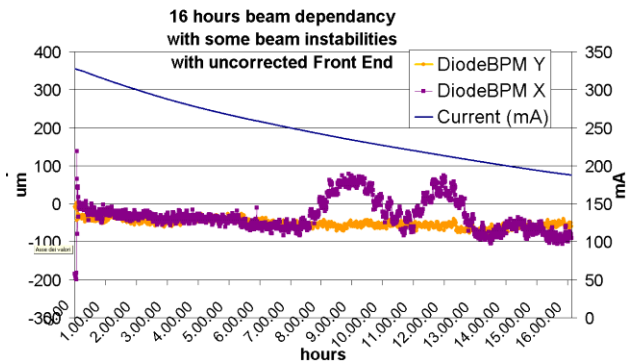
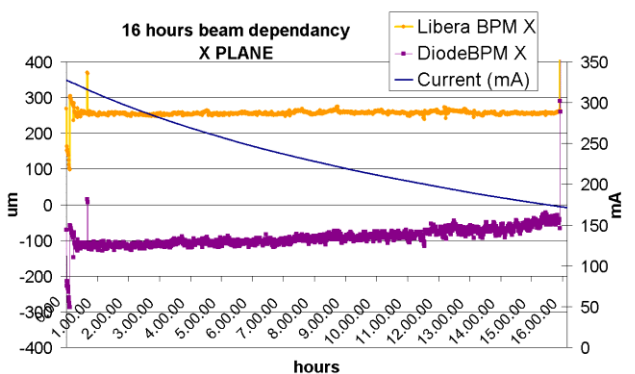

On the Y plane graph is possible to observe a local orbit correction software effects.

THE CORRECTIONS

The big disadvantage of the direct diode detection is the wider bandwidth. That gives the position computation affected by higher modes instability of the machine. This happens because the four input stages react slightly differently one to each other at different frequencies, due to mechanical/component tolerances. A good solution has been found and consists to:

- use diodes, capacitors, resistors of the input stage from the same series/lot/production

- mount the input stage with very low on soldering
 - clean very carefully from every soldering residual
- With these tricks we reach a maximum of 5% of position reading mismatches for an ‘in centre’ beam from 400 to 800MHz. The effects are visible in the acquired on field graphs above:

CONCLUSIONS

The system is installed and operating on all Elettra’s BPM that are around the undulators. It has detected some wrong orbit values and it has generated the appropriate Beam Dump signal to prevent vacuum chamber damages. During the system’s commissioning few spurious beam dump has been generated due to electronic lacks.

ACKNOWLEDGEMENTS

We would like to thank V. Forchi and M. Lonza for their help throughout the on field installation of the system, integrating it into the Elettra’s Control System.

REFERENCES

- [1] M. Lonza et al.: “BPM detectors upgrade for the ELETTRA Fast Orbit Feedback”, DIPAC2007
- [2] M. Gasior, R. Jones, ”High sensitivity tune measurement by direct diode detection”, DIPAC’05