

METHODS OF COMPENSATION OF THE BEAM VERTICAL DIVERGENCE AT THE EXIT OF SPIRAL INFLECTOR IN CYCLOTRONS

I.A.Ivanenko, JINR, Dubna, 141980, Russia

Abstract

While the axial injection into the cyclotron, the beam is turned from axial direction into median plane by means of inflector. Commonly used type of inflector is an electrostatic spiral inflector. The spiral inflector is easy to handle and has a good beam transmission factor. On the other hand, the negative feature of spiral inflector is the beam vertical divergence at its exit. It leads to increasing of beam vertical dimension and aperture losses at the first orbits. The methods of compensation of the beam vertical divergence at the inflector exit are considered at present report. These methods are used at FLNR JINR cyclotrons and give good results in transmission factor, beam quality and operation modes.

INTRODUCTION

The axial injection systems of FLNR cyclotrons (U400, U400M, IC100, DC280) are equipped by spiral deflectors. The calculations and exploitation experience show the aperture losses in the cyclotron centre because of the beam vertical divergence at the inflector exit. It not only worsens the beam intensity and quality, but decreases the inflector operation time.

The beam vertical divergence at the inflector exit appears because the ions, shifted from the central ion trajectory, have the different length of the paths inside the inflector and so spend a different time in the inflector electric field. It leads to the difference in the rotation angles of the ions. The ions with initial shifting towards the cyclotron centre, $-h$ start position at the Figure 1, have a smallest length of the path and receive incomplete rotation angles, less than 90° . And vice versa, the ions with $+h$ shifting at the start position receive rotation angle more than 90° . The farther ion is shifted from the central trajectory, the more this angular difference.

The calculations have shown that this effect is stronger for the ions, shifted along the transverse, median axis h at the inflector entrance and not so actual for shifting in vertical, u axis direction.

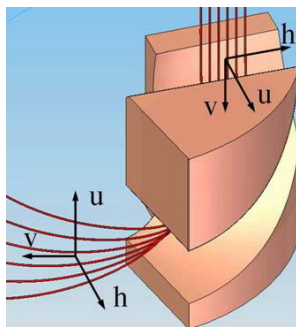

Figure 1: The computer model of spiral inflector and trajectories of ions with initial shifting along axis h .

The beam behaviour at the inflector exit was investigated by calculations and experiments for U400 cyclotron. It was found that the beam after inflection has a strong vertical divergence, that leads to aperture losses at the inflector box and dees noses, Figure 2. The experimental beam track was received on thermo-sensitive film at the first accelerating gap window. This situation is typical for cyclotrons, equipped with spiral inflector.

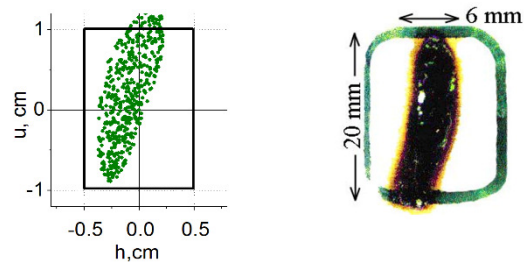

Figure 2: The calculation and experimental results - beam track at U400 first accelerating gap window.

There are some methods of decreasing of the beam vertical divergence after spiral inflector. Usually to produce vertical focusing of the beam, the additional correcting element is placed between the inflector exit and the first accelerating gap. Such element could be either the passive magnetic channel [1] or the electrostatic quadrupole lens [2]. Unfortunately, the additional correcting elements need special place for installation at the cyclotron centre and it could be a problem especially for compact cyclotrons. Another method, used at FLNR cyclotrons, is a special form of the inflector electrodes, which produces the electric field with focusing effect [3].

PASSIVE MAGNETIC CHANNEL

First efforts to solve the problem of beam vertical divergence after inflector were undertaken for U400 cyclotron. Because the very intensive physical program, about 7000h/year and a short cyclotron maintains time, the installation of passive magnetic channel was chosen [4]. It took not much time and reconstruction efforts. The iron pieces of channel were installed inside inflector box, which could be easily extracted from vacuum chamber.

Passive magnetic channel provides the local gradient of the magnetic field about 4kGs/cm along 25mm of the beam path between the inflector exit and the first accelerating gap. At this distance, the beam is focused vertically and is defocused horizontally. The horizontal divergence is not strong because, as a rule, the beam at the spiral inflector exit has a constriction point in horizontal, h axis direction. Because a very intensive energy growth, provided by 4 dees with 130kV of RF, the accelerated beam don't "feel" magnetic field perturbation beyond the magnetic channel.

The installation of passive magnetic channel provides the reduction of beam vertical dimension before first accelerating gap, compare Figures 2 and 3. The experimental results shown the increasing of transition factor at the cyclotron output from 7±9% up to 10±12%. The time between the maintenance of spiral inflector was increased from 3 month up to 9 month.

The stationary placing of the passive magnetic channel inside the inflector box is a disadvantage of this method. When the inflector azimuthal position is changed, the radial positions of the beam and magnetic channel could mismatch. Probably, this situation we see at the Figure 3.

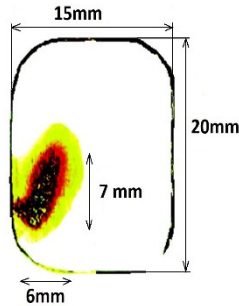

Figure 3: The beam track at U400 first accelerating gap window after passive magnetic channel installation.

ELECTROSTATIC QUADRUPOLE LENS

Now the activities on creation of the new heavy-ion isochronous cyclotron DC280 are carried out at FLNR. The isochronous cyclotron DC-280 will produce accelerated beam of ions with $A/Z=4-7$ to energy $W=4-8$ MeV/n and intensity up to 10 μA (for 48Ca).

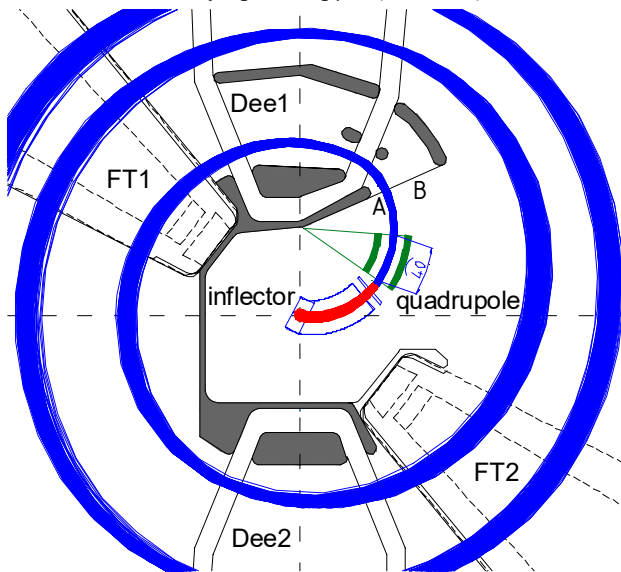

Figure 4: The central region of DC280 cyclotron. Inflector of 7.5 cm magnetic radius is placed.

Because of a wide range of operation modes, the electrostatic quadrupole lens was chosen as a focusing element. Quadrupole lens places between the inflector exit and first accelerating gap and provides the operative smooth correction of the injected beam. It could be uses

not only for beam focusing, but also as a steering to adjust the beam position at the first accelerating gap.

DC280 quadrupole lens has aperture 22mm and length 40mm along the central ion trajectory. The quadrupole electrodes repeat the form of the beam trajectory, Figures 4 and 5, and have a potential up to ± 3 kV. Four power sources provide the potential for each electrode separately to use the lens as a steering.

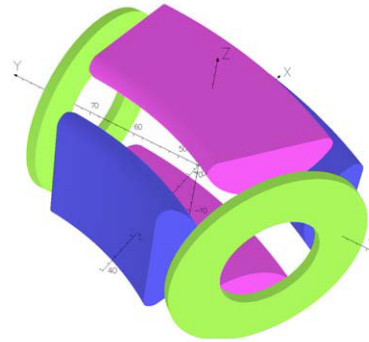

Figure 5: Computer model of quadrupole lens.

The quadrupole lens is a part of the inflector block and is rigidly attached to inflector. The inflector block could be placed into the cyclotron centre operatively by the radial directed rod through the vacuum gateway. The mechanism of the inflector block provides smooth azimuthal and radial tuning of inflector and quadrupole position. To cover the wide range of operation modes of DC280 cyclotron, two inflector blocks with magnetic radiuses 75mm, position A, and 92mm, position B, will be used, see Figure 4.

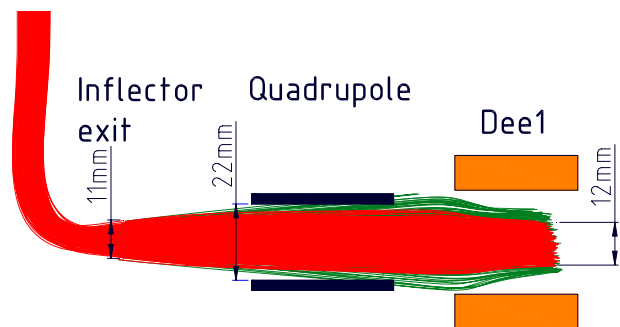

Figure 6: Beam trajectory through inflector, quadrupole and first dee puller when quadrupole is turned on or off.

The calculations show what the beam transition factor from inflector exit to the cyclotron extraction radius is about 75%, when the quadrupole lens is uninstalled. The main losses take place at the first orbits in the cyclotron center because the high amplitude of the beam vertical oscillations. The installation of electrostatic quadrupole lens decrease the beam vertical divergence after the inflector exit, Figure 6. As a result, the amplitude of beam vertical oscillations along acceleration is decreased too. On the over hand, the beam gets a small growth of amplitude of radial oscillations. Nevertheless, the summary result shows the increasing of transition factor along acceleration up to about 98 %.

INFLECTOR WITH SPECIAL FORM OF ELECTRODES

As it mentioned before, the installation of the passive magnetic channel at U400 cyclotron has some disadvantage – its stationary placing inside the inflector box. Unfortunately, the exchanging of magnetic channel on quadrupole lens at the operated cyclotron has technological problems. Another way to solve this problem is finding the method to affect to the beam when it passes through the inflector.

The numerical studies of the beam transition through spiral inflector show the possibility of compensation of the beam vertical divergence by means of special form of the inflector electric field. Such electric field not only bends the beam from the axial direction into the cyclotron median plane, but provides the focusing of the beam inside the inflector. To achieve it the additional, transverse component of the electric field is used.

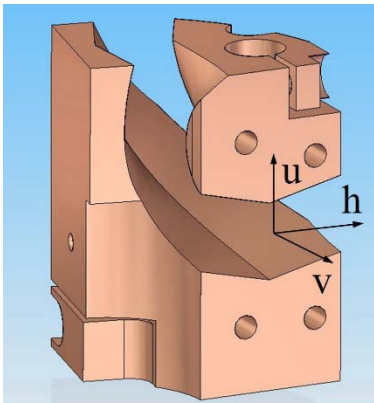

Figure 7: The new form of electrodes of U400 inflector.

This component is directed along transverse h -axis to the central ion trajectory and focuses the beam in h axis direction inside the inflector. At this case, the beam ions move closer to the central ion trajectory. It leads to decreasing of dispersion of the ions path length in the inflector electric field and, accordingly, to decreasing of dispersion of ions rotation angle in the vertical direction. Summary, the vertical beam dimension at inflector exit is decreased and the problem of aperture beam losses at the first accelerating gap is eliminated. The efficiency of this method depends on the depth of the electrodes profiling. It was found that the optimal depth of electrodes profiling for U400 inflector is 2.5mm. Of course, the beam after inflection gets a small radial defocusing, but calculations showed that this negative effect not so relevant for the beam motion, and latest experiments confirm it, Figure 8.

The spiral inflector with profiled form of electrodes were manufactured and placed into U400 cyclotron centre. The electric and magnetic radiuses of the new inflector are the same as for “classic” inflector and the old electrodes just were replaced with the new one.

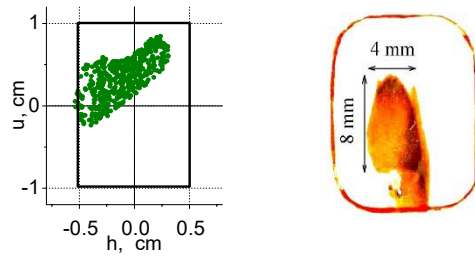

Figure 8: The calculation and experimental results - beam track at U400 first accelerating gap window. Inflector with special form electrodes is installed.

Figures 2 and 8 present the comparison of calculated and experimental beam tracks at U400 first accelerating gap window before and after installation of the new inflector. The experimental results with new inflector shown the increasing of the beam intensity at about 30%. It could be mentioned what the operation with new inflector makes the operative tuning of U400 cyclotron much easier and quicker.

SUMMARY

Different methods of compensation of the beam vertical divergence at the spiral inflector exit were used at FLNR new and operated cyclotrons. The calculations and experimental results showed a high efficiency of this compensation in increasing of the beam intensity. The choice of the method is dependent on constructive and operational features of cyclotrons.

ACKNOWLEDGEMENT

Special thanks to Frederic Chautard and Alain Savalle, GANIL, for useful recommendations and help in design of quadrupole lens for DC280 cyclotron.

REFERENCES

- [1] G. Gulbekian, I. Ivanenko, I. Kalagin, A. Morduev, “The compensation of beam vertical defocusing after the spiral inflector by using the passive magnetic channel”, in *Proceedings of the 7th European Particle Accelerator Conference (EPAC’00)*, 24 – 28 June 2000, Vienna, p.p. 1504 – 1506.
- [2] M. Lieuvain *et al.*, “Commissioning of Spiral, the GANIL radioactive beam facility”, in *Proceedings of the 16th Conference on Cyclotrons and Their Applications*, 13 – 17 May 2001, Michigan, USA, p.p. 59 – 63.
- [3] B. N. Gikal, G. G. Gulbekian, I. A. Ivanenko, “U400 Cyclotron Spiral Inflector with Beam Vertical Focusing Effect”, in *Proceedings of the 1th International Particle Accelerator Conference (IPAC’10)*, 23 – 28 May 2010, Kyoto, Japan.
- [4] G. Bellomo, “Design of passive magnetic channels”, in *Proceedings of the 13th Conference on Cyclotrons and Their Applications*, pp. 592 – 595.