

OVERVIEW OF RECENT HALO DIAGNOSIS AND NON-DESTRUCTIVE BEAM PROFILE MONITORING

K. Wittenburg, DESY, Hamburg, Germany

Abstract

Beam profile (emittance) and beam halo are characteristic properties of high-intensity and high energy beams that might limit the performance of the accelerator. Therefore a reliable measurement and determination of these parameters is most helpful for the understanding, tuning and improvement of the whole accelerator chain to achieve the best (at least the design-) performance. This talk will give an overview over recent instruments used for non-destructive beam profile and halo monitoring and will discuss their limits, experiences and latest improvements.

INTRODUCTION

Non destructive beam profile measurements of the beam core for emittance determination and the determination of the beam halo are crucial for any high intensity and high energy accelerator, both for beam dynamic studies and for low beam losses during acceleration and store. The boundary between beam profile and beam halo is somewhat diffuse and the definition of “beam halo” depends on your point of views [1]. In this report I will use the diagnostics point of view of halo, which means, by definition, low density and therefore difficult to measure. This “recent” overview covers the period between the HALO03 workshop and now [2]. It discusses two types of halo, the transversal and the longitudinal halo. Transversal monitors discussed (profile and halo) are:

- IPM (Ionization Beam Profile Monitor)
- LPM (Luminescence Beam Profile Monitor)
- Laser Wire Scanner
- Beam Probe Scanner
- Wire Scanner
- Synchrotron Radiation Monitor

The instruments for measuring the longitudinal halo (coasting beam and “beam in gap”) use the:

- Temporal Loss Distribution
- Synchrotron Radiation
- Residual Gas Ionization.

This overview will not cover topics like halo formation diagnostics (tune, chromaticity, coupling, injection mismatch, etc), destructive diagnostic (screen, grids, scrapers, ...) or the data treatment (data acquisition, fits,...).

TRANSVERSAL INSTRUMENTS

Ionization Beam Profile Monitor (IPM)^[i]

At Fermilab a new IPM was developed for the Tevatron with a 60 ns time resolution to separate the p and pbar bunches [3]. This was achieved by using the DAQ

expertise from collider detectors by selecting a chip for the front end electronics which was designed for the CMS experiment at CERN. It has a high resolution, sensitivity down to 1 fC and a very large dynamic range. Together with a MCP gain of about 10^4 , this enables single-electron sensitivity and very short integration times. The anode stripes are well shielded to decrease the sensitivity to RF noise.

The background and noise conditions of the IPM at RHIC were significantly improved by using a similar Faraday cage around the collection circuits [4]. In both cases a controlled gas leak is necessary to enhance the signal strength to archive the single turn resolution.

A turn by turn readout of an IPM is also under development at GSI, using fast optical readout with a photodiode array and a multi anode PMT [5]. Additionally a tungsten filament module was developed to monitor the well known non homogeneous aging of the MCP. Wires were meandered with 3 mm spacing, generating a known electron emission pattern when heated by a current. This can be used to keep the correction function of the MCP always up to date.

The same purpose is behind the so called Electron Generator Plate (EGP) produced by Burle, Inc. in the CERN IPM. [6]. Such an EGP is specified to emit homogeneously electrons covering the complete area of the MCPs used in the IPM.

In any case (calibration and beam measurements), precise optics for the guiding field of the electrons (all modern IPMs used parallel E and B fields to guide electrons with a small cyclotron radius onto the MCP) as well as for the light optics are essential to achieve a good spatial resolution. Therefore simulation programs are most helpful for an optimization of both, light and electron optics [6, 7].

However, most references conclude a resolution of not better than 100 μm and a dynamic range which did not exceed 10^3 . Especially the limited dynamic range makes an IPM hardly applicably for beam halo measurements. An interesting idea was presented by [8] to overcome this situation in the J-PARC RCS; the use of an additional MCP arrangement with lower resolution but high gain for halo observations as shown in Fig. 1.

Luminescence Beam Profile Monitors (LPM)^[ii]

Nearly all monitors need an additional gas Jet of H₂ or N₂ to produce sufficient signals. The advantage of a LPM is its insensitivity to electric and magnetic fields. Therefore no space charge broadening is expected even at very bright particle beams.

There are different readout schemes in use, mainly sensitive CCD cameras [9, 10, 11] but also multi anode photo multiplier tubes (PMT) [12]. These devices have

the advantage of a very high sensitivity and therefore a reduced gas inlet (10^{-8} mbar at COSY) but the disadvantage of a limited resolution and a smaller dynamic range in respect to CCDs.

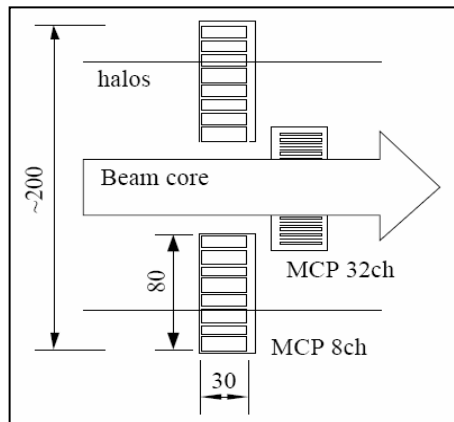

Figure 1: Schematic of the proposed MCP detector at J-PARC. The central detector of 32 channels observes the core density profile. Others of each 8 channels are prepared to investigate the beam halos [8].

Most of the reported profiles suffer from weak signals and high background signals in the beam tails. [9] has seen some broadening of the beam profile due to secondary processes like delayed decays, back-scattered protons and additional excitations due to electrons produced in inelastic collisions. More experiments to understand more accurately this behavior are in progress. [12] has added additional moveable screens next to the readout port to suppress parasitic light as well as secondary or scattered particles. However, up to now dynamic ranges of more than a few times 10^2 were not reported.

Laser Profile Monitor^[iii]

Laser based profile monitors were originally developed for electron beams, using Compton backscattering of the photons. This process depends on the square of the inverse of the mass of the particle and therefore the cross section for protons is about 10^{-6} times lower than for electrons. Nonetheless, a laser scanner can be used for photo neutralization of H⁺ beams. Both, [13] and [14], collect the emitted electrons from the neutralization to achieve a good signal to noise ratio. At SNS it is planned to replace all foreseen solid wire scanners in the superconducting LINAC by laser scanner stations because of the concern that parts of a broken wire may cause failures in the superconducting cavity. All stations will be fed by one common laser. The long optical transport distance between the Laser and the 8 stations generate an additional problems, mainly mechanical drifts and vibrations of the laser spot. This was analyzed and a piezo driven compensation feedback scheme is now foreseen to fight against the main frequencies up to 10 Hz.

At SNS a new Ti:Sapphire mode locked laser is foreseen to scan the longitudinal beam profile. The sufficient short 2 ps laser pulses are locked to the 402 MHz Linac clock and have a repetition rate of 80.5 MHz. The scan can be done by adjusting the phase of the clock signal. Both transversal beam dimensions (H⁺ and laser) should be approximately the same for a longitudinal scan, therefore the laser spot size has to be adjusted to larger dimensions than for a transversal scan where smallest spot size is mandatory.

At J-PARC [14] the energy of the liberated electrons were measured by varying the bias voltage of a repeller grid in front of the electron collector. With this method the maximum electron energy was determined from which the space charge of the beam can be calculated.

Electron Probe Profile Monitor^[iv]

Similar to a laser scanner a well focused low energy electron beam can be scanned across the hadron beam. The distortion of the electron beam path due to the electromagnetic field of the hadron beam can be observed by a screen. This method for a profile measurement was studied recently at SNS [15] with the result "... that it's feasible to use electron beam probe diagnostics for profile measurements in the SNS ring. We leave accurate estimating of the resolution to further studies, ...". The measurement of low level tails or halo was excluded. However recent studies from further references have shown promising results in theory [16, 17] and in practice [18, 19] for profile determination of the beam core (see Fig. 2).

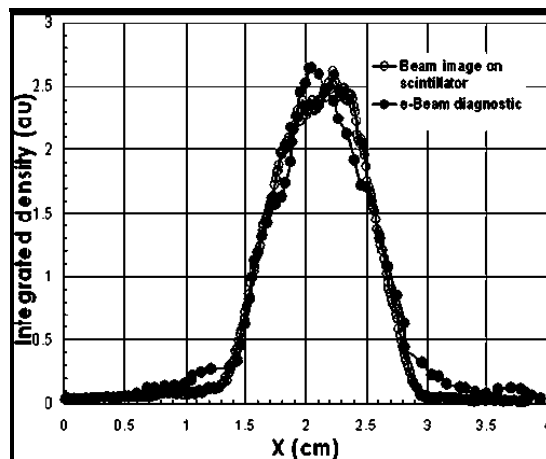

Figure 2: A comparison: Profile measurements by a scintillator screen \circ and by the e-beam probe \bullet [19].

Wire Scanners^[v]

Wire scanners are used in many laboratories for quasi non destructive profile measurements. When using a very thin (e.g. 7 μ m) Carbon wire the interaction with the beam is small enough not to threaten the beam. Nevertheless, in some cases the emittance blowup has to be taken into account [20]. Care should be taken not to melt the wire in intense and high brilliant beams [21]. In this overview I

will lay the emphasis on the extreme high dynamic range and superior sensitivity of these devices.

Different readout schemes are developed to ensure a high dynamic range: At the PSR, [22] has used a logarithmic amplifier to achieve a dynamic range of about 6 decades. At LEDA a combination of a thin wire and massive scrapers are used within one scanner [23]. The wire measures the core of the beam while the scrapers determine the beam halo. The combination of the signals gives a dynamic range of about 10^6 . In principle a counting technique offers the possibility for an even higher dynamic range. In this case the wire is moved step by step through the beam (halo) while the scattered particles are counted in scintillation counters within a given time interval. At JLAB [24] the dynamic range was improved by wires of different size to increase the signal in the beam halo. In case of intense/circulating beams, the core of the beam is scanned much faster (to protect the wire) and the profile is measured in the “normal” way by analyzing the voltage of the scintillation counter PMT [25]. The counting technique makes it possible to use a telescope of scintillators and its coincident readout [24-26] (see Fig. 3). In case of counts from beam losses close to the scanner (and dark counts of the PMT), this technique suppresses very effectively this background. A dynamic range of up to 10^8 was already achieved with the counting technique.

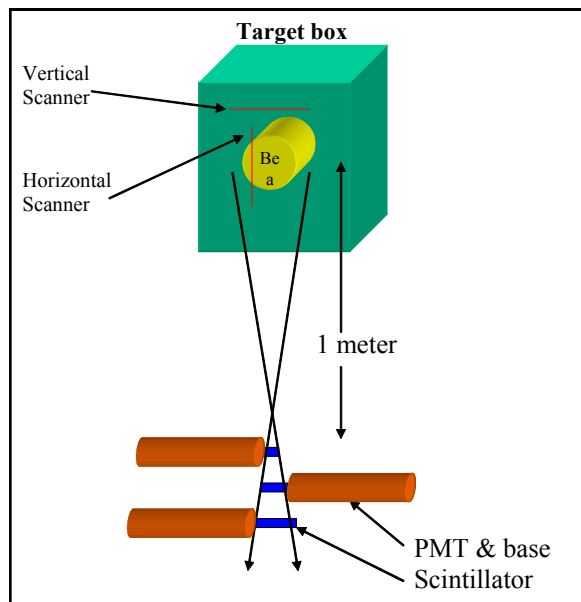

Figure 3: Illustration of a scintillators telescope used for the counting technique [26].

A completely different readout technique of a wire scanner was successfully tested by [27] by making use of the natural oscillation frequency of the stretched wire and its change with temperature while the wire is bombarded by the beam. It has been demonstrated that the vibrating wire can sense a 16 pA (!) ion beam as well as the beam halo of a circulation proton beam. A very sensitive

sensing of beam tails and a dynamic range of better than 10^7 seems applicable with such a technique.

Synchrotron Radiation^[vi]

Synchrotron radiation (SR) from protons can be used only in very high energy accelerators. Instruments are in use at Tevatron [28] and at HERA [29]. Detailed studies of the source of the radiation (Edge effect vs. Miniwigglers vs. Undulators) were done for LHC. [30] concludes that for profile measurements over the whole LHC energy range, the radiation from a superconducting undulator combined with a dipole edge will be the best solution.

An improved dynamic range ($10^6 - 10^7$) for beam halo studies might be possible by applying the idea of a coronagraph [31] to the readout system. This method makes use of the (astronomers-) idea to fade out the central spot by an opaque disk and to remove the diffraction fringe by an additional mask. Recent tests were done at SR-spots from electron beams so far.

Synchrotron radiation is considered also as a source to determine the “Beam in Gap” in LHC (see longitudinal instruments).

LONGITUDINAL INSTRUMENTS

Most high energy and high intensity accelerators need a pure abort gap for clear beam extraction. Too many beam particles inside this gap (Beam in Gap) may result in quenches, activation, equipment damage, spikes in experiments, etc. Beam in Gap may be driven by various effects like injection errors, RF problems (noise, glitches), diffusion, etc. The amount of unbunched DC beam in an accelerator can be measured by the difference of ACCT and DCCT beam current monitors, instruments which typically exist in any accelerator. However, this method averages over the whole circumference of the accelerator. Therefore a better temporal resolution is required to resolve the portion of Beam in Gap. Three different methods are presented recently:

1. Temporal beam loss distribution
2. Synchrotron Light
3. Temporal Gas Ionization distribution

Temporal beam loss distribution

The experiments at HERA (HERA-B) and Tevatron (CDF) made successful efforts to determine the Beam in Gap. In HERA-B an arrangement of thin wires was driven into the transversal beam halo to produce interactions with the wire [32]. The temporal distribution of the interaction products was measured by experiment-inherent fast counters and TDCs. At CDF the “normal” loss rate was used in conjunction with additionally installed fast counters and variable trigger delays [33]. The count rate within a certain time interval within the abort gap is proportional to the amount of Beam in Gap.

However, the beam losses used for these measurements were created in the very far transversal

halo which has an unknown relation to the core of the beam. Therefore this method has a large uncertainty in the determination of the total amount of Beam in Gap.

Synchrotron Light

The complete beam area can be observed with an appropriate optics using synchrotron light from the edge effect (limited to high energy accelerators). Since the emphasis is on the temporal distribution, a fast and gateable light detector is required. To avoid saturation of the detector a fast gating of the regular bunches is necessary. Successful tests with a gated MCP-PMT are reported by [34] whereas analogue (voltage) readout as well as very sensitive counting modes were studied. Bench tests showed a sufficient sensitivity of 50 photons / 100 ns interval. Studies of an even more sensitive readout using single-photon avalanche detectors are also ongoing [35].

Residual Gas Ionization

An extended version of an IPM was developed at GSI [36]. The electrons liberated by the collision with the residual gas are collected behind an energy analyser. These mono-energetic electrons are deflected by a RF-deflector which transforms the temporal distribution into a special distribution. Then the electrons are detected by a combination of MCP + phosphor screen + CCD camera. This method can be used in different kinds of hadron accelerators to determine the bunch length. It might also be useful to study the Beam in Gap in circular hadron accelerators, but more studies of the origin of the relative high background are still necessary.

SUMMARY

Some recent instruments and studies were reviewed in this talk with respect to their use for non-destructive beam profile and beam halo determination with the emphasis on the dynamic range of the different methods.

Transversal: The state of the art instrument with the highest dynamic range is still the wire scanner; some readout schemes reach already more than 10^7 . The wire scanner can operate sufficiently at a very wide range of beam energies. This is also true for the IPM and LPM, but unclear background issues might limit the dynamic range to not much better than 10^3 . Both devices need some in-vacuum amplification like MCPs or gas bumps which demand some special care on uniformity and control. A minimum of in-vacuum equipment is needed by the readout of synchrotron radiation, typically a mirror and a window is sufficient. Unfortunately this method is limited to very high energy proton accelerators, even with the use of wigglers or undulators. The application of the choronagraph technique might improve the dynamic range up to 10^7 , but this still has to be confirmed. The Laser Scanner technique is limited to H⁺ (and electron-) beams, but it shows (in both cases) very exciting results. A dynamic range of about 10^3 was shown and more beam diagnostics like bunch length measurement and space charge potential determination seem possible. Electron

beam probe scanning is still a more exotic technique but studies have shown its feasibility for beam profile determination. The accuracy in the beam tails seems limited; therefore there is no expectation for beam halo measurements.

Last recent note: A Schottky transversal scanning monitor has shown very impressive results at Rhic [37].

Longitudinal: The longitudinal halo is defined (at least in this report) as the bunched or unbunched beam outside the bunch-buckets and, as a result of it, the beam portion in the abort gap. The use of Synchrotron radiation in combination with fast, gated and sensitive optical detectors have shown sufficient speed and sensitivity. Gating of the main buckets provides adequate dynamic range to avoid saturation. But again, synchrotron radiation is limited to high energy accelerators. Wire scanners can overcome this limitation, but the wires have to be located in the transversal beam halo to avoid wire destruction. This might falsify the determination of the total Beam in Gap. A more general application might be provided by the use of an extended version of an IPM. This device is developed for bunch length measurements, but might also be useful for Beam in Gap detection for all hadron beams at all energies.

REFERENCES

- [i] First IPM reference: F. Hornstra: Nondestructive Beam Profile Detection Systems for the Zero Gradient Synchrotron; VI Conf. on high Energy Accel, Cambridge MA, 1967, p 374-37
- [ii] First LPM references: J.S. Fraser: Developments in Non-destructive beam Diagnostics; IEEE Trans. on Nucl. Science, Vol. NS-28, No. 3, 1981, and D.D. Chamberlin et al.: Noninterceptive Transverse Beam Diagnostic; IEEE Trans. on Nucl. Science, Vol. NS-28, No. 3, 1981
- [iii] First Laser reference: U. Schumacher (Garching, Max Planck Inst.): Electron Ring Diagnostics with Light Scattering. 1977. Muenchen Inst. Plasmaphysik - IPP 0-36
- [iv] First Probe reference: J. Shiloh, et al.: Electron beam probe for charge neutralization studies of heavy ion beams; Review of Scientific Instruments 1983, Volume 54
- [v] First Wire Scanner reference: G. Hortig; A Beam Scanner for two Dimensional Scanning with one rotating Wire: NIM 30 (1964) p. 355-356
- [vi] First Edge Effect reference: R. Coisson (Lecce U.): Narrow Band visible Synchrotron Radiation from high-energy Proton Beams; Nucl. Instrum. & Meth. 143, 1977
- [1] P. Cameron, K. Wittenburg: Halo Diagnostics Summary; Halo'03, May 19-23, 2003, Long Island, New York.
- [2] Recent news from: ICFA HB'04, BIW'04, Cyclotrons'04, PAC'04, EPAC'04, FEL'04, LINAC'04, RuPAC'04, PAC'05, DIPAC'05, FEL'05, BIW06, Journals 03 – 06.

- [3] A. Jansson et al.: An Ionization Profile Monitor for the Tevatron; PAC'05, 16-20 May 2005 and A. Jansson et al, Tevatron Ionization Profile Monitors; BIW06, Fermilab, Il
- [4] R. Connolly, et al.: Residual-gas-ionization beam profile monitors in RHIC; PAC'05, 16-20 May 2005, Knoxville, Tennessee
- [5] D. Liakin, et al.: Improving the Reliability of IPM; DIPAC05, 6 -8 June 2005, Lyon, France
- [6] B. Dehning, et al.: Simulation of an electron source based calibrating system for an ionisation profile monitor; DIPAC'05, 6 -8 June 2005, Lyon, France.
- [7] B. Dehning, et al.: Optical design for BIPM imaging system; DIPAC'05, 6 -8 June 2005, Lyon, France.
- [8] S.Lee et al.: Design Studies of a nondestructive Beam Profile and Halos Monitor based on residual Gas Ionization for the J-Parc RCS; 14th Symp. on Accel. Sci. and Techn. Tsukuba, Japan, Nov. 2003
- [9] P. Ausset, et al.: Optical Transverse Beam Profile Measurements for High Power Proton Beams; EPAC'02, 3 - 7 June 2002, La Villette, Paris
- [10] N.P. Luciano, et al.: Luminescence beam profile monitor for the RHIC polarized hydrogen jet polarimeter; PAC2005, 16-20 May 2005, Knoxville, USA
- [11] S. H. Han, Y. S. Cho; Beam Profile Measurement with CCD Camera at PEPF; APAC'04, 22 - 26 March 2004, Gyeongju, Korea
- [12] N.I. Balalykin, et al.: Development of beam position and profile monitor based on light radiation of atoms excited by the beam particles; RuPAC'04, Dubna, Russia, 4 - 9 Oct 2004.
- [13] W. Bockland et al.: SNS Laser Profile Monitor Progress; EPAC'04, 5 - 9 July 2004, Lucerne, Switzerland
- [14] Seishu Lee et al.: Direct Measurements of Space-Charge-Potential in High Intensity H- Beam with Laser Based Photo Neutralization Method; DIPAC'05, 6 -8 June 2005, Lyon, France
- [15] A.V. Aleksandrov et al.: Feasibility study of using an Electron Beam for Profile Measurements in the SNS Accumulator Ring; PAC'05, 16-20 May 2005, Knoxville, Tennessee
- [16] D. A. Gutorov et al.: The Beam Probe Diagnostic Simulation; RuPAC'04, Dubna, Russia, 4-9 Oct 2004
- [17] D. Liakin: The Analysis of the Electron Beam Scanning Method for the Beam Profile Monitoring.; EPAC'04, 5 - 9 July 2004, Lucerne, Switzerland
- [18] P.V. Logachov et al.: Electron beam probe as a nondestructive single bunch diagnostic tool for circular colliders; RuPAC'04, Dubna, Russia, 4 - 9 Oct. 2004,
- [19] K. Roy et al.: Electron-beam diagnostic for space-charge measurement of an ion beam; Rev. Sci. Instrum. 76, (2005)
- [20] F. Roncaolo, B. Dehning: Transverse Emittance Blow-up due to the Operation of Wire Scanners, Analytical Predictions and Measurements; PAC'05, 16-20 May 2005, Knoxville, Tennessee
- [21] L. Fröhlich: Thermal Load on Wire scanners; Workshop on Future Light Sources; May 15-19, 2006, Hamburg, Germany
- [22] A. Browman et al.: Halo Measurements of the Extracted Beam at the Los Alamos Proton Storage Ring; PAC'03, May 12-16, 2003, Portland, Oregon.
- [23] J. D. Gilpatrick: Wide Dynamic-Range Beam-Profile Instrumentation for a Beam-Halo Measurement: Description and Operation; Halo'03, May 19-23, 2003, Long Island, New York.
- [24] A. Freyberger: Large Dynamic Range Beam Profile Measurements; DIPAC'05, 6 -8 June 2005, Lyon, France.
- [25] S. Arutunian et al.: Beam Tail Measurements using Wire Scanners at DESY; Halo'03, May 19-23, 2003, at Long Island, New York.
- [26] D. Gassner et al.: Scintillator Telescope in the AGS Extracted Beamline; 29th ICFA Advanced Beam Dynamics Workshop on Beam Halo Dynamics, Diagnostics, and Collimation, May 19-23, 2003, Long Island, New York.
- [27] S.G.Arutunian et al.: PETRA Proton Beam Profiling by vibrating Wire Scanner; DIPAC'05, Lyon, France, 6-8Jun 2005.
- [28] H. W. K. Cheung et al.: Performance of a Beam Monitor in the Fermilab Tevatron using Synchrotron Light; PAC'03, May 12-16, 2003, Portland, Oregon and R. M. Thurman-Keup: Proton Synchrotron Radiation at Fermilab, BIW'06, May 1-4, 2006, Fermilab, Batavia, Illinois
- [29] G. Kube et al.: Proton Synchrotron Radiation Diagnostics at HERA; BIW'06, May 1-4, 2006, Fermilab, Batavia, Illinois
- [30] L. Ponce et al.: LHC Proton Beam Diagnostic using Synchrotron Radiation; CERN-2004-007
- [31] T. Mitsuhashi: Beam Halo observation by Choronagraph; DIPAC 2005, Lyon, France, 6-8 Jun 2005.
- [32] K. Ehret et al.: Observation of coasting beam at the HERA proton ring; Nucl.Instrum.Meth.A456:206-216, 2001
- [33] Muge Karagoz Unel: Beam halo monitoring at CDF; Nucl.Instrum.Meth.A506:7-19, 2003
- [34] J.-F. Beche et al. : Design of an Abort Gap Monitor for the Large Hadron Collider; January 7, 2005 LARP Note 1 and J.M Byrd; Gated Microchannel Plate Photomultipliers For Longitudinal Beam Diagnostics; BIW'06, May 1-4, 2006, Fermilab, Batavia, Illinois
- [35] S. Hutchins et al.: Single photon detector tests for the LHC synchrotron light diagnostics; DIPAC'05, Lyon, France, 6-8 Jun 2005.
- [36] P. Forck, C. Dorn: Measurements with a Novel Non-Intercepting Bunch Shape Monitor at the High Current GSI-LINAC; DIPAC'05, Lyon, France, 6-8 Jun 2005.
- [37] P. Cameron: private communication