

# Nondestructive DC Beam Current Monitor with Nano-Ampere Resolution

Yuuichirou SASAKI, Kichiji HATANAKA, Kenji SATO, Tetsumi TANABE\*,  
Shinpei ONO\*, Kouji NODA\*\*, Kei SHINADA\*\*\*, Yasuharu YAMADA\*\*\* and Kouichi NAKANO\*\*\*

Research Center for Nuclear Physics, Osaka Univ.,  
Osaka 567-0047 JAPAN

\*Center for Nuclear Study, School of Science, Univ. of Tokyo,  
Tokyo 188-0002 JAPAN

\*\*National Institute of Radiological Sciences,  
Chiba 263-8555 JAPAN

\*\*\*Technology Research Laboratory, Shimadzu Corporation,  
Kyoto 619-0237 JAPAN

## Abstract

A beam intensity monitor using a DC-SQUID is being designed in order to measure the ion beam intensity in a non-destructive manner. Prior to the design procedure, some fundamental tests were performed with models. A small size transformer was installed between the pick up coil and the input coil of the SQUID in order to take matching. Measurements were performed to optimize SQUID-outputs, shielding effects, and noise levels of the system. Results are described in this report.

## 1 INTRODUCTION

There are various systems developed to measure beam intensities from accelerators. Scintillators cover the region up to  $10^6$  particles per second (pps), corresponding to electrical currents up to 1 pA. Current transformers of the flux-gate type can cover the region over some  $\mu\text{A}$  in a non-destructive manner. The region in between can be covered by ionization chambers (IC) and secondary emission monitors (SEM). But these systems more or less distort the ion beam due to the energy loss and the beam emittance growth by scatterings. Another type of beam transformer, using the principle of a Cryogenic Current Comparator<sup>1</sup> (CCC), is being designed at the Research Center for Nuclear Physics (RCNP), Osaka University in collaboration with the National Institute of Radiological Sciences (NIRS). In the design, a DC-SQUID is adopted to improve the resolution. The nA resolution is expected.

## 2 A SQUID SYSTEM

Figure 1 shows the circuit diagram of a SQUID and a flux locking loop. SQUID, a matching transformer, the pick up, the input and the feedback coils are coupled.

$$\begin{cases} (L_p + L_{t,1})\Delta I_p + M_t\Delta I_t = N_p \cdot \Delta\phi_b \\ (L_{t,2} + L_{i,1} + L_{i,2} + \Lambda_1 + \Lambda_2)\Delta I_t \\ + (M_{fi,1} + M_{fi,2})\Delta I_f + M_t\Delta I_p = 0 \\ M_{is,1}\Delta I_t - M_{fs,1}\Delta I_f = 0 \\ M_{is,2}\Delta I_t - M_{fs,2}\Delta I_f = 0, \end{cases} \quad (1)$$

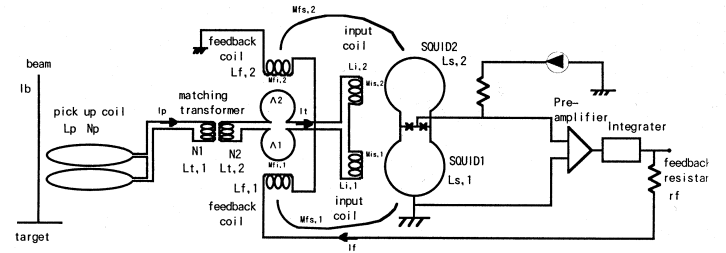

Figure 1: Circuit diagram of a SQUID and flux locked loop.

where  $L_p$  is the pick up coil inductance,  $L_{i,1}$  and  $L_{i,2}$  the input coil inductances,  $L_{t,1}$  and  $L_{t,2}$  inductances of the matching transformer.  $M_{fi,1}$  and  $M_{fi,2}$  are the mutual inductances between the input coil and the feedback coil,  $M_{is,1}$  and  $M_{is,2}$  those between the input coil and SQUID.  $M_t$  is the mutual inductance between the input coil of the matching transformer and the output coil of the matching transformer.  $I_p$ ,  $I_t$  and  $I_f$  is the current through the pick up coil, through the input coil and through the feedback coil, respectively.  $\Phi_b$  is the flux which penetrates the pick up coil.  $\Lambda_1$  and  $\Lambda_2$  are the inductances of the coils between the matching transformer and the input coil.  $N_p$  is the number of the pick up coil windings.  $\Phi_x$  is the flux which penetrates the SQUID. The current  $I_f$  is fixed under the condition  $I_b = 0$ , and then the flux  $\Phi_x$  is locked. When  $I_b$  is fed, the feedback current  $I_f$  changes to keep the flux  $\Phi_x$  constant. The amount of change in  $I_f$  is proportional to the current  $I_b$ . Parameters of the SQUID sensor used are given in Table 1.

Using relations  $L_{i,1} + L_{i,2} = L_i$ ,  $\Lambda_1 + \Lambda_2 = \Lambda$ ,  $M_{fi,1} + M_{fi,2} = M_{fi}$ ,  $M_{is,1} = M_{is,2} = M_{is}$ ,  $M_{fs,1} = M_{fs,2} = M_{fs}$ ,  $\Delta\phi_b = l_p \Delta I_b$ , we can solve equation (1) to get

$$\Delta I_f = \frac{\frac{M_{is}}{M_{fs}}}{L_i + \Lambda + \frac{M_{fi} M_{is}}{M_{fs}} + \frac{L_p L_{t,2}}{L_p + L_{t,1}}} \cdot \frac{M_t}{L_p + L_{t,1}} l_p N_p \Delta I_b, \quad (2)$$

where  $l_p = \frac{\mu^* \mu_0 h c}{2\pi} \ln\left(\frac{r_o}{r_i}\right)$ ,  $\mu^*$  is the magnetic permeability

Table 1: Parameters of the SQUID.

$\Lambda_1$	125pH	$M_{is,1}$	5nH	$M_{fi,1}$	3nH
$\Lambda_2$	125pH	$M_{is,2}$	5nH	$M_{fi,2}$	3nH
$L_{i,1}$	100nH	$L_{s,1}$	250pH	$L_{f,1}$	75nH
$L_{i,2}$	100nH	$L_{s,2}$	250pH	$L_{f,2}$	75nH

of the VITROVAC core,  $h_c$  the height of the pick up coil's core,  $2r_o$  the outer diameter,  $2r_i$  the inner diameter.  $N_1$  and  $N_2$  is the number of the matching transformer windings for the input and the output coil, respectively.  $L_p$ ,  $L_{t,1}$ ,  $L_{t,2}$  and  $M_t$  are expressed by  $N_p$ ,  $N_1$  and  $N_2$  as followings.

$$L_p = l_p N_p^2, \quad L_{t,1} = l_0 N_1^2, \quad L_{t,2} = l_0 N_2^2 \quad (3)$$

Conditions to maximize the response  $\frac{\Delta I_t}{\Delta I_b}$  are obtained from the equation (2)

$$L_p \left( \frac{N_2}{N_1} \right)^2 = \frac{M_{fi} M_{is}}{M_{fs}} + L_i + \Lambda \quad (4)$$

and

$$\frac{l_p N_p^2}{l_0 N_1^2} \ll 1. \quad (5)$$

### 3 TEST WITH SMALL SIZE MODELS

Models were fabricated to examine the performance of the system. Figure 2 shows one of them. The system consists of a superconducting magnetic shielding, a pick up coil, and a SQUID. The beam current is simulated with a one turn loop around the magnetic shielding. The loop current induces an azimuthal magnetic field. Because of the shielding structure, the azimuthal component of the magnetic field can penetrate into the shielding with small attenuation, while other components are strongly attenuated. In order to realize high sensitivity, it is necessary to reduce noises around the pick up coil and the SQUID. Measurements were performed to investigate sensitivities, noise structures, and shielding effects of the system using a VITROVAC 6025-F toroidal core surrounded by 4 turns pick-up of NbTi wire. The feedback resistance was 4.7 k $\Omega$ .

#### 3.1 Sensitivity

Sensitivity was initially studied without a matching transformer. The measured sensitivity was 25-28 mV/10 nA. In the next step, sensitivities were studied for three kinds of matching transformers with a winding ratio of 4:1, 14:3 and 72:14. They satisfy the equation (4). When the transformer with a winding ratios of 4:1 or 14:3 was used,  $\frac{l_p N_p^2}{l_0 N_1^2}$  was 3 or 0.25. The equation (5) was not satisfied. On the other hand, when the transformer with a winding ratio of

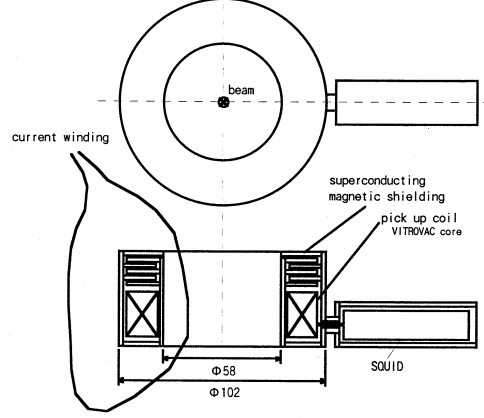

Figure 2: Schematic drawings of the model. The magnetic shielding is a folder type with five ring type shield elements.

72:14 was used,  $\frac{l_p N_p^2}{l_0 N_1^2}$  was 0.01 and the condition (5) was fulfilled. The sensitivities measured and calculated from equation (2) are given in Table 2. When the transformer with a winding ratio of 4:1 was used, the measured sensitivity was as low as that without a matching transformer. When the transformer with a winding ratio of 72:14 was used, the measured sensitivity was 50-54 mV/10 nA. This is about twice as high as that without a matching transformer.

Table 2: Sensitivities obtained with models. Responses were measured with 10 nA, dc current.

$N_1 : N_2$	SQUID-output	
	measured	calculated
without a transformer	25-28 mV	25 mV
4:1	23-24 mV	25 mV
14:3	42-50 mV	53 mV
72:14	50-54 mV	59 mV

#### 3.2 Noise

The noise levels were investigated. When a matching transformer was not used, the obtained noise level was a little larger than 15 mVpp. When the 4:1 matching transformer was used, the noise level was 22 mVpp. These noise levels correspond to 7 and 9.4 nA, respectively. When the 72:14 matching transformer was used, the noise level was 25 mVpp. This noise level corresponds to 4.8 nA.

The noise spectrum with the 72:14 matching transformer is shown in Figure 3. The frequency of main electromagnetic noise is 60 Hz. In the region up to 10 Hz, the 1/f noise dominates. The thermal noise is noticeable in the frequency range higher than 10 Hz. In order to reduce the noise level, a low pass filter with the cut-off frequency of

10 Hz was installed in the system. When the low pass filter was applied, the noise level was reduced to 10 mVpp with the 72:14 matching transformer. This noise level corresponds to 2 nA. The noise spectrum in this measurement is shown in Figure 4. The thermal noise and the 60 Hz electromagnetic noise were remarkably reduced. The main noise remained was the 1/f noise. Figure 5 shows outputs for a 10 nA test pulse.

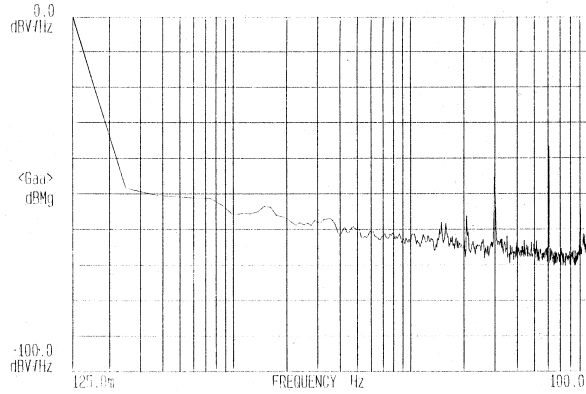

Figure 3: The noise spectrum measured with the 72:14 matching transformer. The low pass filter was not installed.

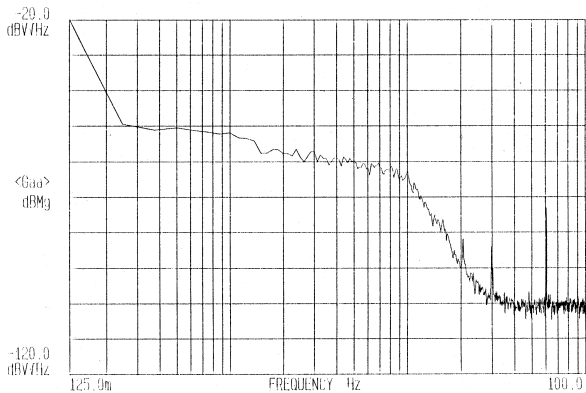

Figure 4: The noise spectrum measured with the 72:14 matching transformer and the low pass filter.

### 3.3 Shielding Efficiency

Further measurements were carried out to study the influence of external magnetic fields. A field of  $10^{-5}$  T yields the following apparent currents:

$$\begin{aligned} \vec{B} \parallel \vec{I} & 9nA \\ \vec{B} \perp \vec{I} & 30nA \end{aligned}$$

These values are larger by an order of magnitude than that required for the environment in which this system will be installed for actual usage.

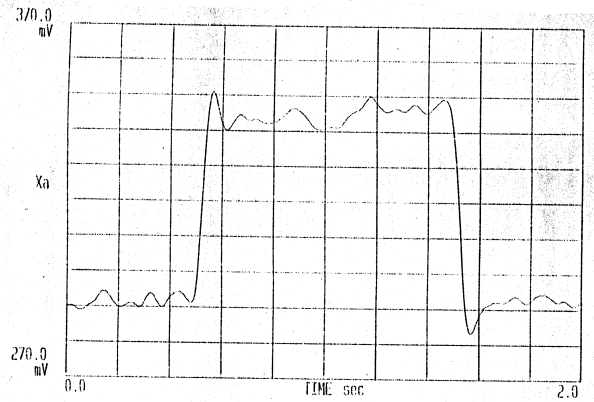

Figure 5: 10 nA pulse, 1 sec pulse width with the low pass filter. The 72:14 matching transformer is used. (horizontal axis: 0.2 sec/div., vertical axis: 10 mV/div.)

## 4 CONCLUSION

The SQUID-output voltage can be calculated from equation (2). The conditions that sensitivity is maximum are equation (4) and (5). These conditions were satisfied by means of the matching transformer with a winding ratio of 72:14 for the present model. The noise level was reduced to 2 nA in the measurement with the 72:14 matching transformer and the 10 Hz low pass filter. The main noise remained was the 1/f noise.

This work is supported in part by the Grants-in-Aid for Scientific Research No. 09640357 of Ministry of Education, Science and Culture.

## 5 REFERENCES

- [1] A. Peters et al., "A Cryogenic Current Comparator for Non-destructive Beam Intensity Measurements", Proc. 1994 the Fourth European Part. Accel. Conf., London, (1994) 290.
- [2] A. Peters, H. Reeg, C.H. Schroeder, W. Vodel, H. Koch, R. Neubert, "Absolute Measurements and Analysis of nA-Ion Beams" Proceedings of the Third European Workshop on Beam Diagnostics and Instrumentation for Particle Accelerators (DIPAC '97), Frascati, Italy, Oct. 1997
- [3] Y. Sasaki, K. Hatanaka, K. Sato, T. Tanabe, S. Ono, K. Noda, K. Shinada, Y. Yamada, K. Nakano, "Nondestructive DC Beam Current Monitor with NANO-Ampere Resolution", Proceedings of the 11th Symposium on Accelerator Science and Technology, Harima Science Garden City, Hyogo, Japan, p. 255, October 1997
- [4] K. Shinada et al., Shimadzu Review 51 (1994) 217.