

ELECTROMAGNETIC SIMULATIONS OF COAXIAL TYPE HOM COUPLER*

G. Wu[#], H. Wang, R. Rimmer, C. Reece, Jefferson Lab, Newport News, VA 23606, U.S.A.

Abstract

The DESY-type coaxial high order mode (HOM) coupler has been used in many superconducting cavities. The electric probe tip is located at the maximum B-field inside the coupler can. For continuous wave (CW) high current applications, the heating of this tip can be severe enough to degrade the cavity performance. Electromagnetic (EM) simulations were done to estimate tip heating under a variety of conditions. Geometric remedies and detuning sensitivity effects were examined. The effect of these changes on HOM external quality factor (Q_{ext}) was also estimated. HOM probe tip heating power was calculated for the upgraded JLAB Low-Loss (LL) cavity shape and 750 MHz injector cavities.

INTRODUCTION

The probe tip of DESY type HOM coupler is located right in the electric field minimum for the cavity fundamental mode to reduce the power transmission through the HOM coupler. The electric field minimum is also a magnetic field maximum in this transmission line type HOM coupler. The current on the coupler tip surface causes the heating problem. To maximize the HOM damping of CEBAF Upgrade cavities both on Low Loss and High Gradient shapes, the HOM coupler position was moved closer to the end cell. This increased the magnetic field ratio between the coupler tip and the cavity equator and produced extra heat on the coupler tip. If the heat is not sufficiently conducted away through the probe feedthrough, it can lower the cavity quality factor (Q) or even cause the tip to become normal conducting. This note describes simulation results of the local magnetic field around the tip calculated by HFSSTM code.

NUMERICAL MODELING

Geometry and meshing

A 3D model (Figure 1) was initially built in mechanical engineering software. The fillet geometries at the notch gap and the two inductive stubs inside the HOM coupler were eliminated to avoid dense meshes on those corners in the 3D meshing. The model was later transferred to HFSSTM. Meshing was manually seeded in three different volumes: cavity, HOM coupler and notch gap.

The RF filter behavior is very sensitive to notch gap distance, thus the mesh in that region was refined until the variation of filter frequency response was negligible. Another reason for a manual mesh is that HFSSTM uses an adaptive meshing refinement based on energy flow;

adaptive meshing would not achieve the desired fine mesh for the HOM coupler since the energy flow would be very small and the solving frequency is always away from the desired notch frequency.

Electromagnetic model

To save computational time, only one end cell is used in the model instead of the whole JLAB low loss 7-cell cavity. Since end cells usually have a different frequency than center cells, the HOM notch gap was changed to the corresponding cavity frequency. We believe this change will not affect overall electromagnetic behavior. A coaxial line was inserted in the left side beam pipe to act as an input probe to transmit RF power. The output is a 50 Ω coaxial line connected to the HOM probe tip.

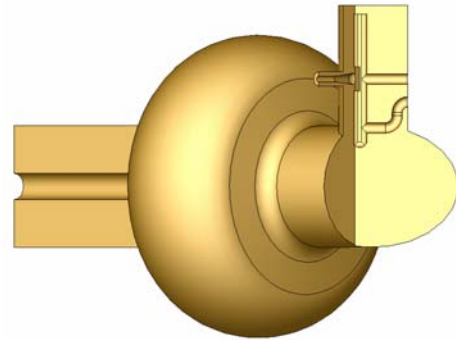

Figure 1: 3D RF model used in the HFSSTM simulation. The HOM coupler and the right side beam pipe was cut away by 135-degree to show the inside geometry.

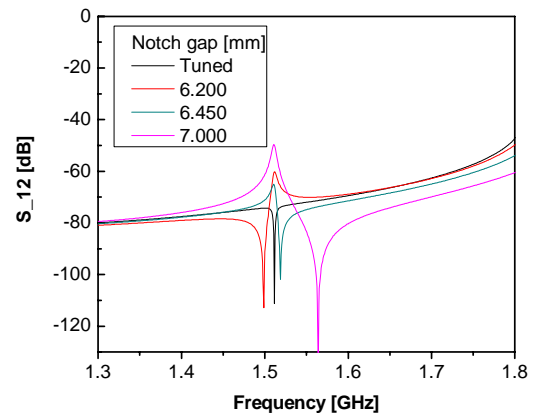

Figure 2: The frequency tuning of the notch filter.

To calculate the local magnetic field around the tip, or the heating power, the notch frequency has to be tuned to the cavity resonance. The notch gap distance was varied to mimic the real world notch frequency tuning. A

*This manuscript has been authorized by SURA, Inc. under Contract No. DE-AC05-84ER-40150 with the U.S. Department of Energy.

[#]genfa@jlab.org

frequency sweep (Figure 2) showed the notch frequency was tuned to suppress the RF transmission for cavity fundamental mode. Then probe tip heating was obtained. The probe tip field and the magnetic heating were normalized to the cavity equator field.

TIP HOM COUPLING

Studying the HOM coupler frequency response to other than the fundamental mode can help to estimate the HOM damping as it is affected by tip geometry and coupling gap distance. Figure 3 shows the first monopole mode with different tip geometries and coupling gap for LL cavities. The computed Q_{ext} for the monopole is listed in Table 1.

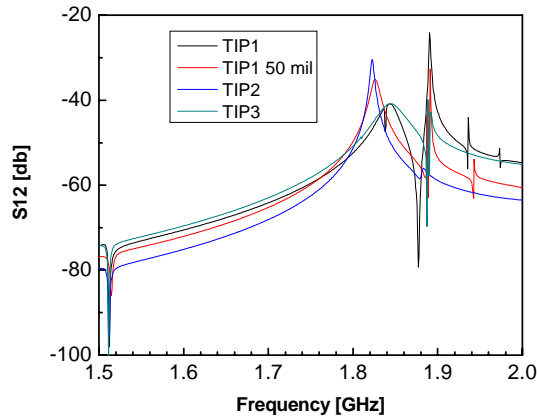

Figure 3: Transmission coefficient for three tips.

As shown in Table 1, the HOM damping decreases when the coupling gap of probe tip is increased. TIP2 has smaller surface heating, as shown later, and the reduced tip size reduced the HOM damping effect by a factor of 5. Other modes will show different behavior under the same circumstances, which will be the subject of a separate paper.

PROBE HEATING

To prevent tip thermal runaway, one can increase the thermal conductivity of the coaxial feedthrough [1] or reduce surface heating. Three different tip geometries were investigated. The HOM notch filter frequency was also tuned to see if tuning could relocate the maximum surface magnetic field and reduce the tip heating.

Tip geometric effect

Three tip geometries are TIP1: the standard tip, TIP2: the straight rod shaped tip which has reduced surface area and TIP3: nail shaped tip which has reduced surface area but maintains tip coupling surface area. Tip geometries and surface magnetic field are illustrated in Figure 4.

Peak surface magnetic fields are listed in Table 1 normalized to the end cell equator magnetic field. Assuming the tip surface resistance of $12 \mu\Omega$ (Nb at 8 K),

we calculated the total surface heating power for unit accelerating gradient for three tips.

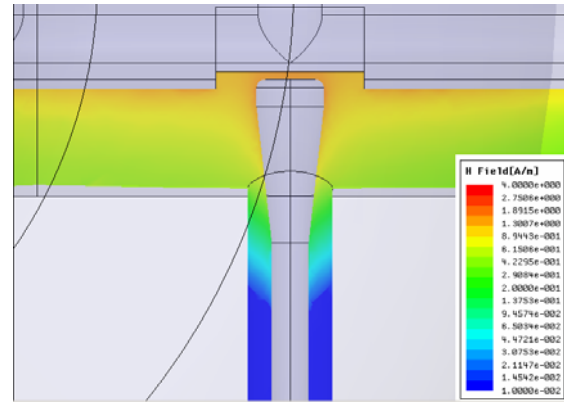

(a)

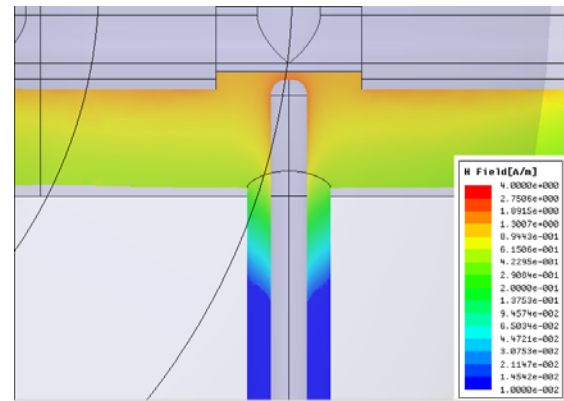

(b)

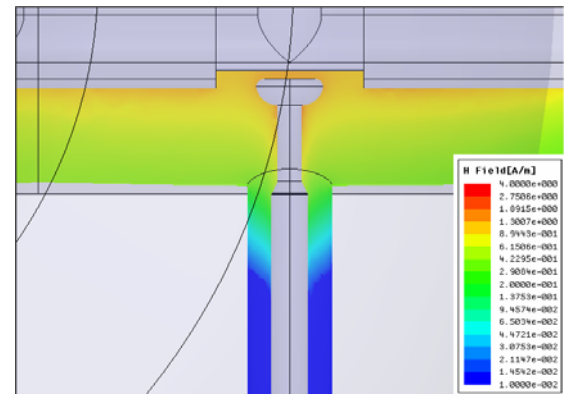

(c)

Figure 4: The local magnetic field around probe TIP1 (a), TIP2 (b) and TIP3 (c).

Table 1 shows that TIP2 surface magnetic field was enhanced due to reduced surface radius. The smaller surface area contributed to its lowest surface heating comparing to the other two tips. TIP3's reduced surface heating did not reduce tip temperature due to its reduced thermal conductance from tip head to the coax feedthrough [2].

Table 1: Surface magnetic field, heating and HOM Q_{ext}

Geometry	Surface H field	Surface heating (W)	HOM Q_{ext}
TIP1*	9.25%	4.34×10^{-5}	7.9×10^4
TIP1	10.83%	5.72×10^{-5}	3.9×10^4
TIP2	12.25%	3.09×10^{-5}	1.9×10^5
TIP3	9.33%	3.87×10^{-5}	2.5×10^4

*Tip coupling gap was 50-mil, while others had 30-mil.

The tip coupling gap was increased for TIP1* from nominal 30-mil to 50-mil. Surface heating was reduced by 24%. Overall, none of the configurations offered much big improvement.

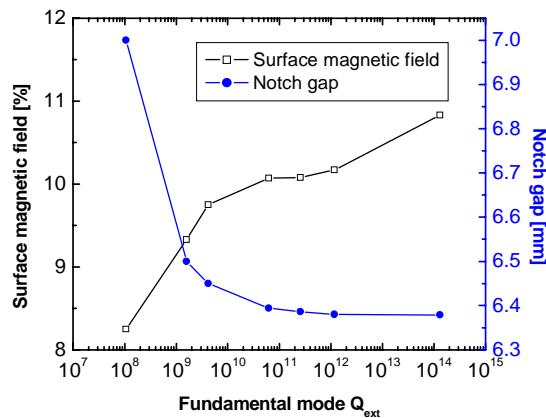

Figure 5: Q_{ext} for TM_{010} mode and tip surface field for different notch gap of TIP1.

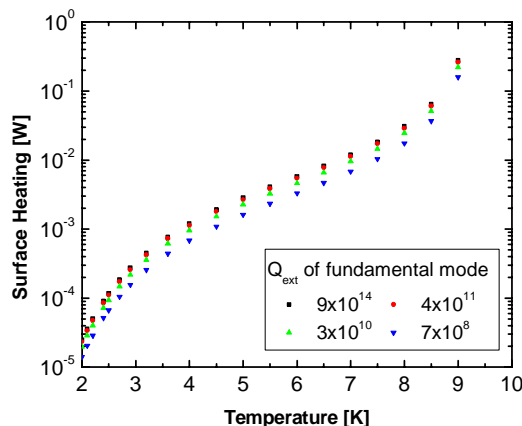

Figure 6: Surface heating vs. tip temperature for LL cavity niobium probe TIP1 at 20 MV/m E_{acc} .

Tuning effect

When the HOM notch frequency was detuned, the HOM external Q for fundamental mode decreased, indicating the tip electrical field increased and magnetic field decreased. Figure 5 shows the tip surface field

decreased merely from 10.8% to 10.1% when fundamental mode Q_{ext} decreased to 6×10^{10} . Obviously this is not attractive since the Q_{ext} below 10^{12} would cause too much fundamental power transmission through HOM coupler.

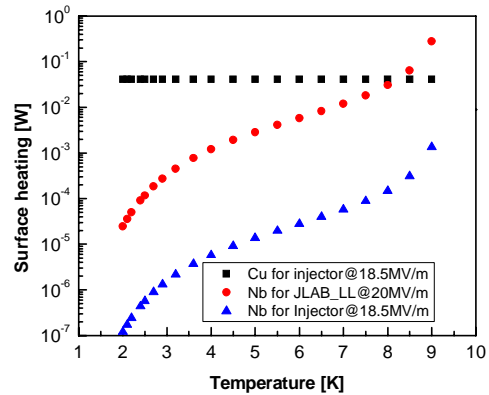

Figure 7: Surface heating vs. tip temperature for Nb or Cu probe tip of 750 MHz injector cavities compared to LL cavities.

LL cavities and 750 MHz injector cavities

HOM probe tip heating were estimated for both LL cavities and 750 MHz injector cavities. For LL cavities, the probe tip is made of high quality niobium. Niobium surface resistance increases significantly when its temperature gets closer to transition temperature. The RF heating around niobium tip in a LL cavity operating at 20 MV/m is plotted for various tip temperatures (Figure 6). The later thermal simulation [2] incorporated these data and confirmed there would be a thermal quench for niobium tip which eventually caused cavity Q degradation as experienced in cold tests [3].

The 750 MHz injector cavities are single cell cavity designed for JLAB's high current injector. It adopted the SNS HOM coupler design except the loop orientation and will be operated at higher accelerating gradient and in CW mode compared to lower accelerating gradient pulsed mode for SNS. The copper probe surface heating will be stable since copper surface resistance remains constant up to 40 K. If niobium probe is adopted, its surface heating will be relatively low compared to the thermal-quenched niobium probe in the LL cavities. The 750 MHz injector cavity probe heating under various tip temperature is shown in Figure 7. Both copper and niobium probe heating were estimated at nominal accelerating gradient of 18.5 MV/m.

CONCLUSION

The simulations of magnetic field strength at the tips show that the notch detuning has only a weak effect. TIP2 and TIP1 with increased coupling gap sacrifice HOM damping, but decrease of the surface magnetic field was not significant. TIP3 maintains the same HOM damping

and, with the same tip head size, did not show an elevated tip magnetic field, but decreased thermal conductance canceled the benefit of reduced total surface heating. Because the niobium tip surface heating increases exponentially when tip temperature increases, the thermal properties of the probe and feedthrough are most important. Overall, the simulation proved to be a valuable tool for further RF/thermal analysis with complex structures. The combination of using a high thermal conductivity coaxial feedthrough [1] and alternative material or coupler structure [3] may be the solution for this type of HOM coupler for high gradient, CW applications.

REFERENCES

- [1] C. E. Reece, E. F. Daly, T. Elliott, H. L. Phillips, J. P. Ozelis, T. Rothgeb, K. Wilson, and G. Wu, "High thermal conductivity cryogenic rf feedthroughs for higher order mode couplers", PAC'05, Oak Ridge, May 2005, <http://www.jacow.org>.
- [2] K. Wilson, JLAB technote, JLAB-TN-04-022.
- [3] P. Kneisel, J. Sekutowicz, G. Ciovati, G.R. Myneni and G. Wu, "Testing of hom coupler designs on a single cell niobium cavity", PAC'05, Oak Ridge, May 2005, <http://www.jacow.org>.