

A COUPLED RFQ-IH CAVITY FOR THE NEUTRON SOURCE FRANZ*

M. Heilmann, D. Mäder, O. Meusel, U. Ratzinger[†], A. Schempp, M. Schwarz
IAP, Frankfurt University, 60438 Frankfurt am Main, Germany

Abstract

The Frankfurt neutron source FRANZ [1] will deliver neutrons in the energy range up to 500 keV with high pulsed intensities. A 2 MeV proton beam will produce protons via the ${}^7\text{Li}(p, n){}^7\text{Be}$ reaction. The 175 MHz accelerator cavity (Table 1) consists of a 4-rod-RFQ [2] coupled with an 8 gap interdigital H-type drift tube [3] section, the total cavity length being 2.3 m. The combined cavity will be powered by one RF amplifier to reduce investments and operation costs. The inductive power coupler will be at the RFQ part. The coupling into the IH-section is provided through a large aperture - mainly inductively. By CST-MWS-simulations [4] as well as by an RF model (Fig. 1) the voltage tuning along the cavity was investigated, and with special care the balance between both cavity sections. A first set of RFQ electrodes should allow to reach beam currents up to 50 mA in cw operation. The beam is pulsed with 100 ns, 250 kHz, while the cavity has to be operated cw due to the high repetition rate. The layout of the cavity cooling is adequate for a maximum heat load of 200 kW.



Figure 1: Coupled 1:2 RFD-DTL model for investigation of the coupling between two different accelerator structures. The RF-dipole (RFD)-model shows a capacity load per meter which is equivalent to the RFQ structure.

INTRODUCTION

The coupling of RF components is beneficial in many cases to reduce the RF amplifier costs and to profit from short drifts between accelerator sections - usually an advantage in high current beam dynamics. A IH-RFQ IH-DTL combination was suggested in ref. [5]. Such a combination was realized for the first time recently [6]. One difficulty in this case is the large diameter difference between RFQ and IH-section, due to the high capacitive load of an RFQ. The coupled structure for FRANZ consists of a 4-rod-RFQ and an IH-DTL. The resonance frequency is the same in both structures and can be driven in 0 and π -mode. It's possible to switch between these two modes after adapting the drift between both sections. The FRANZ-combination is investigated for the 0-mode [7, 8, 9]. The coupling between RFD and IH-DTL is mainly inductive.

Table 1: Parameters of FRANZ-RFQ-IH combination at 140 mA beam current. Parameters in brackets are valid for the 50 mA electrode design.

Parameter	Unit	
Particle		Proton
Frequency	MHz	175
Current	mA	(50) 140
RFQ Input-Energy	keV	120
IH-DTL Input-Energy	keV	700
IH-DTL Output-Energy	MeV	2.03
RFQ Thermal Losses	kW	139
IH Thermal Losses	kW	75
RFQ $\epsilon_{in}^{trans.,norm.,rms}$	mm mrad	0.4
IH $\epsilon_{X,out}^{trans.,norm.,rms}$	mm mrad	0.9
IH $\epsilon_{Y,out}^{trans.,norm.,rms}$	mm mrad	1.09
IH $\epsilon_{Z,out}^{trans.,norm.,rms}$	keV ns	5.2
RFQ - # of Cells		(97) 95
IH - # of Cells		8
RFQ - # of Stems		18
IH - # of Stems		6
RFQ - Aperture	mm	4
IH - Aperture	mm	22-24
RFQ - Dimension	mm	300x340x1825
IH - Dimension	mm	412x642x560
Electrode voltage	kV	(61) 75
Coupling constant		0.03
Q - Factor		8000
Shunt impedance	M Ω /m	69

* Work supported by HIC for FAIR and DFG

[†] u.ratzinger@iap.uni-frankfurt.de

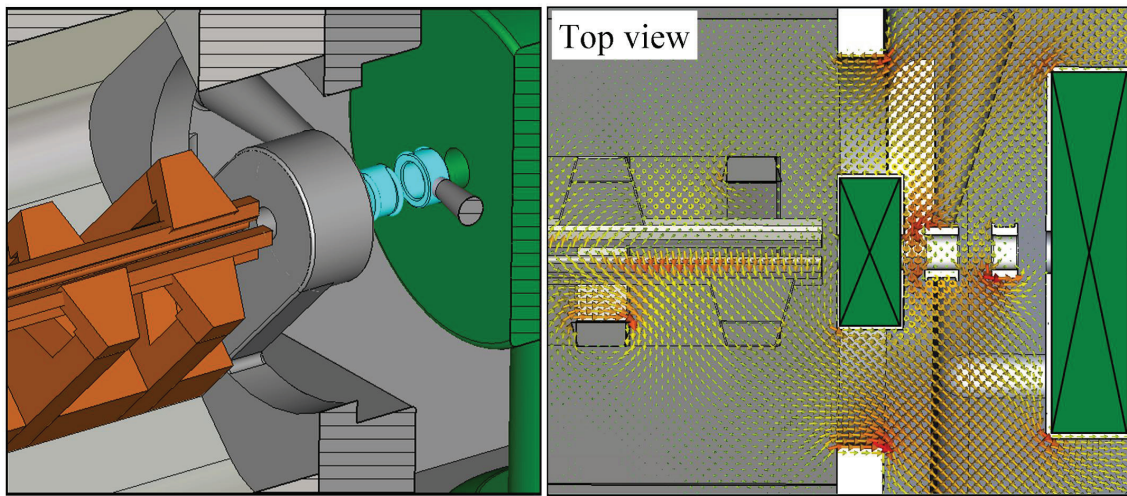

Figure 2: Side and top view of the coupling area. The RFQ is on the left side and the IH-DTL on the right. The arrows represent the magnetic field in the coupling area. The inductive coupling occurs through a large aperture from the RFQ to the IH-section.

COUPLED RFD-IH COMBINATION

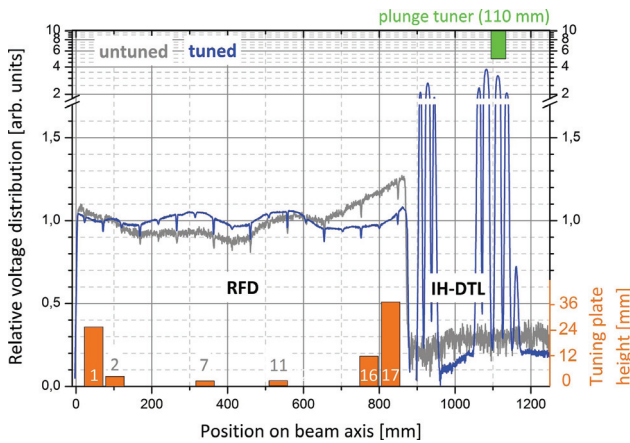

Figure 3: The relative voltage distribution along the coupled 1:2 RFD-DTL model (blue for optimized tuner positions). In green the IH-plunger position and in orange the heights of tuning plates in the RFD are shown. The voltage profile directly after coupling the untuned cavities is shown in grey.

The results from simulations by CST-MWS and from measurements can be summarized as follows:

- While the IH simulation results are well reflected by measurements, the voltage distribution along the RFD as well as the absolute resonance frequency of the ground mode are showing significant error bars. The coupled cavity simulation (Fig. 2) results can be used only as a first orientation. Therefore the construction of a 1:2 scaled rf model was well justified in this case.
- The shift of the resonance frequency of both cavities before and after coupling are within the 0.2 % range.

This means that it makes sense to tune both structures individually first, while the coupling hole has to be kept open in both cases.

- The 4-rod-RFQ provides powerful tuning capabilities along the whole structure by the tuner plates at the bottom of each RF cell between two neighbored stems. The tuner configuration as shown in Fig. 3 is valid for the matched coupled case (orange bars). It had to be slightly modified against the separated RFQ-tuning to get a reasonable voltage distribution along the RFQ in the coupled case (resonance frequencies of cells close to the IH-cavity had to be increased to reduce the voltage amplitude in the coupling zone).
- From tuning experience it was decided to provide an RF tuning range of 0 to +1 % in resonance frequency for the IH cavity by capacitively acting plunges.

HEAT DISTRIBUTION

The heat distribution is shown in Fig. 4 for the IH-DTL and in detail for the IH-tube no. 6. The thermal losses in the IH-DTL are 75 kW. All components of this structure are water cooled to dissipate the losses. Half of the thermal losses are dissipated in tank, girder and steerer at an averaged temperature increase of 7 K. A temperature increase between 20 and 40 K is seen along the stems and tubes (Table 2). For reasons of mechanical stability the stems and drift-tubes are made from stainless steel with a wall thickness of 1.5 mm. IH-tube no. 6 is the component with the highest surface currents and a heat load of 3.2 kW. The highest surface currents are on the stem surfaces pointing towards the cavity end wall: Here the cavity magnetic field of the H_{110} -mode is pointing perpendicular to the beam axis, closing the field lines from the upper and lower half of the cavity. The direct water cooling of each

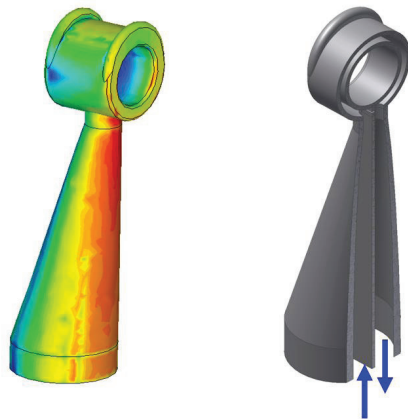
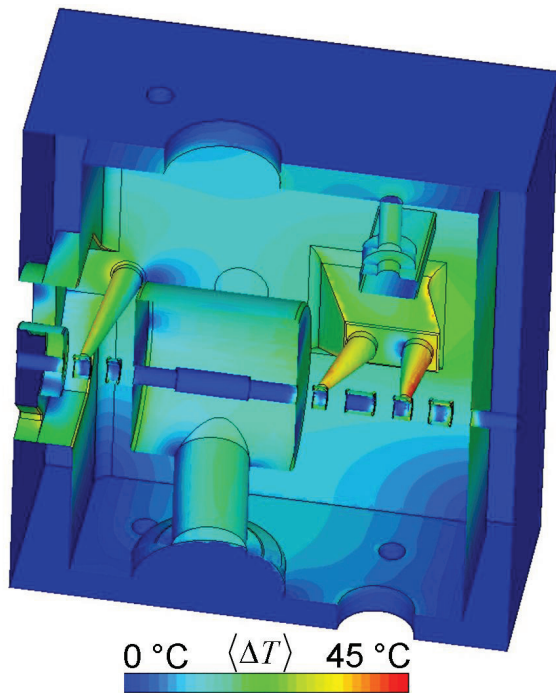

Figure 4: The heat distribution is shown for the IH-DTL (top). All surfaces of the IH-DTL are directly water cooled to remove the heat load efficiently. The heat distribution in detail for the IH-tube no. 6 and the cooling concept are shown below. The water flows along the stem around the tube and back.

stem and drift tube is needed in this case to allow cw operation at gap voltages amplitudes of up to 300 kV.

CONCLUSIONS

Combinations of RFQ-sections and DTL-sections into a coupled cavity are investigated at several laboratories currently. Main problems are the very different capacitive load per meter in these sections leading to nontrivial rf coupling scenarios. The Frankfurt coupled cavity shows promising features in simulations and RF model investigations. The power cavity is under construction and will be tested with

ISBN 978-3-95450-122-9

Table 2: Parameters of power losses and heat distribution

Parameter	P_{norm} [kW]	$\langle \Delta T \rangle$ [K]
Tube + Stem 1	2.9	23.6
Tube + Stem 2	4.6	31.3
Tube + Stem 3	3.2	30.8
Tube + Stem 4	3.8	33.0
Tube + Stem 5	3.3	38.6
Tube + Stem 6	3.2	44.7
Lens	5.8	4.8
Tuner	1.4	4.7
Tank, Steerer, Girder	35.9	7.0

intense pulsed beams from the FRANZ 120 keV high voltage platform. Due to the very demanding beam current request of up to 140 mA for experiments it was decided to stage the project: In a first step, RFQ electrodes for a design current of 50 mA will be realized, which already allows an attractive nuclear astrophysics program at FRANZ for several years.

REFERENCES

- [1] U. Ratzinger, B. Basten, L.P. Chau, H. Dinter, M. Droba, M. Heilmann, L. Lotz, D. Mäder, O. Meusel, I. Müller, Y.C. Nie, D. Noll, H. Podlech, A. Schempp, W. Schweizer, K. Volk, C. Wiesner and C. Zhang, The Driver Linac of the Neutron Source FRANZ, Proceedings of IPAC12 Conference, WEPS040.
- [2] A. Bechtold, A. Schempp, M. Vossberg, Recent High Power RFQ Development, Proceedings of International Topical Meeting on Nuclear Research Applications and Utilization of Accelerators, 4-8 may, 2009, Vienna, Austria.
- [3] U. Ratzinger, Effiziente Hochfrequenz-Linearbeschleuniger für leichte und schwere Ionen, Habilitationsschrift, Goethe Universität Frankfurt, 1998.
- [4] CST MicroWave Studio, www.cst.de.
- [5] U. Ratzinger, High Current IH Structures, Proc. of the 1994 EPAC Conf., London, Vol. 1, p. 264
- [6] L. Lu, T. Hattori, N. Hayashizaki, Design and Simulation of C^{6+} hybrid single cavity linac for cancer therapy with direct plasma injection scheme, NIMA 688(2012)11-21.
- [7] A. Bechtold, U. Bartz, G. Clemente, M. Heilmann, P. Kolb, H. Liebermann, D. Mäder, O. Meusel, H. Podlech, U. Ratzinger, A. Schempp, C. Zhang, A coupled RFQ-drift tube combination for FRANZ, Proceedings of LINAC08, Victoria, Canada, MOP001, p.46.
- [8] D. Mäder, Kopplung der Beschleunigerkavitäten RFQ und IH-DTL am FRANZ-Projekt, Master Thesis, Uni. Frankfurt, 2011.
- [9] M. Schwarz, Hochfrequenzabstimmung und Feldoptimierung des gekoppelten 1:2 RFD-IH-Modells für FRANZ, Bachelor Thesis, Uni. Frankfurt, 2012.