

MULTI-OBJECTIVE GENETIC OPTIMIZATION OF LINAC BEAM PARAMETERS FOR A SEEDED FEL

Marco Apollonio*, Riccardo Bartolini, Ian Martin,
Diamond Light Source, Oxfordshire, OX11 0DE, United Kingdom

Abstract

The optimization of the beam dynamics in a Linac for free electron lasers (FELs) can be a very time consuming process, in which several parameters of the acceleration and compression sections need to be varied simultaneously. The optimization procedure is required to tackle different and often opposing goals at a time, depending on the adopted FEL scheme. As such, multi-objective genetic algorithms are an interesting choice, given their ability to target several, often conflicting objectives. We have studied an optimization strategy based on a combination of multi-objective optimization with a fast parallel computation of the FEL performance and, for the specific case of the proposed UKs New Light Source (NLS), we illustrate the benefits of this method for the optimization of the average gain length and its variation along the beam pulse. The method can be extended to other sets of objectives, such as power and bandwidth of the FEL.

INTRODUCTION

X-ray free electron lasers are the natural evolution of 3rd generation light sources towards brighter, shorter and fully coherent photon pulses. The presently operating machines (see *e.g.* [1]) represent not only a proof of principle but established tools for new science. A typical structure adopted in these projects consists of a high brightness electron gun, a linear accelerator used to reach the final energy, and are equipped with few compression stages to increase the bunch peak current. A properly optimized linac section should maintain a high brightness throughout. The required linac tuning depends on the kind of lasing we want to achieve. In the simplest scheme, the self-amplified spontaneous emission (SASE), a large peak current, small energy spread and small normalized emittance are key elements. Any portion of the bunch with a length equal to the FEL cooperation length and with the aforementioned beam qualities, will contribute to an independent SASE pulse with its saturation length and limited time coherence. In order to improve the performance of a SASE scheme a seeding laser can be used. In the seeded mode of operation, the temporal coherence can in principle be extended to the length of the seed pulse. However this mode demands a higher beam quality control over a wider region of the pulse length. Proposed schemes like high gain harmonic generation (HG), cascaded HG or ECHO enabled harmonic generation (EEHG) all require a careful control over the energy spread. Beam uniformity beyond the full seed length both in terms of current and emittance is also

an important asset. In general the length of the uniform portion of the beam should be larger than the seed laser pulse, in order to take into account the unavoidable arrival time jitter between the electron bunch and the laser pulse. In this way one makes sure that the laser seed is always overlapping a uniform region of the electron bunch.

In order to reach this, beam dynamics needs to be optimized by means of start-to-end simulations, taking into account collective effects like coherent synchrotron radiation (CSR), longitudinal space charge (LSC) and transverse and longitudinal wakefields present in the accelerating stages. Usually a large number of often correlated machine parameters need to be varied while the resulting objective functions can be mutually conflicting (*e.g.* high peak current and current uniformity in a bunch). Multi-objective genetic algorithms (MOGA) represent an interesting approach to this class of optimization problems, and as such have been already used to characterize accelerators in many different cases (see *e.g.* [2]).

In this paper the stress is on the use of a MOGA for the tuning of a seeded FEL linac. Even though focused on the specific design for the New Light Source, the strategy adopted here can be easily ported to another machine.

OPTIMIZATION FOR THE NLS LINAC

The NLS was a project for a 4th generation light source comprising three seeded FELs driven by a single 2.25 GeV superconducting linac [3]. The baseline set-up diagram is shown on Fig. 1 together with the most relevant parameters of the machine. More details can be found in [4]. Downstream of the main linac a collimation section and a spreader section are used to remove the beam halo and off-momentum electrons respectively and to bring the beam to the three FELs.

Objectives and Optimization Procedure

The universal figure of merit describing the exponential amplification in a high gain FEL is the non-dimensional Pierce parameter ρ [5]. Another important figure related to ρ is the gain length, which describes the power growth in the undulator section and can be expressed in the 1-D model, by:

$$L_g = \frac{\lambda_u}{4\pi\sqrt{3}\rho} \quad (1)$$

where λ_u is the undulator period. A more realistic expression for the gain length, which takes into account the average size, emittance and energy spread of the beam is given by the Xie parametrization [6]. Both SASE and seeded modes require good electron bunch quality to deliver the shortest possible gain length. In the seeded case

* marco.apollonio@diamond.ac.uk

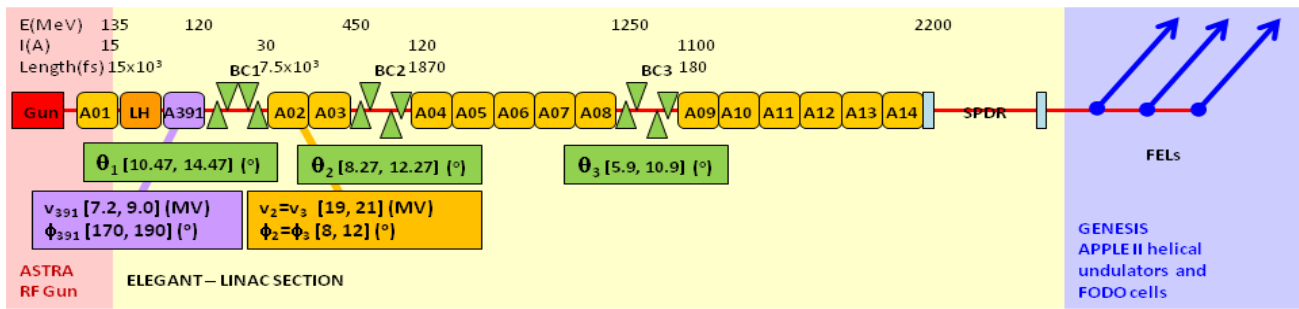

Figure 1: Layout of the NLS linac with three bunch compressors, naming convention and scope for the optimization parameters. The main sections of the system are highlighted together with the settings of every section and the relevant codes used for their description.

it is also preferable to reduce the gain length rms spread over the electron bunch. For our computing purposes we split the machine in three sections: the injector, where the beam dynamics is dominated by low energy transverse space charge forces, the linac, where acceleration and compression need to take into account CSR, LSC and wakefields, and the undulator section, where the lasing takes place. ASTRA is used for the injector simulation, ELEGANT for the linac section and GENESIS for the FEL. In the optimization the knobs used are the strength of the three bunch compressors ($\theta_1, \theta_2, \theta_3$), the amplitude and phase of the 3rd harmonic cavity (V_{391}, ϕ_{391}) and of the first accelerating cavities ($V_1 = V_2, \phi_1 = \phi_2$) as summarized in Fig. 1. The objectives are the gain length and its flatness over a time window of 100 fs around the bunch centre of charge. This value has been chosen after studies have shown that a laser seed pulse with a relative jitter of 20 ns FWHM can be accommodated within such a time span [3]. The aforementioned objectives appear to be inversely correlated, in that a low gain length is usually associated with a large variation of the same quantity along the bunch length. This feature suits well with a MOGA approach, such as the Non-dominated Sorting Genetic Algorithm (NSGA-II) adopted for our study [7]. NSGA-II finds Pareto-optimal solutions none of which is dominated by the others. The population is given a Pareto rank, that is a fitness order by the number of strictly dominating solutions. After this sorting procedure the population goes through tournament selection, polynomial mutation, and binary crossover, generating new solutions by combining the characters of the fittest parents. The least fit offsprings are discarded. The zero-ranked Pareto front is the result of the optimization after N iterations. The NSGA-II algorithm has been implemented in PYTHON and relies on message passing interface (MPI) to distribute population members across the computing cores of the Accelerator Physics (AP) cluster. The AP cluster at Diamond runs Sun Grid Engine and has 30 nodes, each with 2 quad core Xeon E5430 processors and 16 GB of RAM. Twenty-four nodes are 4xDDR Infiniband enabled to improve the performance of MPI jobs such as GENESIS. The cluster has shared access to a 200TB Lustre parallel file system. The beam dynamics simula-

tion in a linac requires a large number of macroparticles to overcome an instability effect originated by numerical noise. Also, a complete characterization of the FEL interaction would demand a time-dependent simulation. Both requests result in a very challenging scheme for a MOGA optimization, with an overall prohibitive computation time. We therefore adopted the following strategy: (a) track 10^5 particles through the linac, (b) adopt a bunch slice analysis with time-independent simulations. For part (a) we verified that the quality of solution is preserved when increasing the number of macroparticles up to 2×10^6 . In part (b) we felt the intrinsic limitations of the usually adopted Xie approach, neglecting beam size variation along the undulator train and beam angles and offsets, could be overcome by computing the FEL gain length by using GENESIS in time-independent mode. We divide the bunch into forty slices

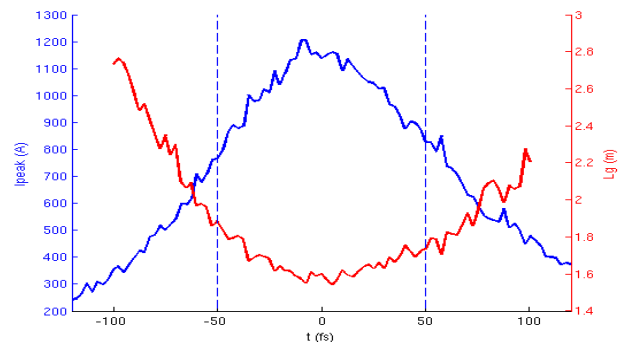

Figure 2: (blue-left vertical axis) bunch current as a function of time for a MOGA solution. (red-right vertical axis) gain length per slice. The vertical dashed lines define the r.o.i. where the average L_g and its RMS are computed.

of 2.5 fs^{-1} around the centre of charge and treat each slice as a single GENESIS run, where slice emittance, peak current, relative energy spread, Twiss parameters, offset and angles are taken into account. The resulting average and forty gain lengths and its rms are our objectives: ($\langle L_g \rangle, \sigma_{L_g}$). Fig. 2 shows a typical peak current shape as a func-

¹comparable to the cooperation length

tion of time (left vertical axis) compared to the gain length per slice (right vertical axis) for a MOGA solution. With such a choice of objectives and knobs the AP cluster can compute a full front with a population of 100 individuals in 23 minutes.

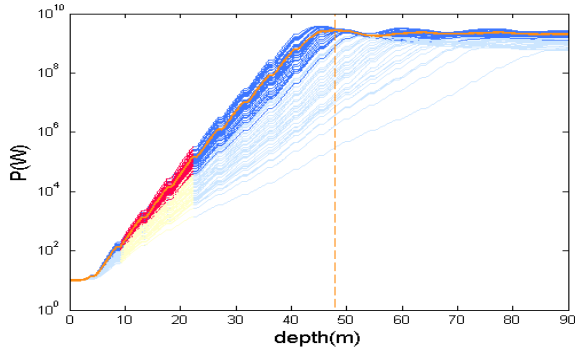

Figure 3: Determination of (L_g, σ_{L_g}) for a 100 iteration front MOGA solution. Power as a function of the undulator length as computed by GENESIS for each bunch slice. Dark blue curves refer to slices within the 100 fs time window around the bunch centroid of charge; cyan curves refer to slices lying out of the aforementioned region. The slope of each power curve is calculated between 9.18 and 22.17 m (red band) and the average curve is plotted in orange.

A further aspect of the optimization is represented by the control of the energy chirp at the end of the linac section. Instead of introducing another objective we opted for the following approach: each gain length L_g is penalized as,

$$\begin{cases} L_{g,chirp} = L_g \cdot (1 + \mathcal{P}) \\ \mathcal{P} = \exp\left(\frac{\delta_n - \delta_{MAX}}{\sigma_\delta}\right) \text{ penalty function} \\ \delta_n = \frac{|\gamma_n - \gamma_0|}{\gamma_0} \text{ relative energy deviation (n}^{th} \text{ slice)} \end{cases} \quad (2)$$

where δ_{MAX} is the maximum tolerable energy deviation (usually chosen equal to the Pierce parameter) and σ_δ describes the rapidity with which the penalty function rises above unity. In this way every solution with high energy chirp is highly disfavoured in the optimization process.

Results

The MOGA optimization over $(\langle L_{g,chirp} \rangle, \sigma_{L_g})$ has been run for the NLS set-up, both for the baseline three bunch compressor case and for a version with two bunch compressors (where only six parameters are varied) [4]. In both cases we use an initial 200 pC beam. The results of the optimizations are shown in Fig. 4 where the two Pareto fronts are compared and the initial manually tuned (SOL₀) solutions are displayed too.

This diagram suggests that the additional flexibility of the third bunch compressor leads to significantly better solutions, since the Pareto-optimal front is completely dominated by the three bunch compressor case. In the two bunch

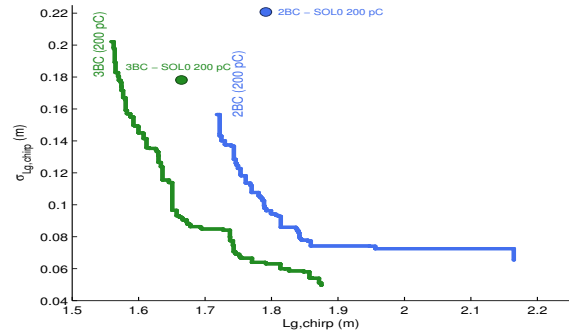

Figure 4: Comparison of the Pareto-optimal fronts for the linac with two bunch compressors (blue) and three bunch compressors (green). The large dots correspond to the starting points of a manual optimization.

compressor case it proves indeed rather more difficult to reduce the gain length without compromising the flatness, as shown by the steep rise of the Pareto-optimal front as small gain lengths are reached.

CONCLUSIONS AND FUTURE WORK

A MOGA algorithm is shown to be well suited to the complex problem of the optimization of the linac parameters for a seeded FEL. Even though the final validation needs a full numerical simulation with a larger number of macroparticles this method eases the task of designing the machine or defining new operating regimes. For the NLS set of parameters, the MOGA analysis clearly singles out a three bunch compressor design with respect to a two bunch compressor. While this result is likely to be machine dependent, both in terms of layout and initial gun parameters, we believe the strategy adopted would be of benefit to other machines.

ACKNOWLEDGMENT

We wish to thank J. Rowland for the invaluable programming support in setting up the MOGA.

REFERENCES

- [1] P. Emma et al., Nature Photon. 4, 641 (2010).
- [2] I.V. Bazarov and H. S. Padamsee, in Proceedings of the 21st Particle Accelerator Conference, Knoxville, 2005 (Ref. [12]), p. 1736.
- [3] NLS Conceptual Design Report (2010) in <http://www.newlightsource.org>.
- [4] R. Bartolini, M. Apollonio and I. P. S. Martin, Phys. Rev. Special Topics - Accelerators and Beams 15, 030701 (2012)
- [5] R. Bonifacio, C. Pellegrini, and L. M. Narducci, Opt. Commun. 50, 373 (1984).
- [6] M. Xie, Proceedings of the 1995 Particle Accelerator Conference, Dallas (1995).
- [7] K. Deb, A. Pratap, S. Agarwal, and T. Meyarivan, IEEE Trans. Evol. Comput. 6, 182 (2002).