

# BOOSTER UPGRADE FOR 700kW NOVA OPERATIONS \*

K. Seiya<sup>#</sup>, FNAL, Batavia, IL 60510, USA

## Abstract

The Fermilab Proton Source is in the process of an upgrade referred to as the Proton Improvement Plan (PIP) [1]. One PIP goal is to have Booster capable of delivering  $\sim 2.3E17$  protons/hour, 130% higher than the present typical flux of  $\sim 1E17$  protons/hour. The increase will be achieved mainly by increasing the Booster beam cycle rate from 9 Hz to 15 Hz. Beam loss due to the increased flux will need to be controlled, so as not to create larger integrated doses. The status of present operations and progress of beam studies will be discussed in this paper.

## 700KW OPERATION WITH RECYCLER AND MAIN INJECTOR

Fermilab is going to provide 700kW proton beam to the NOvA experiment [2]. Prior to the 2012 shutdown, Main Injector (MI) had been delivering 360 kW routinely and up to 400 kW of beam power to the NuMI target. Booster had injected 11 batches of  $4E13$  protons per pulse [ppp] to the MI. After the injection, the MI accelerated the beam from 8 GeV to 120 GeV every 2.2 sec.

For NOvA operation, 12 batches are injected into the Recycler Ring (RR) which is located on top of the MI in the same tunnel. The RR is an 8GeV fixed energy synchrotron using permanent magnets. Two 53MHz cavities were installed in the RR during 2012 shutdown for slip stacking. The harmonic number of the RR is 588 which is the same as MI. The MI power supply was upgraded and shortened the ramp from 1.6 to 1.33 sec as shown in Figure 1.

In the RR, 6 Booster batches are injected and then another 6 batches are injected and slip stacked. After the slip stacking, the beam density is doubled. This process takes 12 Booster cycles which is 0.8 sec.

In order to achieve 700 kW of beam power, the MI cycle has been shortened from 2.2 sec to 1.33 sec. This

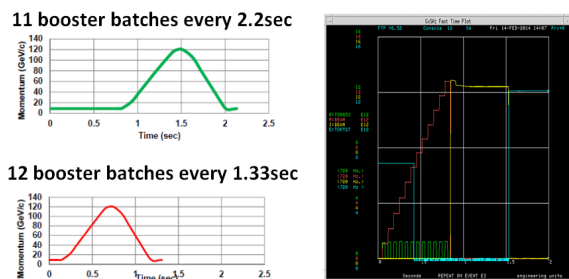

Figure 1: Left pictures; The MI ramp for 400 kW (upper) and 700 kW (lower) operations. Right picture; Intensity in the RR (red), MI (yellow) and Booster (green).

\*Work supported by Fermilab Research Alliance, LLC under Contract No. DE-AC02-07CH11359 with the United States Department of Energy.

<sup>#</sup>kiyomi@fnal.gov

was accomplished by using the RR to manage the injection and stacking of beam from the Booster while the MI is ramping.

## REQUIREMENTS FOR THE BOOSTER AND BEAM LOSS LIMIT

Booster is a 15 Hz resonant circuit synchrotron and accelerates proton beams from 400 MeV to 8 GeV. The required intensity in the Booster for NOvA is  $4.3E12$  ppp, the same as it was for 400 kW operation. However, the cycle rate will be increased from 9 Hz to 15 Hz to accommodate both NOvA and other users. The RF system and utilities are being upgraded to 15 Hz operations and are nearing completion. The plan is to start 15 Hz operations in FY15.

The beam loss limit has been set to 525W to allow workers to maintain all elements in the Booster tunnel without excessive radiation exposure. Figure 2 shows the historical beam loss in the Booster versus protons per hour. The total loss depends on the beam intensity. Given the required intensity of  $2.3E17$  protons per hour, the loss has to be reduced to half by 2016.

The present operational beam intensity at injection is about  $5E12$  ppp and extraction is  $4.5E12$  ppp. The total energy loss is 0.075 kJ in one Booster cycle and hence 1150 W when the cycle rate is 15Hz. The loss has to be reduced to half by 2016. Figure 3 shows the intensity and loss during normal operations. The points where significant beam loss occurs are when the RF feedback is turned on, when the extraction kicker gap is created and when beam acceleration passes through transition. There are slow losses from injection to 5 ms into the ramp and after transition. Beam studies and upgrades that will be done to reduce the beam losses will be discussed in this paper.

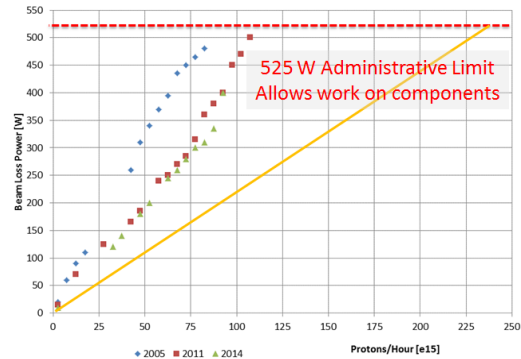

Figure 2: Beam power loss for 3 year operations (blue: 2005, red: 2011 and green: 2014)

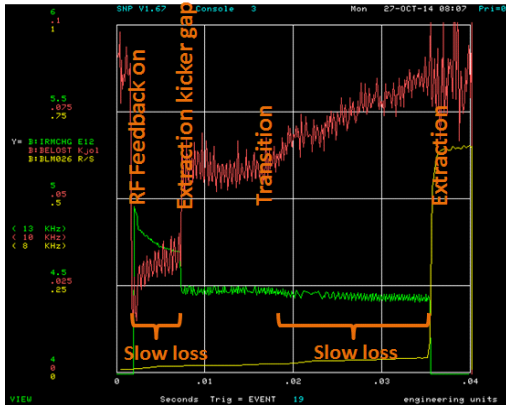

Figure 3: Beam intensity (green), energy loss (red) and extraction loss (yellow) signals.

### BEAM STUDIES AT THE BOOSTER

Booster has 24 periods. Each period consists of a 0.6 m straight section (short straight section), a focusing combined function main dipole magnet (F magnet), a defocusing main dipole magnet (D magnet), a 6 m straight section (long straight), and another D magnet and F magnet. 48 correctors were installed in the long and short straight sections in 2006. Each corrector (Figure 4) has horizontal and vertical dipoles, a quadrupole, a skew quadrupole, a sextupole, a skew sextupole and horizontal and vertical beam position monitors. Figure 5 shows the beta function and dispersion for one Booster period. The typical horizontal emittance is  $14\pi$  mm-mrad and  $16\pi$  mm-mrad vertical emittance. The RF parameters are listed in Table 1.

Table 1: RF Parameters

Energy	400 MeV – 8GeV
RF frequency	37.9 – 52.8MHz
Harmonic number	84
Maximum voltage	1MV with 19 cavities

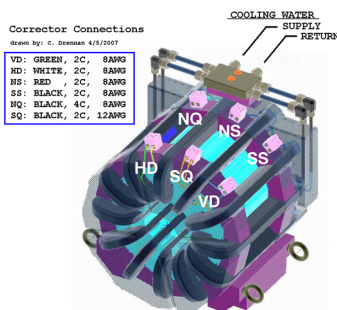

Figure 4: The corrector package is 0.6 m long.

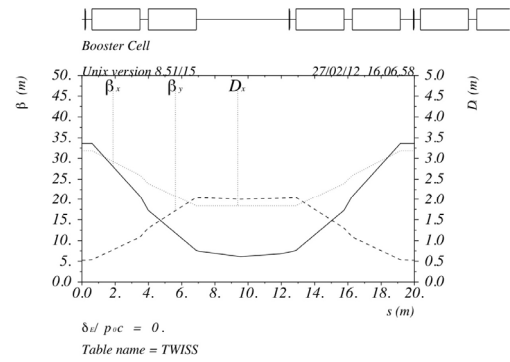

Figure 5: Booster lattice for one period.

### Aperture Scan and Magnet Moves

Horizontal and vertical beam sizes are largest at the short and long straight sections respectively. The short straight section has one corrector and all other components are in the long straight section. Booster has 19 RF cavities in the long straight sections from period 14 to 24. The diameter of the beam pipe in the RF cavities is the smallest of all the components in the long straight sections. Therefore, we find the smallest beam aperture located at periods 14 to 24 in the vertical plane.

Magnet moves were performed based on survey data and beam aperture scan results [3]. By moving more than two magnets at one time, the beam orbit was kept at the same position to within +/- 1 mm. Magnets were moved at 4 locations where RF cavities were installed. Figure 6 shows the aperture at period 16 before and after the magnets were moved. Aperture scans were done using combinations of 5 and 3 bumps. The colors represent the ratio between beam intensity sampled at injection and after the bumps were made.

Figure 7 shows the aperture before and after realignments around the ring. The apertures were larger after the realignments were done. The aperture is currently smallest at periods 6 and 7 where collimators are located. The next step is to optimize the collimator settings.

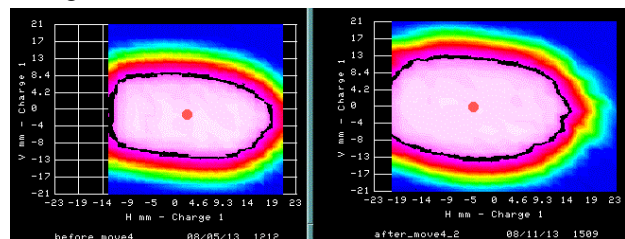

Figure 6: The aperture at injection and long 16 where RF cavities are installed.

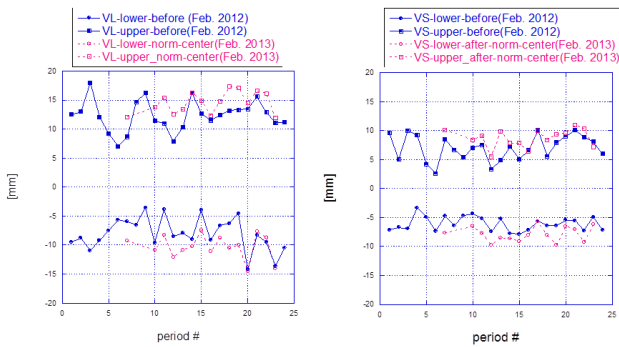

Figure 7: Vertical apertures at the long (left) and short (right) straight sections before (magenta) and after (blue) re-alignments around the ring.

**Beam Capture at Injection**

Booster is a resonant circuit synchrotron and the B field at injection is not flat. 200 MHz bunches are injected from Linac with multi turn injection which takes 40  $\mu\text{s}$ . The current mode of Booster operation has injection occurring at the minimum of the B field. The 200MHz bunches are debunched without RF voltage for 60  $\mu\text{s}$  and then adiabatically captured with 37.9 MHz RF voltage. The magnetic field ramp and frequency change happens during adiabatic capture without RF feedback. There is a beam loss at injection especially with the RF feedback turned on.

A new injection scheme has been proposed to move the injection timing earlier and remove the debunching [4]. The injected beam stays near 400 MeV until capture is done. Figure 8 shows the injection timing difference between the present scheme and the proposed scheme. Both schemes were simulated and the longitudinal phase space was compared at 400  $\mu\text{s}$  after the B field was at its minimum. Simulation results in Figure 9 show that 4% of the particles were already outside of the bucket with the present scheme. There were no particles outside of the RF bucket with the new scheme and the bunch area at the end of the capture was found to be  $\sim 40\%$  smaller than that observed with the present scheme. Consequently, the required RF power could be reduced by  $\sim 30\%$ .

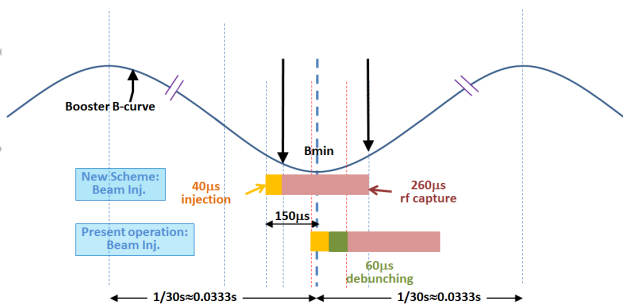

Figure 8: Injection timing for the new scheme and present operation.

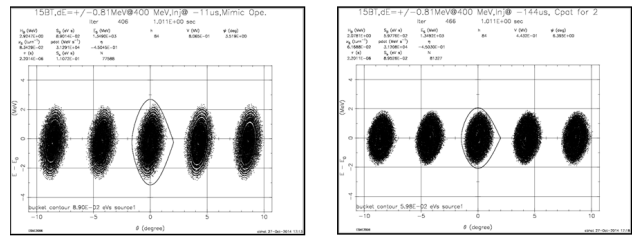

Figure 9: Simulation results for the RF capture at 400  $\mu\text{s}$  respected to the minimum B field. Present scheme (left) and proposed scheme (right).

**Cogging**

An extraction kicker gap must be created during the cycle because the beam completely fills the Booster after the multi-turn injection and adiabatic capture at the injection energy. The gap has to be synchronized to the Booster extraction kicker and RR injection kicker. The variation in the Booster main dipole fields causes errors in the gap position at extraction. Cogging eliminates this error by controlling the bucket positions throughout the cycle [5].

The gap position is controlled by changing the revolution frequency. The present cogging system changes the revolution frequency by moving radial position of the beam. Since the transverse emittance is large at low energy and any radial position change can cause beam loss. In order to reduce losses, the gap is created at 700 MeV and this is where radial position changes occur.

The new Magnetic Cogging changes the revolution frequency by changing the bend field using 48 dipole correctors. The Booster radial position feedback is regulated to a fixed radial position of the beam. Figure 10 shows how the magnetic cogging feedback system works: the revolution frequency is measured by counting Booster RF cycles within a Recycler revolution period. The counts from each period are compared with the one from the initial reference cycle and the error is integrated through the cycle. The error is the correction signal for the dipole corrector. Figure 11 shows that magnetic cogging does work by comparing the integrated errors with and without magnetic cogging.

The extraction kicker gap creation can happen at any time after injection with the new magnetic cogging system instead of only at 700 MeV with the present cogging system, therefore it will reduce beam energy loss. Since the Linac laser notcher is going to be available in 2016, the gap will not be created in the Booster.

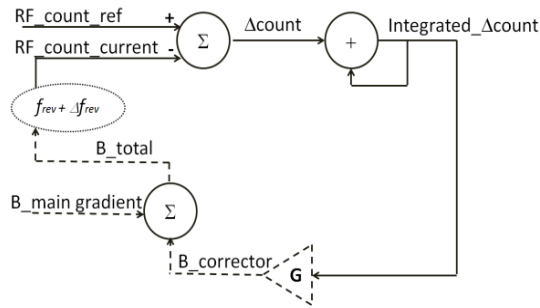

Figure 10: Block diagram of cogging feedback.

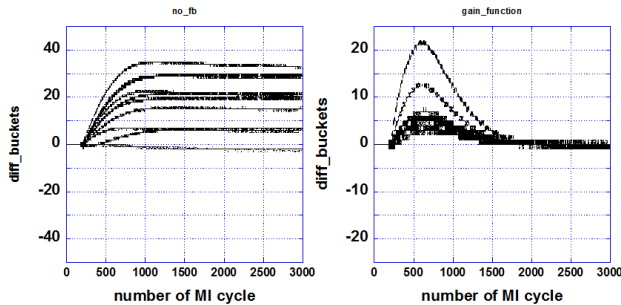

Figure 11: Integrated bucket error signal with (right) and without (left) cogging.

Optics Control

The beta functions were modulated from Injection to extraction in the Booster and it could cause emittance mismatch and thus beam loss. Figure 12 shows the comparison of the beta functions between the lattice with the injection bump turned on and the lattice after correcting the beta errors arising from this bump. These beta function errors caused by the injection bump were corrected with a set of quadrupoles around this bump [6].

LOCO (Linear Optics from Closed Orbit) calculates the quad and skew quad currents that corrects the measured lattice to make it closer to the ideal lattice. This method uses a set of kicks made at each dipole corrector and the response of the beam at every BPM was measured. The kick angle was changed by changing the corrector current so that the ratio between the position changes: dx and kick angle change: dθ could be measured at each location. Then dx/dθ was compared with the one from the ideal lattice calculated with MADX. From the difference between the measurements and the ideal lattice, the correction for the quad and skew quad was calculated using LOCO.

The beam response at every BPM to every dipole kick was measured at 7 break points from injection to extraction. Figure 13 shows the Booster lattice at injection before and after the correction in horizontal and vertical planes. It is clear that the beta errors were reduced around the ring. Studies are continuing to incorporate these corrections into the operational lattice.

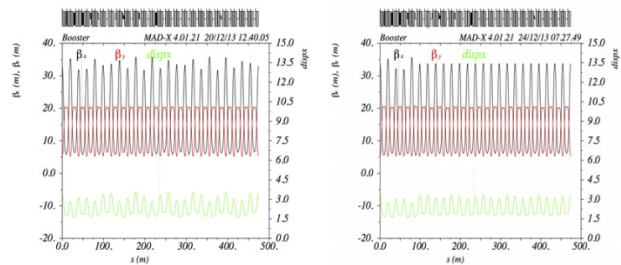

Figure 12: The calculated lattice with the injection bump turned on (left) and the corrected lattice (right).

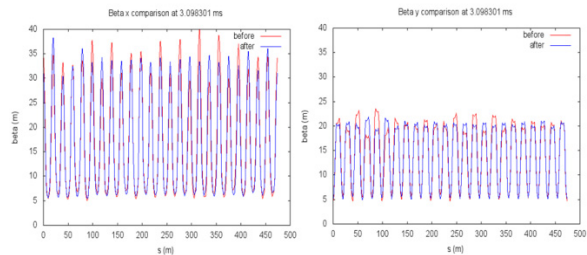

Figure 13: The measured Booster lattice at injection before (red) and after (blue) the correction in the horizontal (left) and vertical (right) planes.

Tune Measurements and Control

Tunes can now be measured from injection through extraction by transversely exciting the beam every 500 turns with a pinger (Figure 14). The tunes in the entire ramp can be set to any point in the tune plane using the new corrector quadrupoles. By setting these tunes in a controlled fashion, the beam can be moved away from resonances and thus reduce beam loss.

The coupling was also measured and it has been corrected with the new skew quadrupoles [7].

For tune measurements, the present tune monitor excites large transverse oscillations that causes beam loss for high intensity beam. In order to fix this problem, a new damper/pinger is currently being commissioned. This new tune meter uses the horizontal bunch by the bunch damper to excite just one bunch out of 84 bunches by using random noise or by anti-damping (Figure 15) [8].

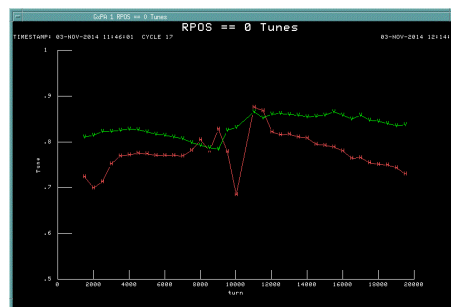

Figure 14: Horizontal and vertical tune measured by present tune monitor what uses BPMs and pinger. Horizontal tune is in red and vertical is green.

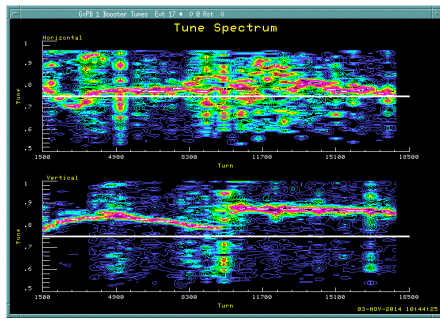

Figure 15: Horizontal (upper) and vertical (lower) tune measured by new tune monitor using damper.

### *Transition and Extraction Loss*

After the RF upgrades are complete, the RF voltage at transition is going to be increased by adding additional cavities. This will help reduce the losses and increase reliability. The extraction gap kicker and absorber upgrade has localised losses to the absorber and has reduced losses at extraction. These two upgrades are discussed in another paper in this workshop [9].

## **LOW LEVEL RF AND INSTRUMENTATION UPGRADE**

Booster has been operating since 1971 and many low level modules were developed in the 1980's and have component obsolescence issues. Upgrades to the electronics are being carefully integrated into the Booster controls.

### *LLRF*

New electronics modules have been commissioned that manage the phase locking of the Booster RF to the RR just before Booster extraction. The new systems provide slightly better performance and additional access and opportunities for further improvement.

A new four channel direct digital synthesis module is under development that will replace the LLRF frequency source and the analogue phase shift modules used for radial position control and paraphrasing of the rf cavities for beam capture. This module will provide more precision and flexibility to the LLRF controls.

### *Dampers and Instrumentations*

Booster has 8 mode dampers which damp coupled bunch modes above transition. The frontend for these analogue dampers contain obsolete components and have limited flexibility. A new digital damper card has just been completed and is undergoing initial beam tests. These new digital dampers will provide better signal to noise and gain and will be more reliable for operations.

The BPM system is going to be replaced with real time LINUX VXS and VME based systems. The new BPM system will be able to measure the beam at injection, which has 200 MHz structure, and bunched beam throughout the acceleration cycle that has 37.7 to 52.8 MHz RF structures.

### *Total Loss Monitor*

Fermilab uses interlocked ion chamber radiation detectors called chipmunks as an input to the radiation safety system. The chipmunk locations and trip settings are determined by the Shielding Assessment Process. Chipmunks are located outside of radiation shields and trip off the radiation safety system in the event the prescribed effective radiation dose rate limits are exceeded.

TLM (Total Loss Monitor) is being developed at Fermilab as an alternative input to the radiation safety system [10]. TLM is a long ion chamber (air-filled dielectric coaxial cable) filled with ArCO<sub>2</sub> detector gas. The detector is mounted in the tunnel while the associated electrometer is located outside the tunnel in a service building. A single detector can cover large sections of tunnel that is hundreds of feet in length. Beam studies to characterize the TLM response under a wide variety of beam loss conditions are ongoing.

## **SUMMARY**

The Booster cycle rate of 15 Hz and averaging 4.3E12 protons per pulse will be completed by 2016. The beam loss has to be reduced by half compared to the present situation. The ongoing PIP beam studies along with hardware and software upgrades are critical. A successful completion of the PIP effort is a laboratory priority and essential for reaching the HEP proton delivery goals.

## **REFERENCES**

- [1] W. Pellico et al., "FNAL - The Proton Improvement Plan (PIP)", THPME075, these proceedings, IPAC'14, Dresden, Germany (2014).
- [2] I. Kourbanis, "Progress Towards Doubling the Beam Power at Fermilab's Accelerator Complex", TUOAA01, IPAC'14, Dresden, Germany (2014).
- [3] K. Seiya et al., "Alignment and Aperture Scan at the Fermilab Booster", THPPP024, IPAC'12, New Orleans, USA (2012).
- [4] C. S. Bhat, private communication.
- [5] K. Seiya et al., "Development of Cogging at the Fermilab Booster", WEPR069, IPAC'14, Dresden, Germany (2014).
- [6] C. Y. Tan, private communication.
- [7] W. Marsh et al., "An application for tunes and coupling evaluation from turn by turn data at the Fermilab Booster", MOP221, PAC2011, New York, UAS (2011).
- [8] N. Eddy et al., "Using the transverse digital damper as a real-time tune monitor for the Booster synchrotron at Fermilab," MOPD71, DIPAC'11, Hamburg, Germany (2011).
- [9] R. Zwaska et al., "Enhancements of the Fermilab Booster to reduce losses and extend lifetime: The Proton Improvement Plan", MOXAP07, these proceedings, HB2014, Lansing, UAS (2014).
- [10] T. Leveling, private communication.