

PLC- AND SCADA-BASED EQUIPMENT PROTECTION SYSTEMS FOR THE NEW BEAMLINES AT BSRF

Shenshou Xiong, Yinglei Tan, Weidong Man and Yang Yang
 Beijing Synchrotron Radiation Laboratory
 Institute of High Energy Physics
 P.O. Box 918, Branch 2-7, Beijing 100039, China

Abstract

The three new front ends (one bending magnet front end and two wiggler front ends) and four beamlines, were constructed and were in operation at BSRF (Beijing Synchrotron Radiation Facility) in 2002. At the same time, the three new Equipment Protection Systems (EPS) for the beam lines were designed and have been in operation. Each front end and its beamlines are equipped with a new EPS designed by using a set of FX_{2N} PLC, which is used to protect the front-end and beamline components from being damaged by high power synchrotron radiation from wigglers, as well as to protect the BEPC(Beijing Electron-Positron Collider) storage ring vacuum against vacuum failures in a beamline. Each FX_{2N} PLC is only responsible for data acquisition, logic, and I/O in its own EPS system, and runs an actual interlock and control and communication program. All the new PLC- based EPSs can be used to communicate with a centralized monitoring computer to monitor a variety of parameters from each system. The monitoring computer runs another SCADA (Supervisory Control and Data Acquisition) industrial software with its own web server. Operator graphical interfaces are used to display an overall view of the front ends around BEPC storage ring, and a detailed information display for each EPS in a pop-up window, etc. In addition, all the old vacuum control and protection systems for the beamlines will be gradually replaced by the new PLC-based EPS, and will be connected to the same monitoring computer. Design of the system is described in this paper.

INTRODUCTION

At present, the BEPC is undergoing an upgrade program---BEPCII Project [1], which is scheduled to be operational in 2007. During the period of BEPC upgrade program, the three new front ends and four beamlines were designed and installed around the BEPC storage ring (see Fig.1) and were also in operation at BSRF in 2002. The new front ends are 1W1 front end for the permanent magnet wiggler and two beamlines (1W1A and 1W1B), 4W2 front end for the permanent magnet (in-vacuum) wiggler and one beamline, and 3B3 front end for the bending magnet and one beamline. Each new front end and its beamlines are equipped with a new independent Equipment Protection System (EPS), and now there are in total of seven EPSs, including the three new EPSs. In this case, it is necessary to construct a centralized monitoring system to supervise all the EPSs.

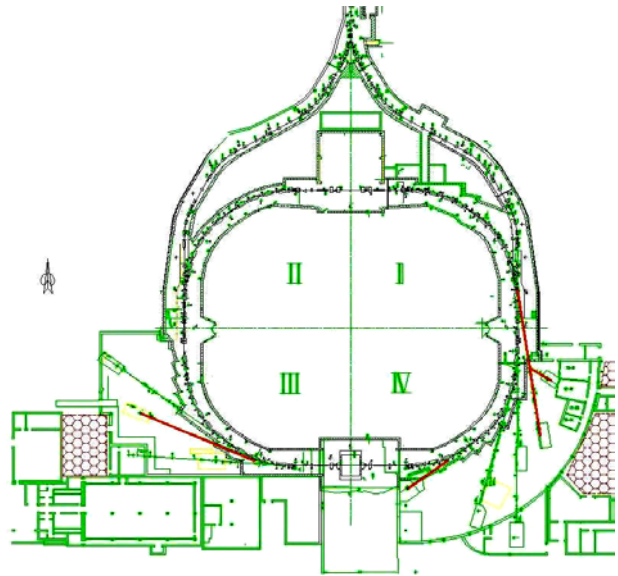

Figure 1: Three new front ends and four beamlines around the BEPC storage ring.

POWER FROM THE WIGGLERS

The BEPC storage ring is currently operated at the electron energy of 2.2 GeV and beam current of 120 mA under dedicated synchrotron radiation mode. However, after upgrade, the wigglers 1W1 and 4W2 will produce high power and high intensity synchrotron radiation. The calculation of power radiated from the wigglers is generally related with the wigglers parameters [2]. The total power P_T and maximum power density P_D radiated from the wigglers 1W1 and 4W2 were calculated respectively in the BEPCII different operation modes. The P_D is the radiated power per unit solid angle. The calculated results are listed in table 1.

Table 1: P_T and P_D of the 1W1 and 4W2

	E (GeV)	I (mA)	P_T (KW)	P_D (KW/mrad ²)
1W1	2.8	200	3.14	1.38
	2.5	300	3.75	1.28
4W2	2.8	200	7.73	3.22
	2.5	300	9.24	3.07

DESIGN OF THE PLC-BASED EPS FOR HIGH-POWER WIGGLER BEAMLINES

Design requirements for the new PLC-based EPS are not only suitable for BEPC operation mode, but also meet BEPCII operation modes in 2007. Fig.2 is the design of a typical PLC-based EPS system for 1W1 high-power beamlines.

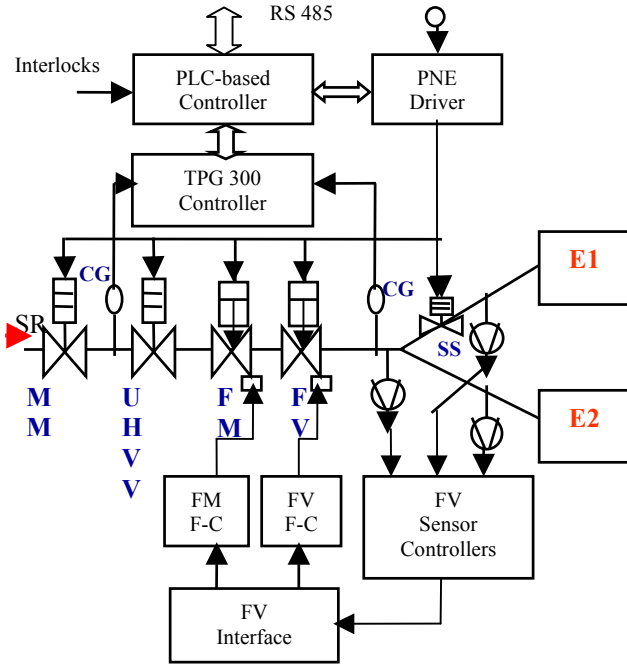

Figure 2: Schematic block diagram of a typical new PLC-based EPS system for 1W1 high-power beamlines: (SR) synchrotron radiation, fast valve (FV), fast mask (FM), movable mask (MM), UHV valve (UHV), (CG) cold cathode gauge, (FV-FC) fast valve firing circuit, (FM-FC) fast mask firing circuit, (SS) safety shutter, (PNE Driver) pneumatic driver for the valves and safety shutters, (E1, E2) experimental station 1 and 2.

One of the major considerations for the EPS design was how to protect the fast valve (FV) from high-power synchrotron radiation when it is triggered to close. In order not to make the FV be damaged by high-power synchrotron radiation, a fast mask (FM) with closure time of 50 ms is installed in front of the FV. The FV (6.5 milliseconds for the closure time) has a titanium-alloy blade with the melting point of 1680 °C, and the (water-cooled) movable mask (MM) with closure time of 2 seconds is used to protect FM and UHV valve (UHV) from overheating. The UHV valve is the primary vacuum isolation valve between the storage ring and the beamlines, and then two cold cathode gauges (CGs) are used to monitor two sides vacuum of the UHV valve. The process control pressure relays of the cold cathode gauges (TPG300) Controller are interlocked with the UHV valve via the PLC-based controller. When one of the two CGs is over 1×10^{-7} Torr due to slowly rising pressure, The PLC-based controller will make the UHV valve and the MM

close automatically, generating a high-pressure alarm signal at the same time.

If the pressure at any one of the fast valve sensors (1millisecond response time) is above 1×10^{-4} Torr, the FV and FM (fast mask) will be triggered to close without the need for aborting electron beam running in the storage ring. Triggering the FV and FM simultaneously close, the MM and the UHV valve will also automatically close under the interlock controls of the PLC-based controller. For the 3B3 bending magnet beamline, the PLC-based EPS has no the FM, but the design is much the same with 1W1 beamlines.

In addition, each PLC-based EPS has its own cooling-water interlock system. The cooling-water flow for all the water-cooling components is monitored by the flow sensor pressure switches, which are directly wired to another PLC. The PLC-based controller will close the MM (movable mask) located in front end when a cooling-water failure is detected by one of the flow sensors, thus shielding the water-cooled component surface from synchrotron radiation.

SCADA-BASED CENTRALIZED MONITORING SYSTEM

The basic hardware configuration of the centralized monitoring system is shown in Fig.3. The monitoring computer (Pentium IV) is used to collect and log data, and to display the real-time operation status from each PLC-based EPS.

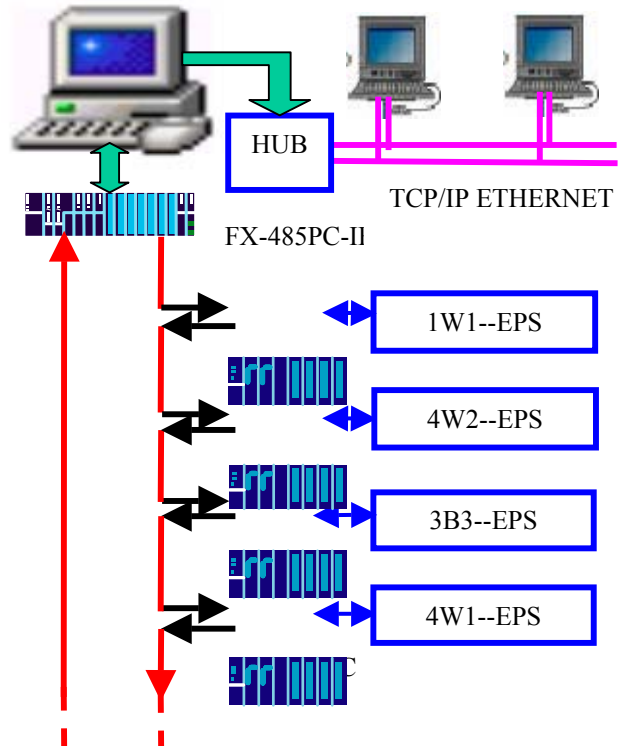

Figure 3: Block diagram of the hardware configuration for the centralized monitoring system.

The monitoring computer is serially connected with each set of the PLC-based EPS via the RS232/RS485

converter (FX-485PC-IF) and an RS485 interface (FX_{2N}-485-BD). The new PLC-based controller includes the main FX_{2N}-PLC with 120 I/O points, an ADC module (FX_{2N}-4AD) with 4 input channels, and an RS485 interface. The input points are used to acquire status from the field devices (e.g., positions of water-cooled movable mask, all-metal UHV valve, fast valve and fast mask, as well as output relays of TPG300 controller with two cold cathode gauges (CGs), pressure switches for cooling-water flow sensors, etc.). The ADC channels are used to read the analogue output voltages from the TPG300 controller. Each new PLC-based controller is installed in a separate equipment chassis, and the operating panel is installed in the front of each chassis for local operation, and all the old PLC-based EPSs with RS-485 interface will be gradually connected serially to the same centralized monitoring computer on schedule.

SCADA systems are now widely used in industry and experimental physics control systems for supervisory control and data acquisition of processes. Because SCADA have all possible types of connectivity and integration, and also is the quickest and easiest way to develop human machine interface (HMI) applications for all the PLC-based EPSs, the Chinese SCADA [2] industrial software with its own web server (ForceControl Co. China) was chosen to use as the monitoring software platform. The SCADA runs on the centralized monitoring computer, and each PLC-based EPS is only responsible for data acquisition, logic, and I/O in its own EPS system, and runs an actual interlock and control and communication program. Thus, even if the SCADA level fails, the PLC driven part of the interlock and control system for each new PLC-based EPS can still work well. In order to provide the functional, flexible, and graphic HMI for the monitoring system, the graphical display with an overall view of seven front ends around BEPC storage ring was developed (see Fig.4), and open or closed position status of the valves and masks for all the front ends are displayed. In the overall view, the button icons corresponding to each PLC-based EPS and a vacuum pressure display overall view for all the front ends were also developed.

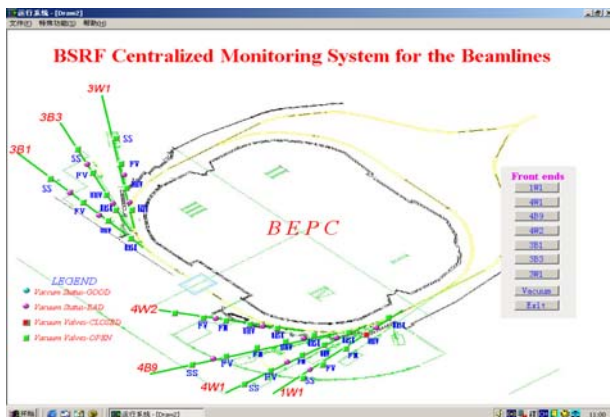

Figure 4: Graphical display for an overall view of all the front ends around BEPC storage ring.

When one of the button icons is clicked, the corresponding pop-up window with further detailed information will be opened. For example, when 1W1 button icon is clicked, the pop-up window with detailed information for 1W1 PLC-based EPS will arise, which is shown in Fig. 5.

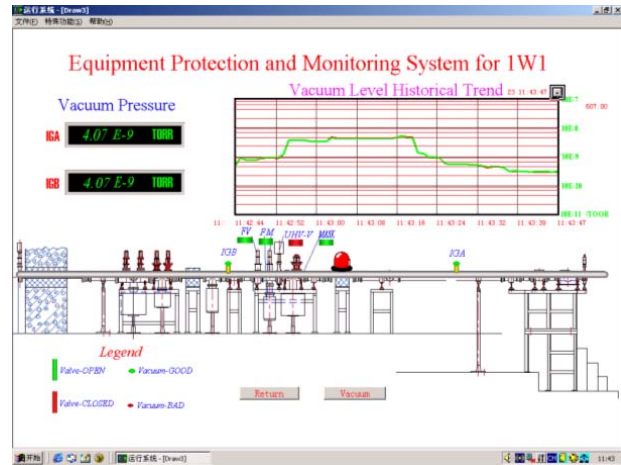

Figure 5: Graphic display for 1W1-EPS. Vacuum pressure, pressure historical trend and open or closed positions of valves and masks for 1W1 front end are displayed. Color is used to indicate position status of the valves and masks, such as, red = closed and green = open.

The SCADA used in the monitoring system, is a type of web enabled SCADA software. On the web services, the SCADA-based monitoring system provides a web browse function using a web browser (Internet Explorer).

CONCLUSIONS

In this design, the PLC-based EPS can both protect the storage ring vacuum from any vacuum failures in a beamline, and can avoid the FV blade to be damaged by high-power synchrotron radiation without the need for aborting electron beam running in the storage ring. The SCADA provides multipurpose utility management and operating flexibility for the monitoring system. However, development of the other monitoring functions (such as alarm system etc.), as well as complete commissioning of the systems, are currently in progress.

REFERENCES

- [1] Feasibility Report on BEPCII Project, BEPC/IHEP Report (2001).
- [2] Caitu Shi and Yonglian Yan, "Present status of insertion devices at the BEPC", Proc. of the Second Asian Particle Accelerator Conference, P.259-261, Beijing, China, 2001.
- [3] User's manual for the SCADA, ForceControl Co. China.