

DUAL-AXIS ENERGY-RECOVERY LINAC*

Chun-xi Wang[†], John Noonan, John W. Lewellen[‡]
Argonne National Laboratory, Argonne, IL 60439, USA

Abstract

In this paper we propose a new type of energy-recovery linac (ERL) for ERL applications. The envisioned dual-axis energy-recovery linac allows energy recovery of parallel beams, accelerating/decelerating along different axes, via the same dual-axis superconducting cavity. This new scheme offers many advantages over conventional ERLs in various applications. Preliminary feasibility considerations are presented.

INTRODUCTION

The high-intensity energy-recovery linac is becoming a promising technology for many applications from free-electron laser and synchrotron-radiation-based light sources to high-energy nuclear physics facilities. In an energy-recovery linac, a beam makes at least two transits through the linac: one pass for accelerating a high-quality beam, the other for decelerating the spent beam to recover the beam energy. Currently, most energy-recovery linac designs use standard TM_{01} -type accelerating structures, in which beam must pass along the same accelerating axis and thus occupy the same transverse position. Here we propose to develop a novel superconducting rf cavity that has two equivalent accelerating axes such that the accelerating and decelerating beams can go through different axes while the energy recovery is still performed within the same physical cavity. Such a new cavity structure will enable a dual-axis energy-recovery linac (DERL). As an illustration of the concept, Fig. 1 shows the electric field of the accelerating mode in a dual-axis single-cell cavity that will be discussed later. Locally along each of the two beam pipes, the rf field resembles the standard TM_{01} accelerating mode and thus provides two independent accelerating axes, yet the two beams can transfer power between them through the common eigenmode of the cavity.

The dual-axis energy-recovery linac concept appears similar to the two-beam accelerators (TBAs) for high-energy particle physics, which have been pursued for a few decades and are currently undertaken by the CLIC test facility at CERN. Many TBA schemes have been proposed over the years (e.g., [1], [2]), but with a basic common feature: a very-high-intensity low-energy beam is used as the drive to power a high-gradient rf structure for accelerating a high-energy beam. Although TBAs transfer energy from one beam to another parallel beam just like DERL is sup-

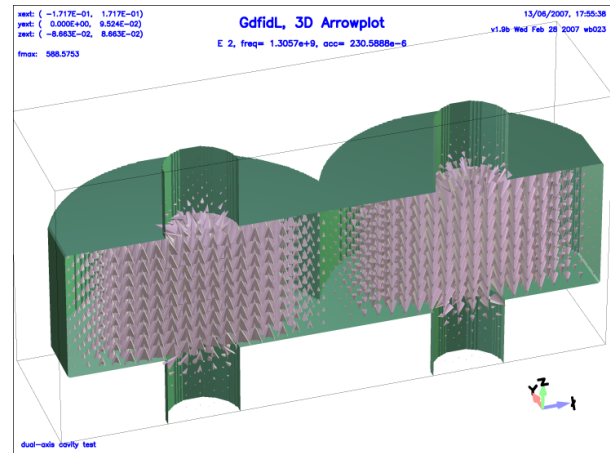

Fig. 1: A conceptual dual-axis single-cell cavity.

posed to do, they are very different. In DERLs, there are external rf sources to power (and control both phase and gradient) the accelerating mode, through which energy recovery is achieved. The effective beam loading in DERLs is small because the two beams have the same intensity and deposit/withdraw roughly the same amount of power from the cavity rf field. The required rf field gradient is much more moderate in DERLs than in TBAs for high-energy colliders. Furthermore, ERL applications focus on high-average current, steady-state operation. These major differences make the DERL accelerating structure much more feasible.

Another closely related idea was the energy recovery of two standard (normal conducting) linacs coupled through resonant bridge couplers, as demonstrated by the Los Alamos free-electron laser energy-recovery experiment [3] 20 years ago. However, the DERL we are proposing is more of a unified dual-axis linac with a single eigenmode for accelerating two beams, which could be critical for the stability of the accelerating field and energy-recovery efficiency. Further studies are needed to validate either approach for high-power superconducting ERL applications.

In the following, we first address the many advantages DERLs have over a standard ERL. Then we present some preliminary thoughts on the feasibility of such a new linac.

ADVANTAGES OF DUAL-AXIS ERL

We consider three basic geometries for DERL applications. One has the accelerating and decelerating beams co-propagating using different axis. Another has two beams counter propagating. The third has four beams, two on

*Work supported by U.S. Department of Energy, Office of Science, Office of Basic Energy Sciences, under Contract No. DE-AC02-06CH11357.

[†] wangcx@aps.anl.gov; <http://www.aps.anl.gov/~wangcx>

[‡] Northern Illinois University as well as ANL

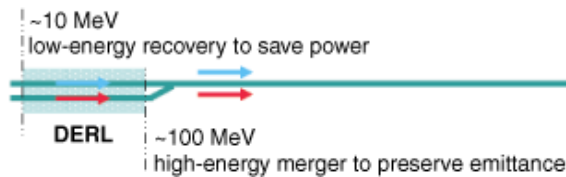

Fig. 2: DERL as a solution for beam merger. The red arrow indicates accelerating beam.

each axis, and achieves energy recovery either within the same-axis beams or between the two axes.

A solution for beam merger

To achieve energy recovery in a standard ERL, a fresh low-energy beam needs to be merged with the spent high-energy beam at low energy in order to avoid beam power costs for operation. For example, at 100 mA, a merger at 10 MeV means 1 MW of unrecovered beam power. On the other hand, to take advantage of an ERL for high-brightness light sources, very low emittance beams from photoinjectors are required. However, with the low emittance comes the detrimental space-charge effects that fade away at an energy given by [4]

$$\beta\gamma = \frac{\kappa_s}{\epsilon_n \sqrt{\kappa}} \simeq \sqrt{\frac{8}{3}} \frac{\kappa_s}{\gamma' \epsilon_n}, \quad (1)$$

where ϵ_n is normalized emittance, $\kappa_s = I_{\text{peak}}/2I_A$ is beam perveance ($I_A = 17\text{kA}$ is the Alfvén current), and γ' is the accelerating gradient in the booster. For envisioned high-brightness x-ray light source applications, this leads to an energy on the order of 100 MeV, below which the beam is vulnerable to bending and asymmetric focusing in a beam merger. A few merger schemes [5] have been studied to overcome this problem, yet none of them have been demonstrated successfully (even in simulations) for preserving beams to the level of $0.1\text{-}\mu\text{mrad}$ emittance envisioned for major x-ray light sources [6, 7].

A DERL can be used to recover beam energy without merging the two beams on the same axis, thus providing a solution to the challenge of merging a vulnerable high-brightness low-energy beam with the energy-recovery beam. This can be achieved by avoiding the merge completely (if the DERL turns out cost-effective as the main linac) or by merging at much higher energy, as illustrated in Fig. 2. As a solution for beam merger, the cost of a DERL is less of a concern, and the accelerating and decelerating beams may go in the same direction as shown in Fig. 2 or in the opposite direction. Therefore, a DERL will be useful as long as a dual-axis cavity proves feasible.

Another potential benefit of a DERL, as R. Rimmer commented, is the possibility of making the decelerating cell larger than the accelerating cell to accommodate the larger spent beam (although the energy spread is probably a bigger problem).

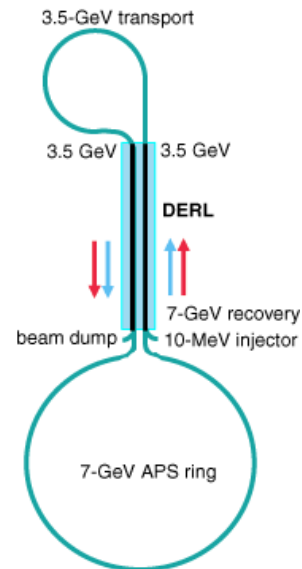

Fig. 3: DERL as a recirculating linac. It functions as two separate ERLs with no power transfer between the two axes.

As a recirculating energy-recovery linac

For the envisioned ERL-based future high-brightness x-ray light sources, several-GeV and 100-mA beam is needed to significantly outperform storage-ring-based third-generation light sources [7]. Such a high-energy, high-average-power, superconducting linac costs a great deal to construct and operate. One possible cost-saving scheme is to use the same linac twice (or more) in a recirculating energy-recovery configuration, in which four beams pass through the same linac simultaneously for recirculating and energy-recovery of the same beam. The main challenge for such a scheme is the potential beam breakup due to multiple passes with a effective beam current twice as much as in a full-energy ERL. Furthermore, the optics becomes more complicated/costly not only in the linac to provide focusing simultaneously for several different beam energies, but also in the beam transport lines to implement recirculating and energy recovery.

A DERL can be used as a recirculating energy-recovery linac, as illustrated in Fig. 3, which was proposed as a potential alternative for an ERL upgrade of the Advanced Photon Source (APS) [7]. In this case, one DERL functions as two separate ERLs and thus avoids all the difficulties incurred due to recirculating in a single standard ERL. Furthermore, beam transport becomes much simpler and cost-competitive. However, a DERL will clearly cost more than a single ERL, but could still be significantly less than two separate ERLs that are effectively replaced by the DERL. Therefore, in addition to DERL feasibility, the exact cost factor between a DERL and an ERL will be critical to the usefulness of a DERL as a main recirculating energy-recovery linac. The potential cost benefit makes the DERL worthy of serious investigation.

DERL with counter-propagating beams

A DERL may also facilitate energy recovery between counter-propagating beams passing through separate axes. As an energy-recovery linac with counter-propagating beams, it allows better/easier transverse optics because at each longitudinal location, the accelerating/decelerating beams have the same energy; thus there is no need for the so-called “graded-gradient” focusing optics. As a result, better control of transverse beam size can be achieved, which can reduce beam loss due to beam halo, etc. Possibility of a counter-propagating-beam DERL offers more flexibility in an energy-recovery loop layout. It is particularly attractive for a storage ring upgrade if the existing ring can be used as a beam turn-around path. However, a full-energy DERL will cost more to construct and operate. Technically, longitudinal phasing accuracy could be a challenge, though it may be easier to handle in a DERL due to separate access to accelerating and decelerating beam paths.

FEASIBILITY OF A DUAL-AXIS CAVITY

In this section, we give a conceptual design for a single-cell dual-axis cavity in order to illustrate the DERL concept and to examine the feasibility of the accelerating mode. Engineering design of a dual-axis cavity requires future R&D to address multipacting, HOM/LOM damping, microphonics, wakefield effects, and so on. The preliminary goal of our conceptual design is to show that it is possible to create a dual-axis cavity with an accelerating mode good for both beams and with reasonable basic rf parameters.

Guided by the simple idea to morph the TM_{21} (TM_{11}) mode in a rectangular (circular) waveguide to a geometry such that the field near the two axes resembles the commonly used accelerating mode (TM_{01} of circular cavity), we generated the conceptual design of an L-band dual-axis cavity, shown in Fig. 1. The circular contour and the flat sides are due to symmetry consideration. The field pattern

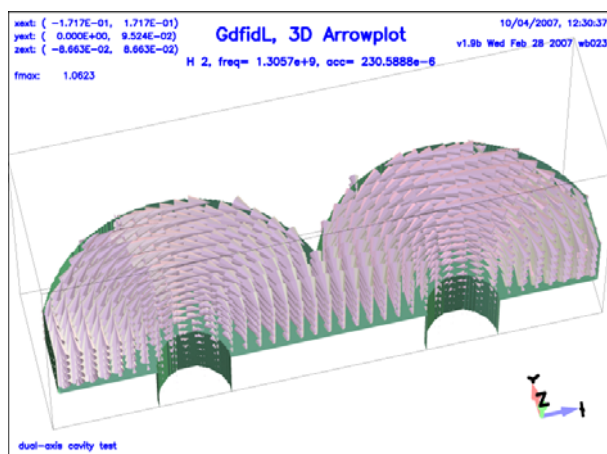

Fig. 4: Magnetic field of the accelerating eigenmode shown in Fig. 1.

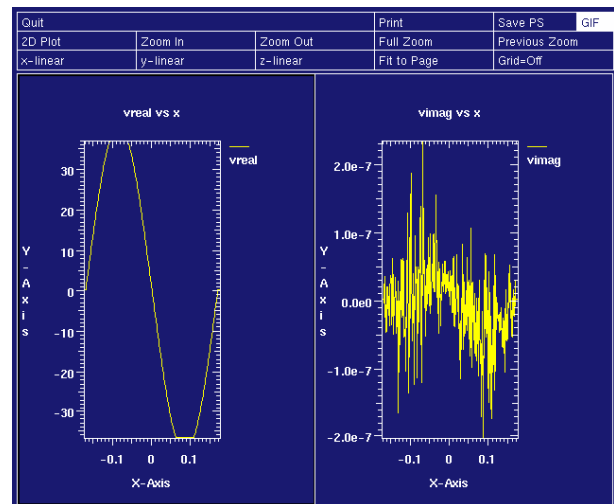

Fig. 5: Integrated accelerating voltage across the cavity. Note the flat tops within beam pipes which are desired for beam acceleration.

in Fig. 1 is the electric field of the accelerating eigenmode. It resembles two separate pillbox cavities, yet the two side cells are strongly coupled through the magnetic field component of the eigenmode shown in Fig. 4. A critical requirement for the accelerating mode is the uniformity of the integrated voltage gain across the beam pipes, which is important for preserving the beam energy spread, as well as for minimizing nonlinear transverse forces. Figure 5 shows the integrated voltage gain across the cavity and Fig. 6 shows the contour plot of the voltage gain. It shows that, despite certain distortions far from the beam pipe, the field within the beam pipes is rather axisymmetric and resembles the commonly used TM_{01} accelerating mode. The uniformity of the integrated voltage gain is rather good without much optimization effort.

The cavity geometry is given by: 8.3 cm cell length, 9.0 cm cell radius, 4.5 cm beam pipe diameter, 16.7 cm

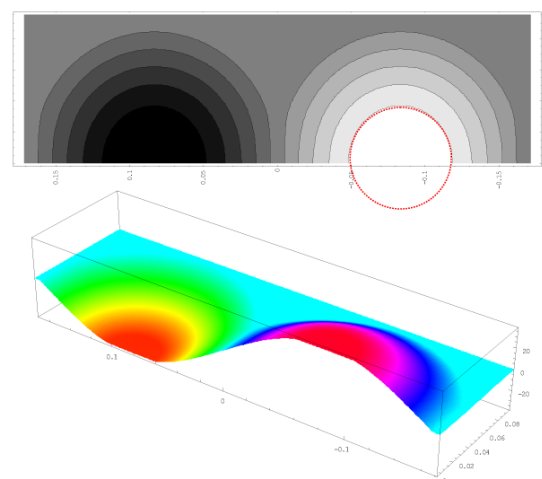

Fig. 6: Contour plot of the integrated accelerating voltage.

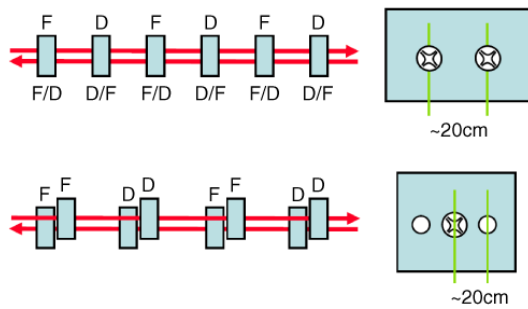

Fig. 7: Conceptual optics layout with dual-axis quadrupoles.

separation of the two beam axes. The basic rf parameters for the accelerating mode are: 1.3 GHz mode frequency, $Q_0 = 2.6 \times 10^3$ for room-temperature copper and about 2×10^{10} for 2K Niobium. R/Q is 89Ω for the cell. These numbers are fairly reasonable despite being only preliminary effort. There is a low-order mode about 70 MHz below and the lowest HOM is over 500 MHz above. Though preliminary, these results indicate the feasibility of the accelerating mode and call for further R&D.

FEASIBILITY OF DERL OPTICS

The distance between the two axes of the proposed dual-axis ERL will be smaller than the typical dimension of the normal quadrupoles needed for the beam optics. Thus, special quadrupoles with dual axes have to be used. Here we discuss the feasibility of such quadrupoles and conclude that there should be no problem at all. A conceptual FODO optics with dual-axis quadrupoles is shown in Fig. 7. Two types of dual-axis quadrupoles can be used. One has symmetric focusing/defocusing fields on both axes, as shown in the top part of Fig. 7. The other is much like a normal quadrupole, but with a field-free region for the second beam path as shown in the bottom part of Fig. 7. Both types of quadrupoles have been developed for the high-energy hadron colliders.

The best known dual-axis quadrupoles are probably those twin-aperture quadrupoles [8, 9] used in the LHC at CERN. Both normal conducting and superconducting quadrupoles have been built with field gradient and linearity better than an ERL may need. For a normal quadrupole with field-free beam pass, there is an interesting superconducting quadrupole design proposed for crab cavity optics [10], in which there is a natural field-free region for passing a beam through the quadrupole. Therefore, it is safe to say that dual-axis quadrupoles for a DERL are clearly feasible.

A speculative but interesting thought on superconducting magnets is to use high-temperature superconductor (HTS) like BSCCO-2223 tape instead of a metal superconductor like NbTi or Nb₃Sn [11]. At liquid hydrogen/helium temperatures, unlike NbTi/Nb₃Sn, even in the presence of very high magnetic field, HTS can still have a rather high critical current density, which makes it possible to build higher

gradient or more compact superconducting quadrupoles. There is a natural synergy between superconducting accelerating structure and superconducting quadrupoles. It may be possible and more cost-effective to integrate compact superconducting quadrupoles into the cavity cryomodule.

CONCLUDING REMARKS

In summary, the proposed dual-axis energy-recovery linac has many advantages over the standard ERL. It provides the opportunity for better and/or cheaper energy-recovery linac technology for ERL-based applications, especially for major facilities such as envisioned high-brightness x-ray light sources. Preliminary examination of DERL feasibility shows no obvious barriers. The potential benefits of a DERL call for major R&D on the dual-axis cavity structure, which is key to DERL development.

We would like to thank I. Ben-zvi for pointing out [3]. Special thanks are due to K. Harkay for connecting the authors who were independently thinking about this new idea and for her support of pursuing it. The author C.-x. Wang would like to thank his colleague Y. Chae for helping him to get started with the GdFidL program, which was used for the conceptual cavity design.

REFERENCES

- [1] A.M. Sessler and S.S. Yu, Phys. Rev. Lett. **58**, 2439 (1987).
- [2] Ya.S. Derbenev, Y.Y. Lau, and R.M. Gilgenbach, Phys. Rev. Lett. **72**, 3025 (1994).
- [3] D.W. Feldman et al., "The Los Alamos Free-Electron Laser Energy-Recovery Experiment," Proceedings of the 1987 Particle Accelerator Conference, p. 221 (1987).
- [4] C.-x. Wang, Phys. Rev. E **74**, 046502 (2006).
- [5] V.N. Litvinenko, R. Hajima, D. Kayran, Nucl. Instr. and Meth. **A557**, 165 (2006).
- [6] G.H. Hoffstaetter et al., "ERL upgrade of an existing x-ray facility: CHESS at CESR," Proceedings of the 2004 European Particle Conference, p. 497 (2004).
- [7] L. Assoufid et. al., "Advanced Photon Source Energy Recovery Linac Research and Development," APS whitepaper (2006).
- [8] R. Ostojic, "The LHC Insertion Magnets," IEEE Trans. Appl. Superconductivity, vol. 12, no 1, p. 196 (2002).
- [9] J. Strait, "Very high-gradient quadrupoles," Proceedings of the 2001 Particle Accelerator Conference, p. 176 (2001).
- [10] R. Gupta, "A quadrupole Design for crab cavity optics," LARP-doc-20-v1, (2005).
- [11] L. DelFrate et al., "Novel Muon Cooling Channels Using Hydrogen Refrigeration and High Temperature Superconductor," Proceedings of the 2005 Particle Accelerator Conference, p. 3126 (2005).