

DESIGN AND INITIAL RESULTS OF A HIGH CURRENT EBIS TEST STAND

J. Alessi, E. Beebe, A. Hershcovitch, A. Kponou, A. Pikin, K. Prelec, L. Snydstrup,
Brookhaven National Laboratory, Upton, NY 11973, USA

G. Kuznetsov

Budker Institute of Nuclear Physics, 630090, Novosibirsk, Russian Federation

Abstract

There is a program at Brookhaven National Laboratory to do the R&D required to design an Electron Beam Ion Source (EBIS) which could be used as part of a new, compact heavy ion injector for RHIC. This injector could serve as a replacement for the tandem, offering a wider range of ion species, more efficient operation (single-turn injection into the Booster), and lower operating costs. The program addresses issues relevant to the scaling of EBIS performance to RHIC requirements. The BNL effort is directed at reaching intensities of 3×10^9 particles/pulse of ions such as Au^{35+} and U^{45+} , and requires an electron beam on the order of 10A. On our existing EBIS, pulsed electron beams above 1A and ions such as Ti^{41+} have been produced. Much of our future research will move to a new test stand, now under construction. While the primary function of this test stand is the study of a 10A electron beam, it will be used to develop the technologies and study the physics relevant for a high intensity EBIS. The design and status of this EBIS, including the 10A electron gun and 1m long, 5T, warm bore superconducting solenoid, is described.

1 INTRODUCTION

The Relativistic Heavy Ion Collider (RHIC) at Brookhaven National Laboratory (BNL) is scheduled to be put into operation in the summer of 1999. Heavy ions will be provided by the existing MP-7 Tandem Van de Graaff accelerator, with beam parameters as required by RHIC. From the initial design through construction and commissioning of RHIC, the Tandem has been the only available option. However, it is possible to conceive of better options for future improvements; they are all based on a source producing ions in higher charge states, followed by a more efficient rf acceleration. There are a number of advantages that such a system might have: rf acceleration coupled with a higher charge state of ions is efficient and the system is simple and compact; such a system requires less maintenance and a smaller operating staff; a single turn injection into the Booster may be possible; a broad range in the choice of charge state of ions extracted from the source and a flexibility in selecting the optimum Booster injection energy permit an optimisation of the Booster performance;

and finally, the system would be located close to the Booster, eliminating a long transfer line.

The program at the BNL has as its objective the development of a heavy ion source of the EBIS type that would satisfy present and possible future requirements of RHIC. The first phase of this program was based on experiments with the Sandia National Laboratories' SuperEBIS, while for the second phase an electron beam test stand is being constructed to serve as a proof-of-principle device for the final EBIS for RHIC. During the first phase, experiments on the SuperEBIS, an electron beam current of 1 A has been achieved; narrow charge spectra of sodium (peak 7+), argon (peak 14+) and thallium (peak 41+) ions have been produced, at an electron beam neutralization degree above 50%. Encouraging results from these experiments have led to the decision to proceed with the design and construction of a new test stand, with the full electron beam power and 1/3 length of the EBIS for RHIC. This test stand will be used to develop technologies and study the physics aspects of a high intensity EBIS. We plan to address a number of issues, among them the technology of high current electron beam formation and launching, development of primary ion injection into the trap, the study of ion formation in and loss from a high current electron beam, and the study of fast ion extraction. A successful operation of this device will be followed by the design of the full scale EBIS, together with the rest of the injector.

2 PARAMETERS FOR AN EBIS MEETING RHIC REQUIREMENTS

The present scenario for acceleration of heavy ions from the Tandem starts with a 0.7 ms long pulse of Au^{32+} ions which are injected into the Booster over ~ 45 turns, accelerated, stripped to Au^{77+} (helium-like) and injected into the AGS. Four Booster pulses are stored in the AGS before the acceleration to the RHIC injection energy. The required number of ions in each RHIC bunch is 1×10^9 ; there are four bunches per AGS cycle transferred to RHIC. We have decided to follow a similar scenario for the injector using an EBIS; the corresponding ion beam intensity from the source is then 3×10^9 ppp for Au^{35+} and 2×10^9 ppp for U^{45+} . Ions would be extracted in a ~ 10 μs pulse, for single turn injection into the Booster.

Results of our experiments with the SuperEBIS [1] as well as those obtained elsewhere [2] have shown that it is

possible to obtain up to 20% of extracted ions in the desired charge state. Electron beam neutralization efficiencies above 50% have also been achieved. Assuming a trap length of 1.5 m (50% longer than SuperEBIS), it follows that we need an electron beam current of 10 A at a voltage of 20 kV. To produce U^{45+} ions during a confinement time not longer than 100 ms, the electron beam current density should be about 600 A/cm^2 .

3 TEST STAND ELEMENTS AND STATUS

As an intermediate step we are now building a test stand having an electron beam meeting the RHIC requirements, but with a 1/3 length (50 cm) trap region, where we could achieve 1/3 the ion yield required for RHIC. Fig.1 shows the simplified assembly drawing of this test stand. Its main components are a solenoid, electron gun, a system of insulated drift tubes, electron collector, gas and ion injection systems, a system of room temperature correcting coils to optimise the shape of the magnetic field, and ion beam diagnostics.

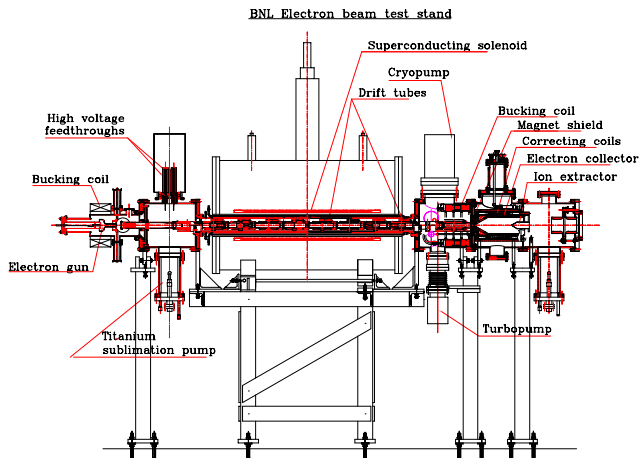

Figure 1: Layout of the electron beam test stand.

3.1 Solenoid

For electron beam focusing and confinement in the ion trap region we have decided to use an unshielded superconducting solenoid with a maximum field of 5 T; a warm bore has been chosen to enable a fast turnaround demanded by the experiments. The magnet is oriented horizontally to facilitate a matching to elements for beam diagnostics and eventual transport to accelerating stages. The solenoid, fabricated by Oxford Instruments, Inc., was delivered and installed at BNL. Axial field distribution and transverse deviations of the magnetic axis (which are within a cylinder with a radius of 0.2 mm) are fully satisfactory for our needs. In the process of acceptance tests at BNL the evaporation rates of LHe and LN have been measured; the values are 0.135 l/hour for LHe and 0.31 l/hour for LN. The rate of the magnetic field decay in the persistent mode is in 2.1 parts in 10^6 per hour. The magnet also passed several induced quenches.

3.2 Electron Gun

The electron beam current required to reach ion beam yields for RHIC is about 10 A, which is an order of magnitude higher than achieved in any existing EBIS. The design of the electron gun is of crucial importance not only because of such a high current but also because of the need for a flexible control of the electron beam parameters in an experimental device. After performing an extensive study of different electron gun geometries it was decided to adopt a coaxial diode with magnetic insulation, positioned in the field of a separate solenoid (Fig. 2.). The spherical convex LaB_6 cathode has a radius of curvature of 10.6 mm and transverse diameter of 8.3 mm. Fig. 3 shows the result of the electron gun optics simulation, for a current of 13.6 A.

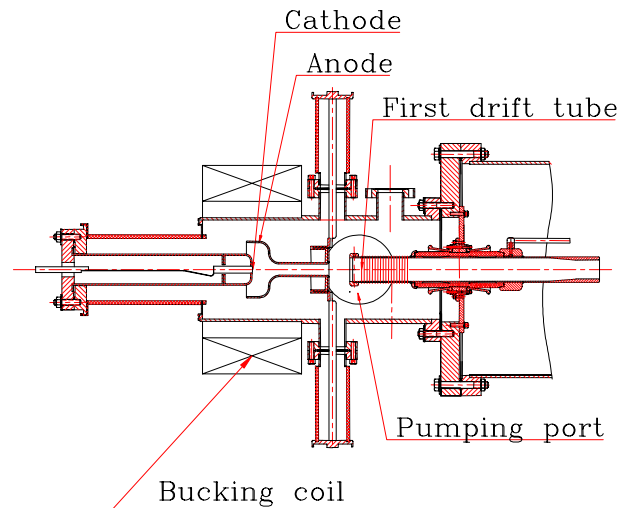

Figure 2: Schematic of the 10 A electron gun.

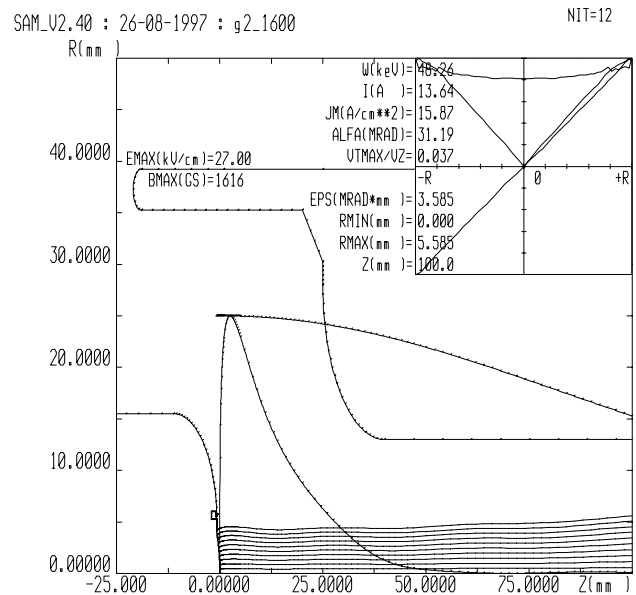

Figure 3: Electron gun optics simulation.

The gun has been designed and fabricated at the Budker Institute of Nuclear Physics, Novosibirsk; it was tested with 12 μ s current pulses of 22 A (pulse width limited by target power handling). The gun is presently mounted on a test bench in our laboratory, where testing will soon begin.

3.3 Drift Tube System

The drift tube system consists of 12 cylindrical electrodes, but only the four central tubes form the trap itself, located in the region of uniform axial field. The average length of the tubes is 15 cm, and the inner diameter is 3.2 cm. The selected value for this inner diameter is a compromise between two contradictory requirements: a shallow potential well to avoid virtual cathode formation, and low ion losses from the trap. The axial potential in the trap region with the full electron beam may be as low as 10 kV, with the anode voltage of 50 kV. Prototypes of drift tubes have been fabricated and high voltage tested.

3.4 Electron Collector

The electron collector is a critical element of an EBIS. There are two effects related to the collector that will affect the operation of the device: reflection of primary electrons from the region in front of the collector surface and their penetration into the trap region, and outgassing of the collector surface under bombardment by primary electrons. Both effects may lead to plasma instabilities in the electron beam or high frequency field oscillations in the structure itself. The shape of the collector has been determined after an extended study of the electron optics. The average heat load on the collector will be 50 kW; water will be used for cooling. The collector has been fabricated and is in the process of assembly with built-in bucking and transverse correction coils.

3.5 Vacuum

The vacuum system of the test stand has to provide a pressure of residual gas of $< 1 \times 10^{-10}$ Torr in the trap region under normal operating conditions with a 10 A electron beam. All parts of the test stand have been baked before installation; components in the central part were vacuum fired. After each exposure to atmosphere components will again be baked, some of them at a temperature of 450°C. All vacuum chambers have been fabricated and are ready for the final assembly. The central chamber has achieved a vacuum of 4×10^{-11} Torr, after 5 hours baking at 200°C.

3.6 Ion Injection

The test stand will be provided with an ion injection system, containing two external ion sources mounted on different branches of a common chamber. Each line contains lenses and electrostatic deflectors for focusing and steering of the primary ion beam. There will be a gas

injection system for gaseous elements or for cooling gas injection. The chamber has been fabricated and tested.

3.7 Control System

Much of the control system for the Electron Beam Test Stand has been previously developed in our laboratory for operation of the Sandia/BNL TestEBIS. Most of the power supplies used for the electron and ion beam optics are controlled through graphical interfaces using Labview and Labwindows programs. An EBIS voltage controller has been developed to coordinate the application of all time dependent voltages and timing references, with a time resolution of 1 μ s. Fast pulsing of the electron beam during early testing will be accomplished by using 65 kV high voltage switches to control the electron gun anode. The drift tube supplies will be comprised of 30 kV switches to accommodate rapid changes to the axial ion trap potential distribution necessary to produce short ($\sim 10 \mu$ s) extracted ion pulses.

The high power electron beam of the test stand presents the possibility of both vacuum degradation and serious mechanical damage. A redundant software and hardware system will be developed to monitor vacuum pressure, electron beam current losses, and temperatures. The electron beam will be interlocked with respect to excursions of these parameters. The software thresholds would be set mainly to guard against vacuum degradation; hardware thresholds will prevent serious mechanical damage.

4 SCHEDULE

The test stand is presently in its final assembly stage. First electron beam tests are scheduled for late summer 1998, with ion production experiments to follow.

ACKNOWLEDGMENTS

We would like to thank Steve Bellavia, Dave Boeje, Walter Hensel, Bob Lockey, Dan McCafferty, Wally Shaffer, Paul Stein, and Werner Tramm for their ongoing assistance on this project. The electron gun simulation work of M. Tiunov is gratefully acknowledged.

REFERENCES

- [1] E. Beebe, J. Alessi, A. Hershcovitch, A. Kponou, A. Pikin, K. Prelec, P. Stein, and R.W. Schmieder, *Rev. Sci. Instrum.* **69**, 640 (1998).
- [2] L. Liljeby (private communication, February 1995).
- [3] A. Kponou, E. Beebe, A. Pikin, G. Kuznetsov, M. Batazova, and M. Tiunov, *Rev.Sci.Instrum.* **69**, 1120 (1998).