

R&D ACTIVITIES AIMED AT DEVELOPING A CURVED FAST RAMPED SUPERCONDUCTING DIPOLE FOR FAIR SIS300

**P.Fabbricatore¹, F. Alessandria², G. Bellomo², S. Farinon¹, U. Gambardella³,
J.Kaugerts⁴, R.Marabotto⁵, H.Müller⁴, R.Musenich¹, G.Moritz⁴, D. Pergolesi¹,
M.Sorbi² and G. Volpini²**

(1) INFN-Genova, Italy

(2) INFN-LASA and Milan University, Physics Department, Italy

(3) INFN-Laboratori di Frascati, Italy

(4) GSI-FAIR, Germany

(5) ASG-Superconductors (former Ansaldo), Genova, Italy,

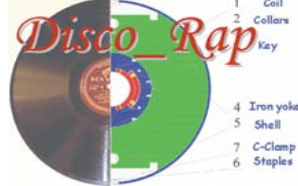

R&D ACTIVITIES AIMED AT DEVELOPING A CURVED FAST RAMPED SUPERCONDUCTING DIPOLE FOR FAIR SIS300

P.Fabbricatore INFN-Genova

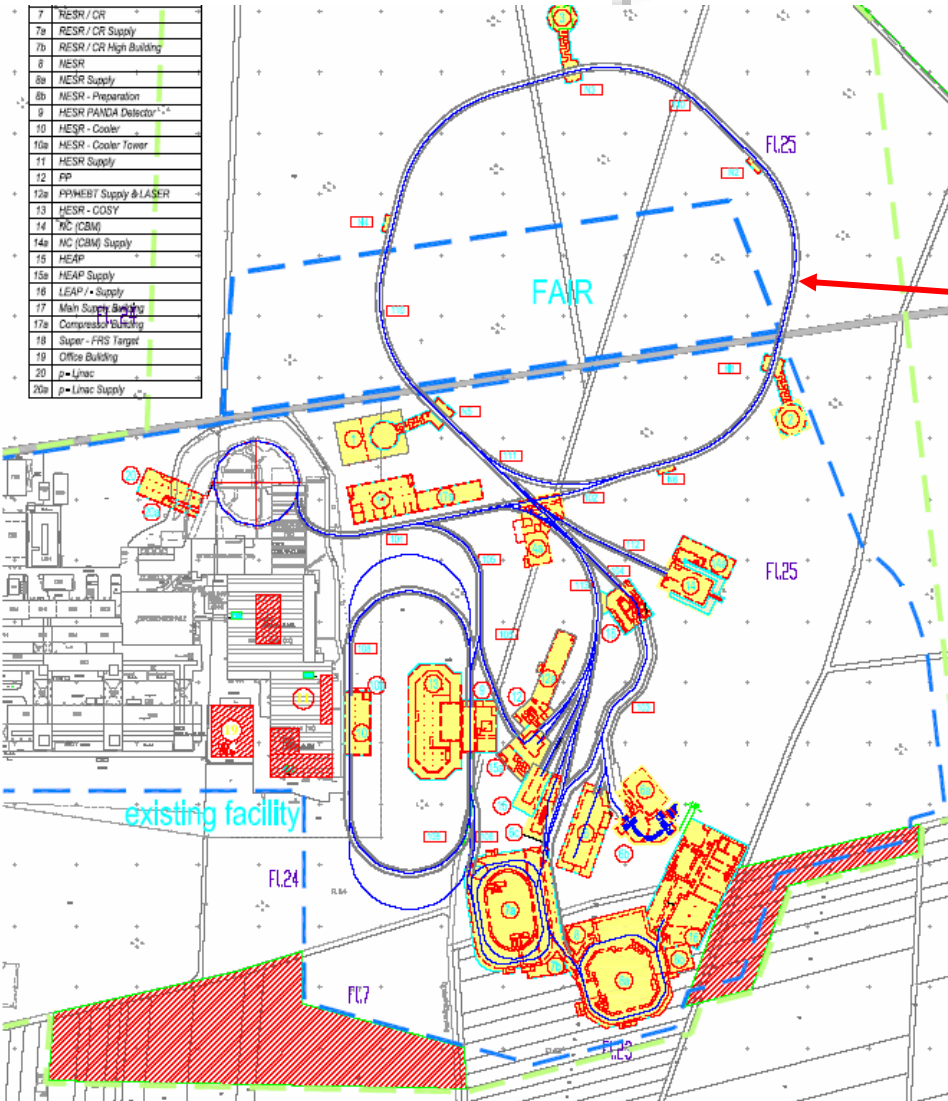

The facility **FAIR** including the synchrotrons

SIS100 and SIS300

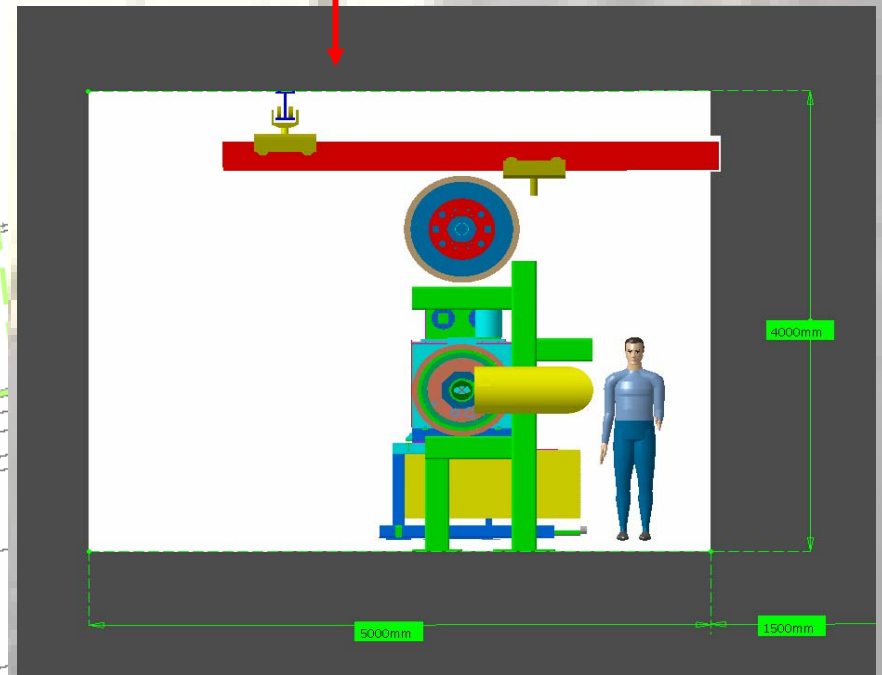

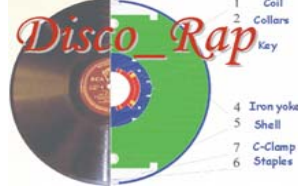

48 long dipoles – Magnetic length 7.89 m
12 short dipoles – Magnetic length 3.94 m

SIS 300 arc cryostat stacked on top of SIS 100

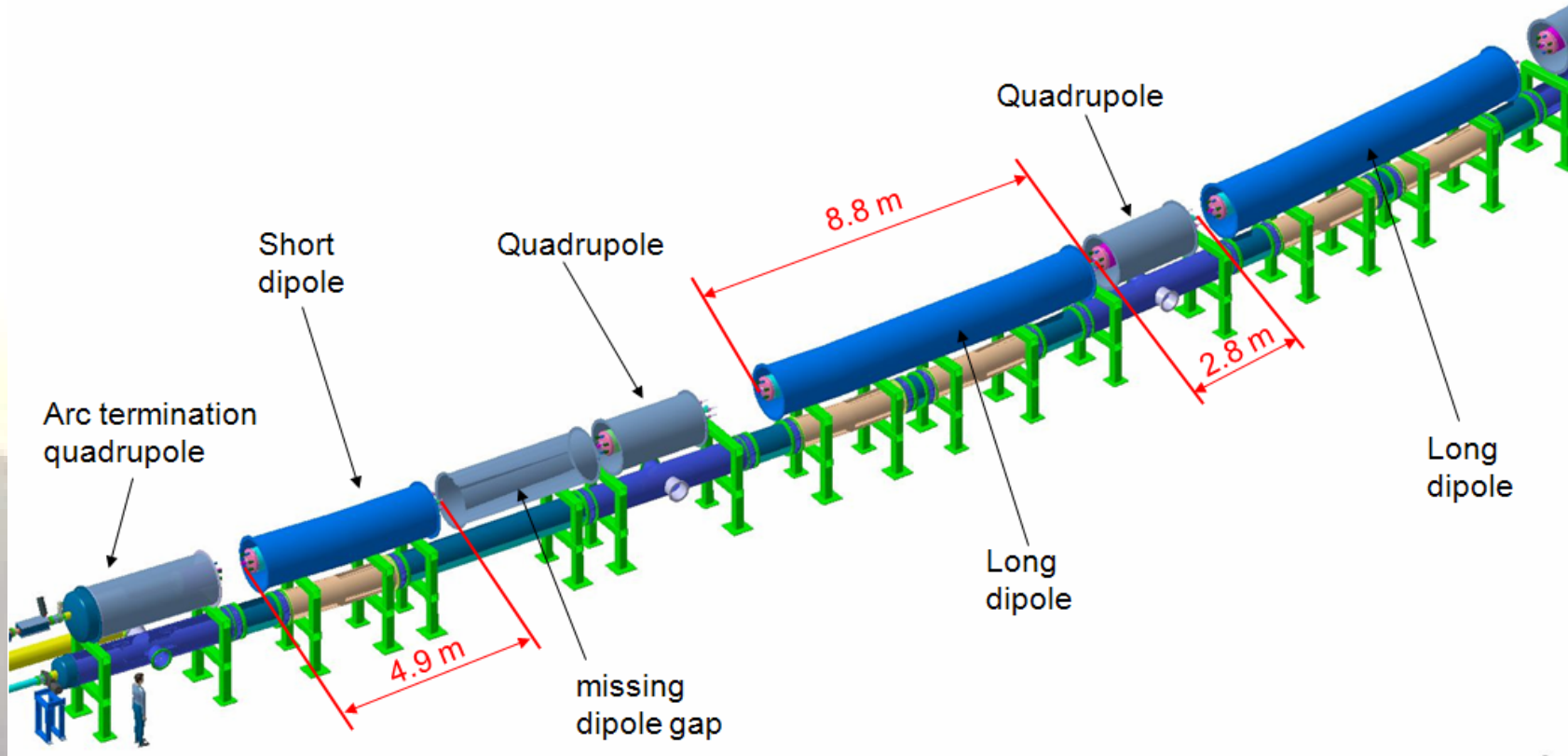

We are working at the development of a design for these magnets. The achievement of this target is passing through a R&D activity (**DiSCo_RaP**) aimed to the construction of a **model of the short dipole**.

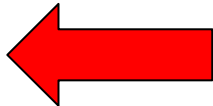
Nominal field	4.5 T
Ramp rate	1.0 T/s 
Radius of curvature	66.67 m
Magnetic length	3.784 m
Bending angle	3 1/3 deg.
Coil aperture diameter	100 mm
Max operating temperature of LHe	4.7 K
Current sharing temperature	5.7 K
Operating conditions (fraction of I_c on the load line)	69%
Field quality at radius $R=35$ mm	2 (in 10^{-4} units)

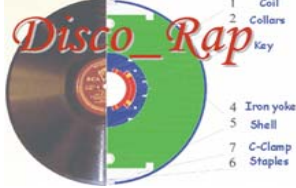

Criticities of SIS300 dipoles → Demand for R&D

- 1) AC losses**
- 2) Field quality**
- 3) Manufacturing**
- 4) Large number of magnetic cycles**

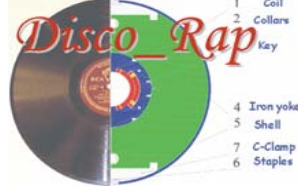

1) AC losses

Ac losses in the superconducting cable

- 1.1) Hysteretic losses in the superconductor
- 1.2) Coupling losses in the strand multifilamentary structure
- 1.3) Losses due to coupling currents between strands

Losses in the iron (Irreversible Magnetization, Eddy currents)

Eddy currents in the metallic structure

The heat generated shall be removed by the cooling system. We can have two unwanted cases:

- 1) Due to the limited heat transfer capability of cooling system the coil could quench
- 2) The thermal load to cooling system is high → High operation costs

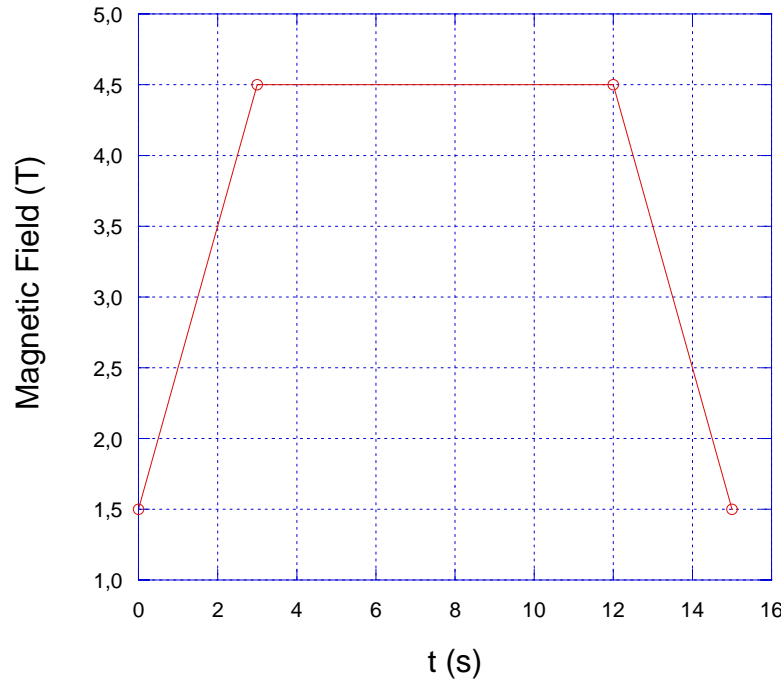
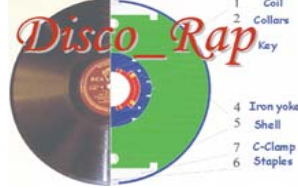

	Aperture (mm)	B (T)	dB/dt (T/s)	Q (W/m)
LHC	53	8.34	0.0075	0.18
RHIC	80	3.5	0.07	0.35
SIS300	100	4.5	1	<10

- Development of a low loss superconducting cable
- Maximization of the heat flow to the coolant
- Minimization of eddy currents





Contribution to ac losses (ramping) 34.4 W (9 W/m)

Hysteresis	36.5 %
Coupling Strand	10.7 %
Interstrand Ra+Rc	5.9 %
Total conductor	(53.1 %)
Collars + Yoke eddy	4.0 %
Yoke magn	16.2 %
Beam pipe	12.2 %
Collar-Keys-Pins	8.7 %
Yoke-Keys-Pins	5.8 %

Ac losses in the superconducting cable: a summary of conductor requirement and critical R&D

- 1) Hysteretic losses in the superconductor

$$Q \propto a B_e J_c$$



Critical R&D for reducing filament dimensions (3.5 - 2.5 μm)

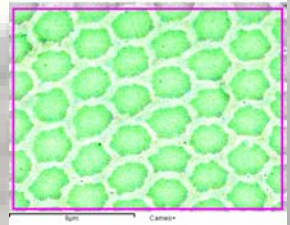

- 2) Coupling losses in the strand multifilamentary structure

$$Q_e \propto \frac{B_{e \text{ peak}}^2}{\rho_{et}} \frac{l_p^2}{T}$$



Critical R&D for optimizing interfilament resistivity and minimizing twist pitch

- 3) Coupling losses between strands

$$Q_c \propto \frac{B_{e \text{ peak}}^2}{R_c} \frac{l_{pRuth.}}{T}$$

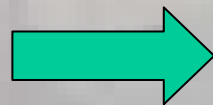

Critical R&D for reducing/optimizing crossover interstand resistance and adjacent resistance. Minimize twist pitch

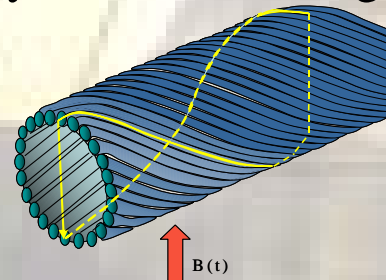

$$Q_a \propto \frac{B_{e \text{ peak}}^2}{R_a} \frac{l_{pRuth.}}{T}$$

Ac losses in the superconducting cable: a summary of conductor requirement and critical R&D

- 1) Hysteretic losses in the superconductor

$$Q \propto a B_e J_c$$



Critical R&D for reducing filament dimensions (3.5 - 2.5 μm)

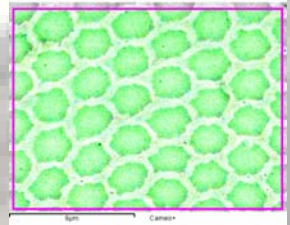

- 2) Coupling losses in the strand multifilamentary structure

$$Q_e \propto \frac{B_{e \text{ peak}}^2}{\rho_{et}} \frac{l_p^2}{T}$$



Critical R&D for optimizing interfilament resistivity and minimizing twist pitch

- 3) Coupling losses between strands

$$Q_c \propto \frac{B_{e \text{ peak}}^2}{R_c} \frac{l_{pRuth.}}{T}$$

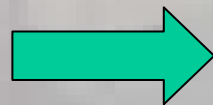

Critical R&D for reducing/optimizing crossover interstrand resistance and adjacent resistance. Minimize twist pitch

$$Q_a \propto \frac{B_{e \text{ peak}}^2}{R_a} \frac{l_{pRuth.}}{T}$$

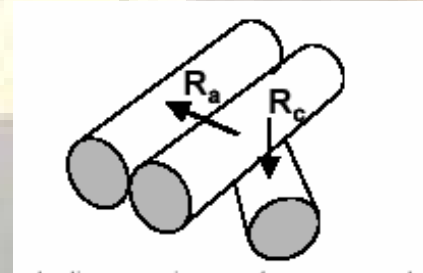

Ac losses in the superconducting cable: a summary of conductor requirement and critical R&D

- 1) Hysteretic losses in the superconductor

$$Q \propto a B_e J_c$$



Critical R&D for reducing filament dimensions (3.5 - 2.5 μm)

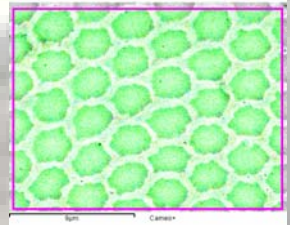

- 2) Coupling losses in the strand multifilamentary structure

$$Q_e \propto \frac{B_{e \text{ peak}}^2}{\rho_{et}} \frac{l_p^2}{T}$$



Critical R&D for optimizing interfilament resistivity and minimizing twist pitch

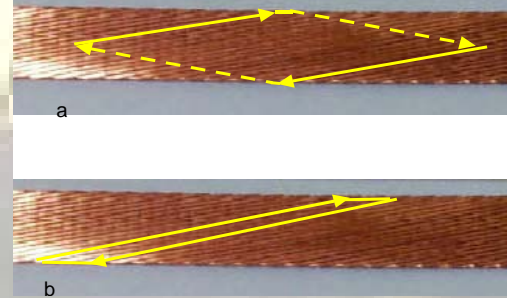

- 3) Coupling losses between strands

$$Q_c \propto \frac{B_{e \text{ peak}}^2}{R_c} \frac{l_{pRuth.}}{T}$$

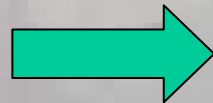

Critical R&D for reducing/optimizing crossover interstand resistance and adjacent resistance. Minimize twist pitch

$$Q_a \propto \frac{B_{e \text{ peak}}^2}{R_a} \frac{l_{pRuth.}}{T}$$

Conductor under construction at Luvata Fornaci di Barga

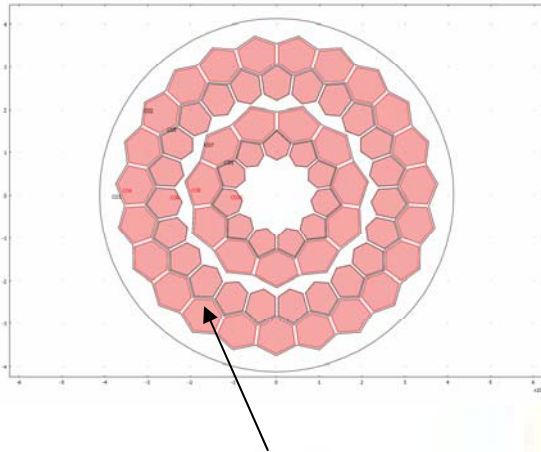

30 to 40 thous. NbTi
filaments in CuMn
matrix
 $s/d \sim 0.15$

Wire		
Diameter after surface coating	0.825 ± 0.003	mm
Filament twist pitch	$5 + 0.5 - 0$	mm
Effective Filament Diameter for 1st Generation wire	3.5	μm
Effective Filament Diameter for 2nd Generation wire	2.5	μm
Interfilament matrix material	Cu-0.5 wt% Mn	
Filament twist direction	right handed screw (clockwise)	
I_c @ 5 T, 4.22 K	> 541	A
n-index @ 5 T, 4.22 K	> 30	
Stabilization matrix	Pure Cu	
Strand transverse resistivity at 4.22 K	$0.4 + 0.09 B [T]$	$n\Omega \cdot \text{m}$
Cu+CuMn:NbTi ratio (α ratio)	> 1.5	
α ratio tolerance	± 0.1	
Surface coating material	Staybrite (Sn-5 wt% Ag)	
Surface coating thickness d	0.5	μm

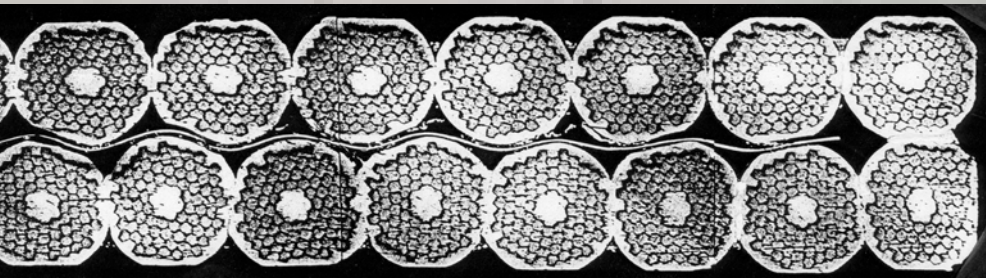

Cable made of 36 strands with a
core (thin sheath in SS 316L)

2) Field Quality

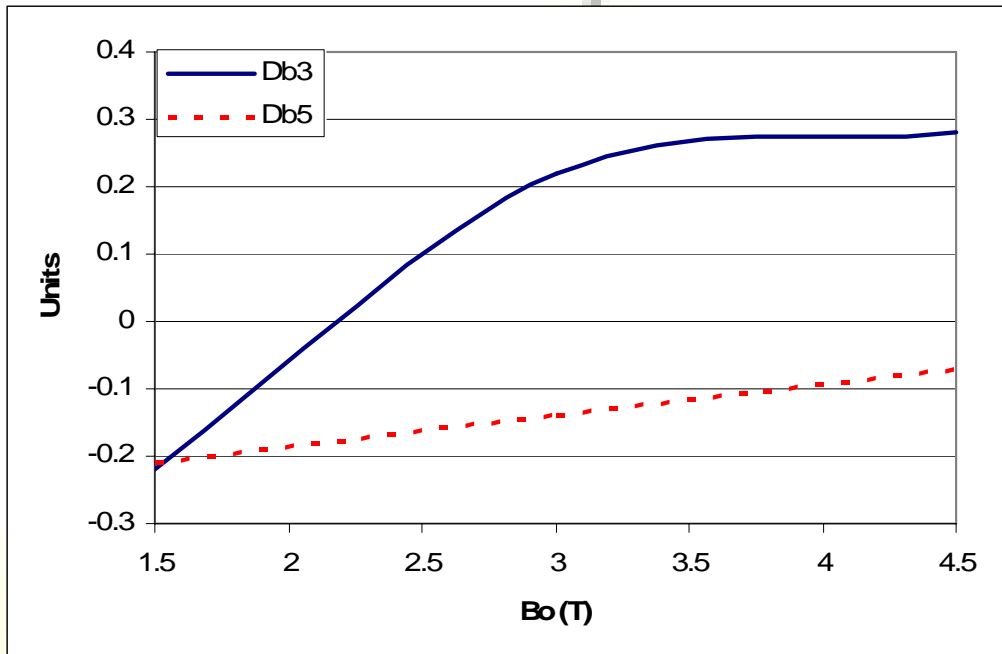

Total variation of sextupole and decapole field harmonics during the ramp up ($dB_0/dt=1$ T/s), due to persistent currents, eddy currents in conductor and paramagnetism of copper-manganese matrix

At present, the field quality seems under control from design point of view and looks much less critical than other aspects.

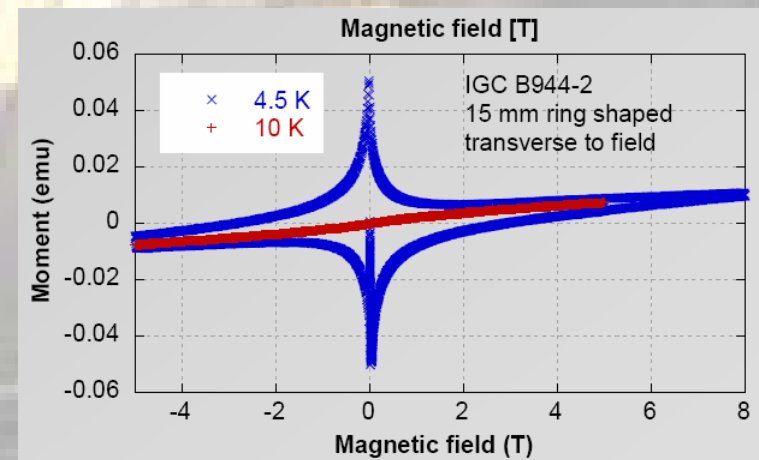

3) Manufacturing difficulties

The need of a low loss conductor imposes the use of a cored cable, stiffer than a simple Rutherford cable, so making the winding harder



We think that the coil should be wound curved . This solutions allows defining without uncertainty the geometrical dimensions of a curved stress-free coil (no spring back effects)

→ **Development of the winding technologies for curved poles with cored cable.** This activity is under progress in ASG-Superconductors. At present we have many evidences that a suitable manufacturing methodology can be obtained

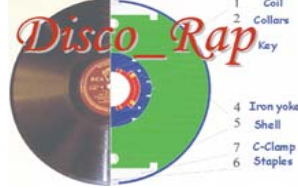

A special winding machine has been developed at ASG-Superconductors. Successful winding tests done first with with LHC outer layer conductor ...





**R&D ACTIVITIES AIMED AT DEVELOPING A
CURVED FAST RAMPED SUPERCONDUCTING
DIPOLE FOR FAIR SIS300**

P.Fabbricatore INFN-Genova





**R&D ACTIVITIES AIMED AT DEVELOPING A
CURVED FAST RAMPED SUPERCONDUCTING
DIPOLE FOR FAIR SIS300**
P.Fabbricatore INFN-Genova

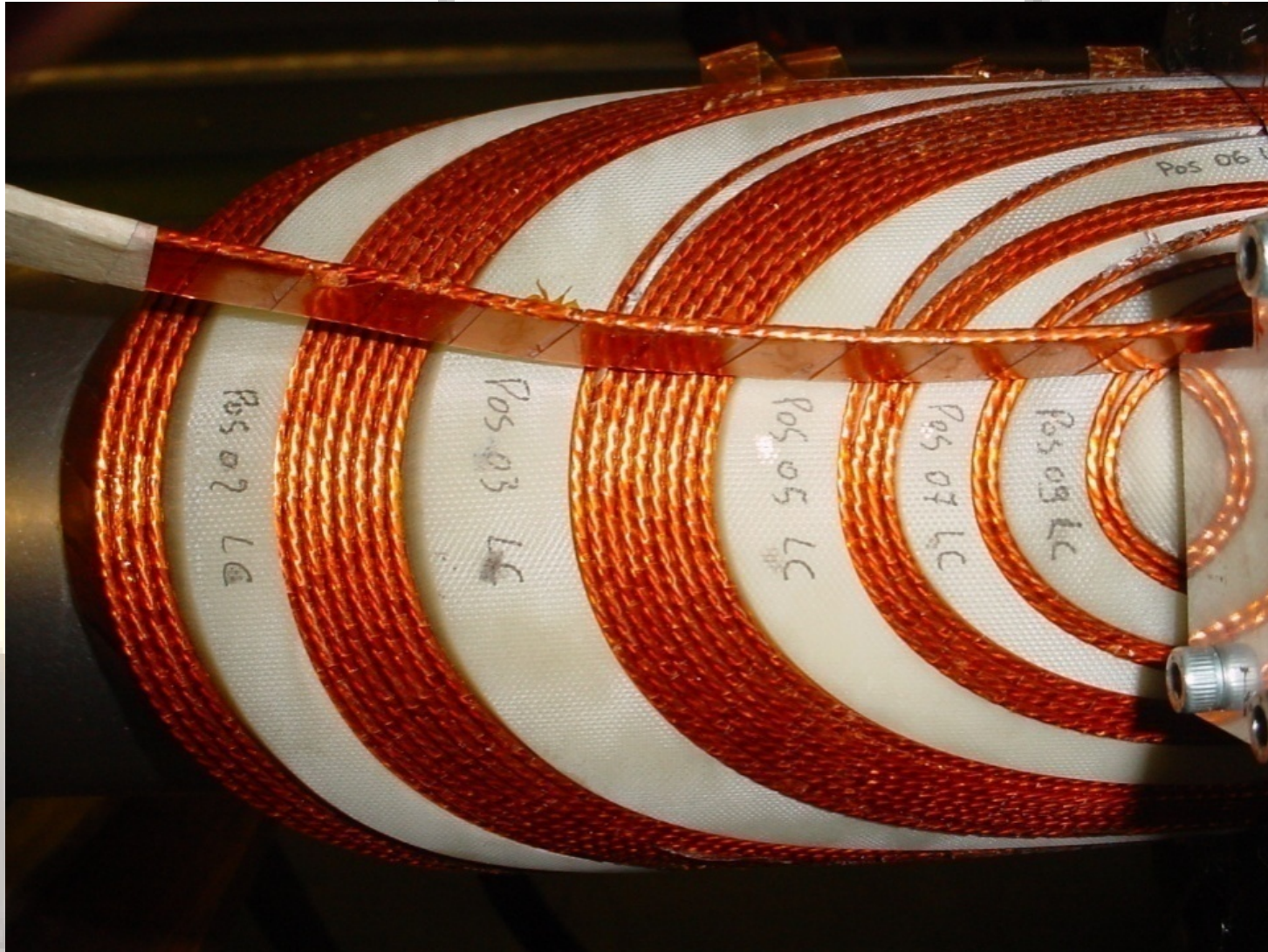

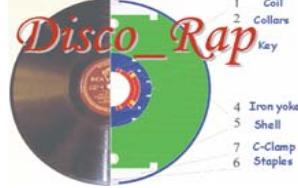

**R&D ACTIVITIES AIMED AT DEVELOPING A
CURVED FAST RAMPED SUPERCONDUCTING
DIPOLE FOR FAIR SIS300**

P.Fabbricatore INFN-Genova

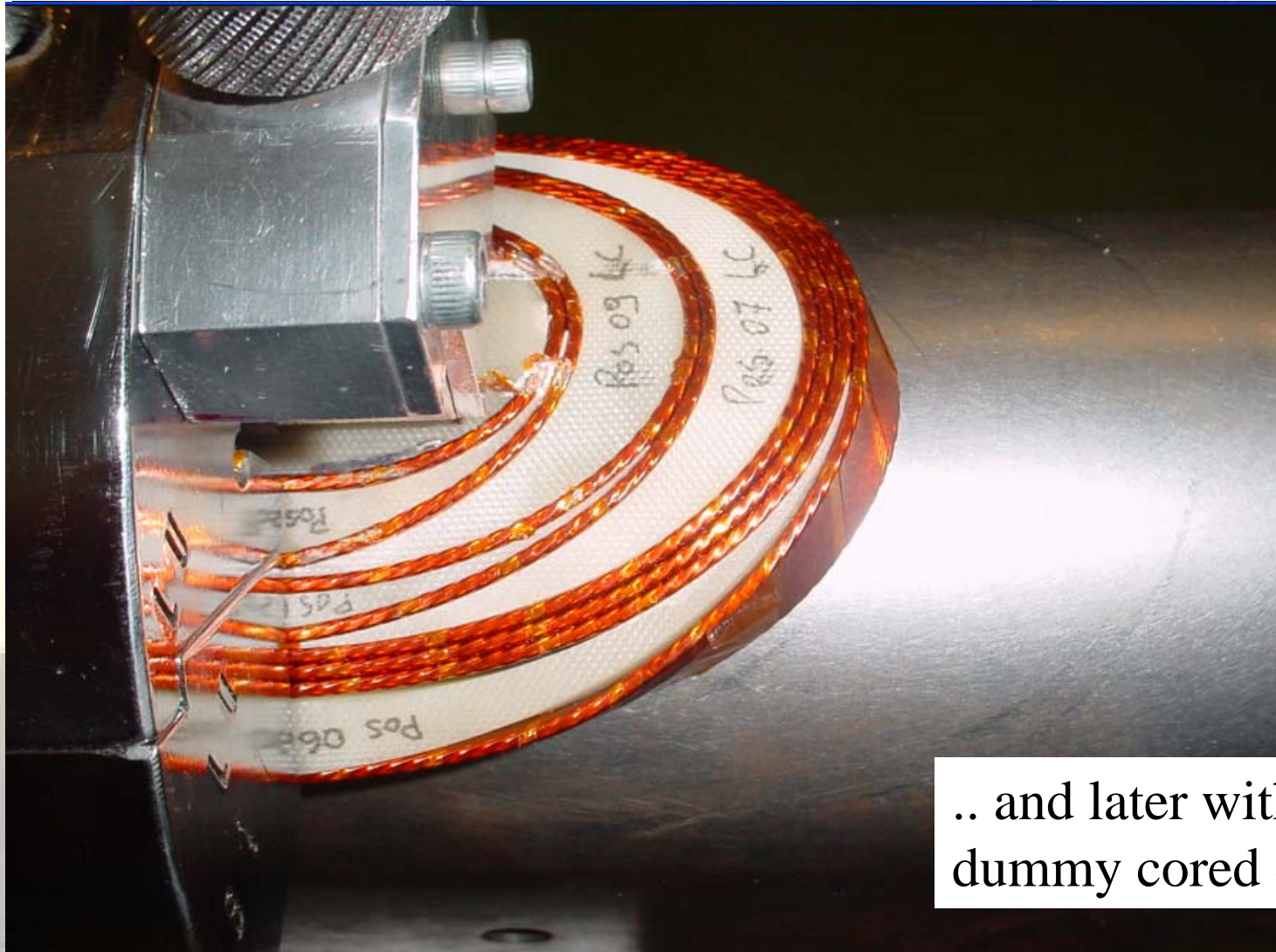

.. and later with a dummy cored conductor

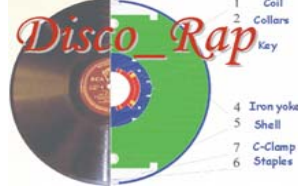

3) Fatigue load

The magnets shall be cycled 10 million times, consequently the design shall be optimised in view of severe fatigue loads. Radiation effects may even weaken the material with respect mechanical and electrical strength.

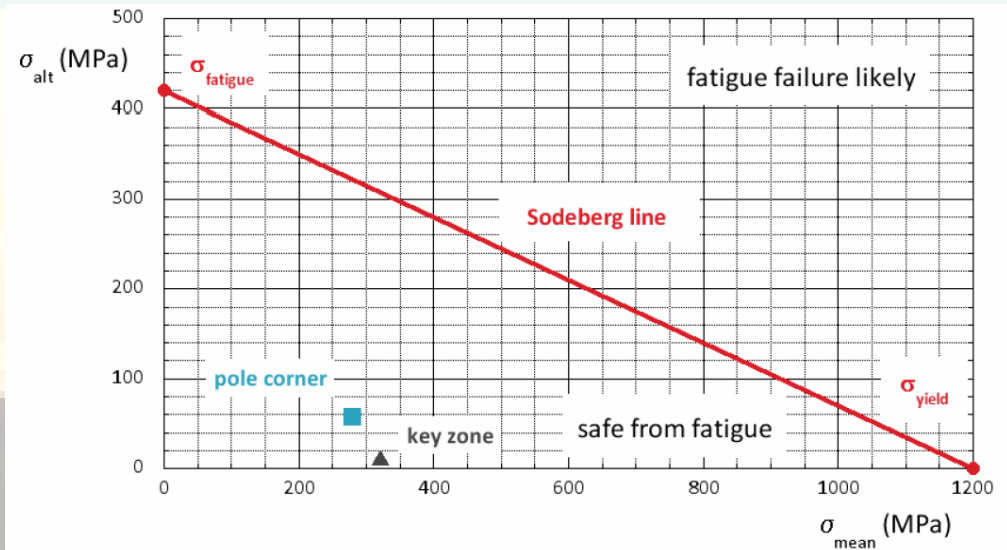
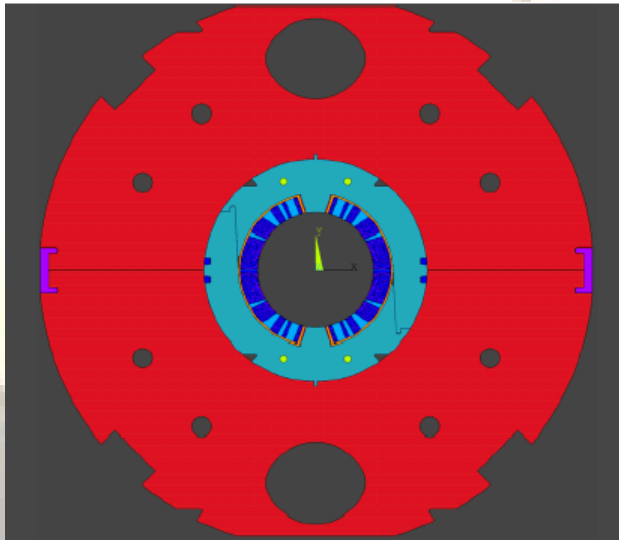

→ Mechanical design optimization to be checked through experimental results on the model

3) Fatigue load

The magnets shall be cycled 10 million times, consequently the design shall be optimised in view of severe fatigue loads. Radiation effects may even weaken the material with respect mechanical and electrical strength.

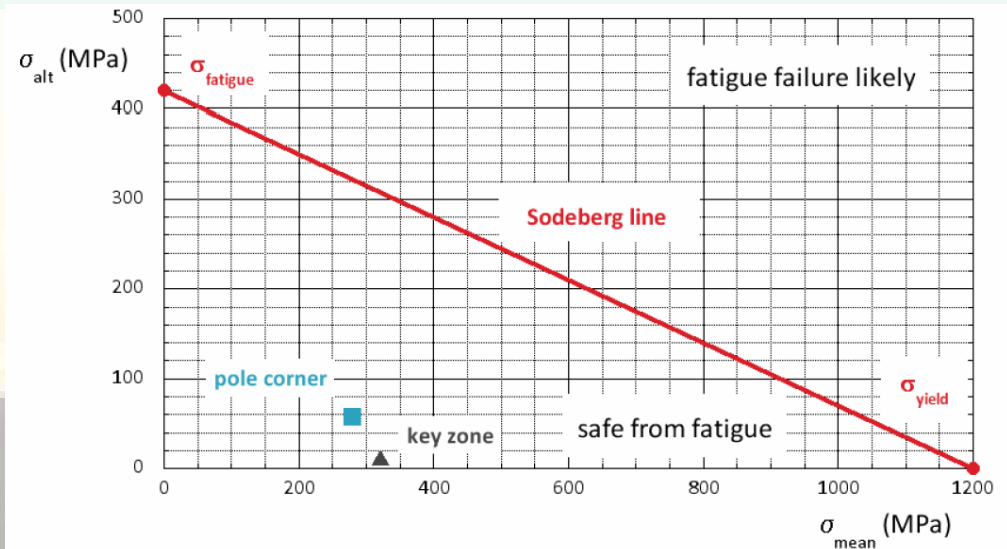
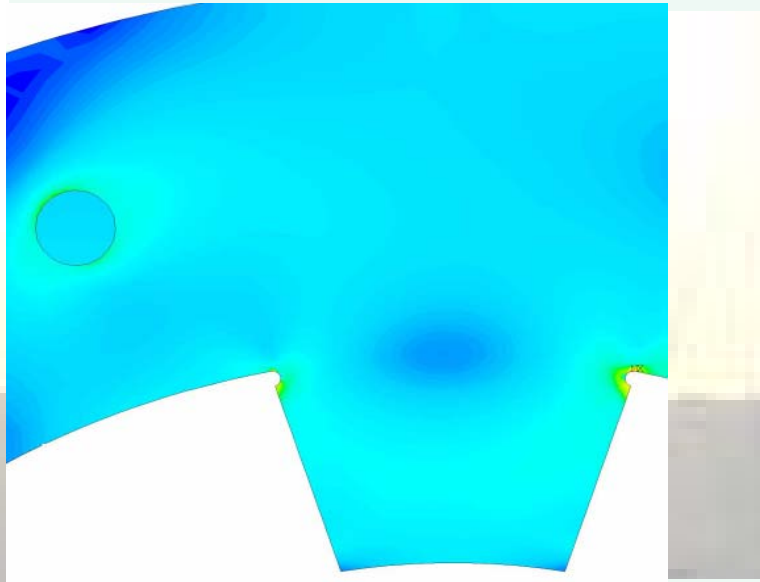

→ Mechanical design optimization to be checked through experimental results on the model

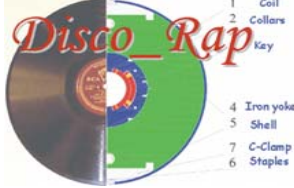

The design of the model is close to be finalised (Summer 2008)

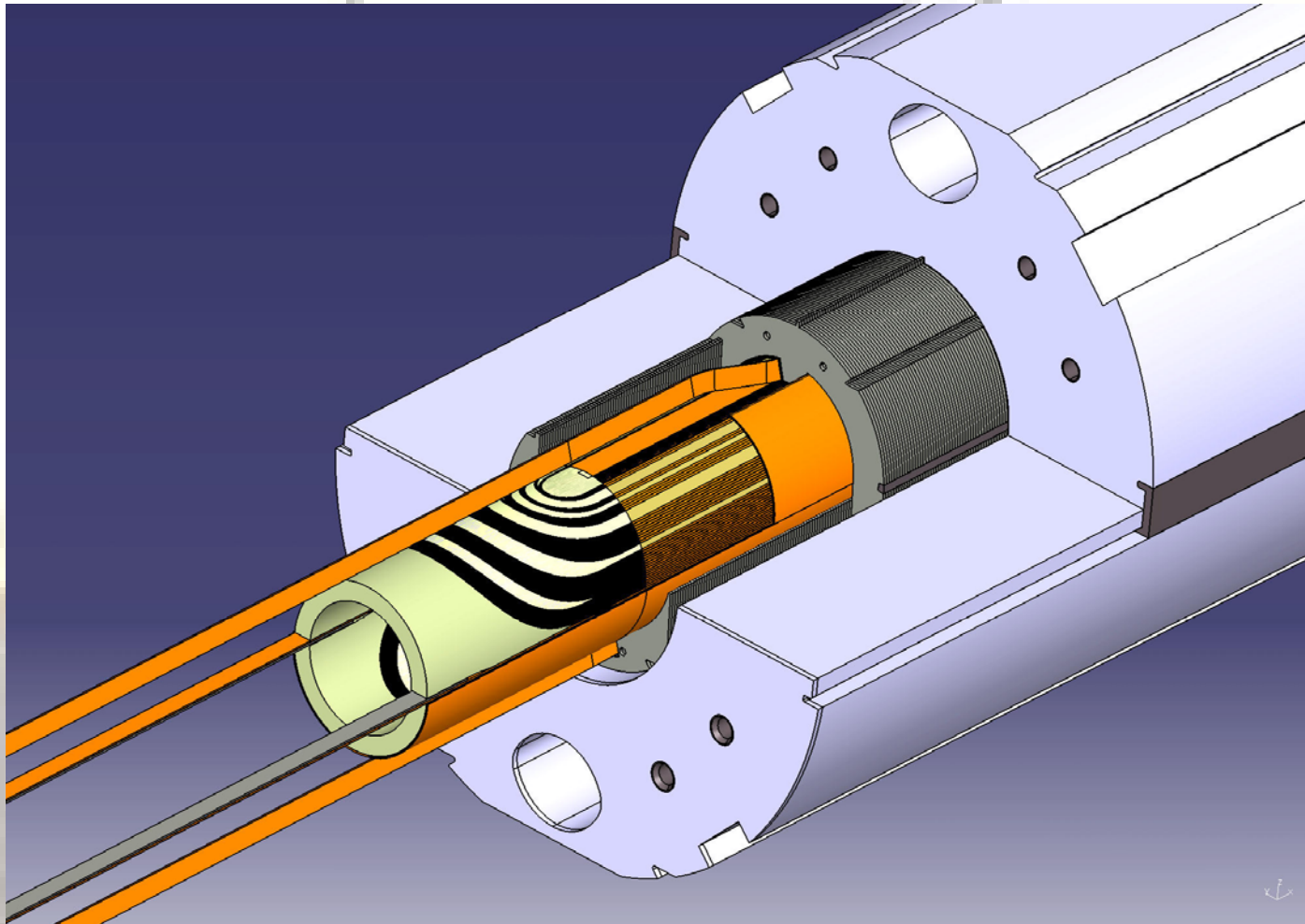



**R&D ACTIVITIES AIMED AT DEVELOPING A
CURVED FAST RAMPED SUPERCONDUCTING
DIPOLE FOR FAIR SIS300**
P.Fabbricatore INFN-Genova

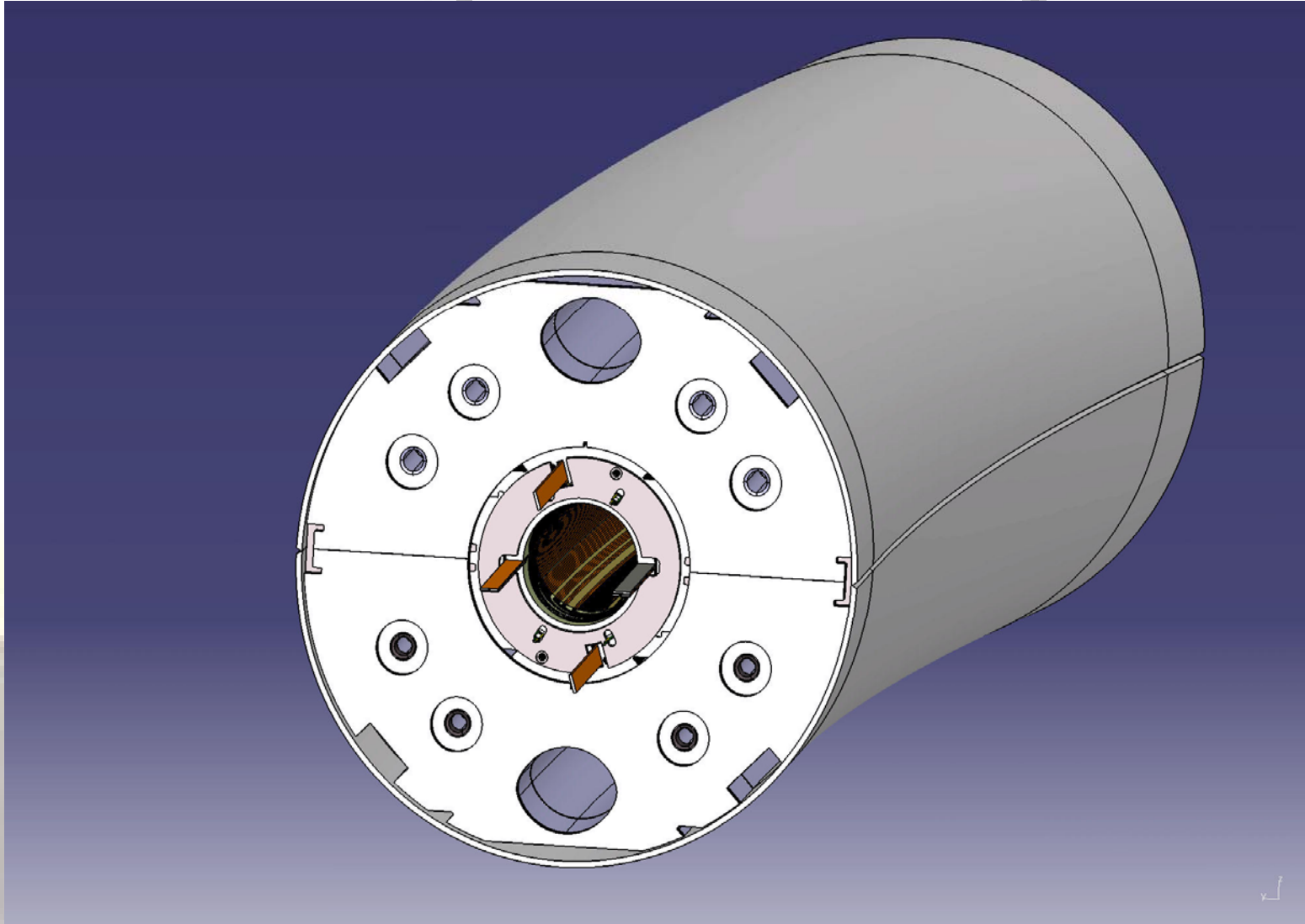

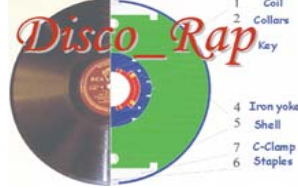

Conclusions

Low loss cable, heat removal, fatigue, methods for manufacturing a curved winding are the main problems we are facing with the R&D activity DiSCoRaP .

Design, winding test and conductor development are going on with the final target of a model coil in its horizontal cryostat ready by end of next year

A winding technology for curved poles with cored cable was developed.