

METALLIC PHOTONIC BAND GAP ACCELERATOR STRUCTURE EXPERIMENTS AND DESIGN*

Roark A. Marsh[†], Michael A. Shapiro, Richard J. Temkin,

Plasma Science and Fusion Center, Massachusetts Institute of Technology, Cambridge, MA 02139

Abstract

Damping wakefields is a critical issue in the next generation of high gradient accelerators. Photonic bandgap (PBG) structures have unique properties that offer significant wakefield damping. The goal of this work is to quantify the higher order mode (HOM) wakefield content of a constructed metallic PBG accelerator structure, in order to test the theory of wakefield excitation in these structures and to provide direction for future structure design. Experimental measurements of wakefields excited by an 18 MeV electron beam in a 6 cell, 17.14 GHz metallic PBG traveling wave accelerator structure are reported. Because the electron beam used to generate wakefields in the PBG structure is bunched at the 17.14 GHz rf frequency, all wakefields observed were at integer multiples of 17.14 GHz. Using diode detectors, radiation has been observed at the input and output coupler ports as well as through a quartz window in the surrounding vacuum vessel. Estimates of wakefield radiation, made using *HFSS* and basic wakefield theory, compare well with experiment.

INTRODUCTION

Wakefield damping is an important consideration in accelerator structure design. Photonic crystals are an appealing theoretical starting point for a damped structure. The frequency dependent properties of photonic crystals make it possible to form the confining wall of an accelerator structure such that a fundamental, operating mode is confined, but higher order modes (HOMs), which are of higher frequency are not. The use of a metallic photonic bandgap (PBG) structure as an accelerator was first proposed in [1], and designed with an analysis of actual wakefield damping and cavity performance in [2]. Such a structure has been built, cold-tested, tuned, and hot-tested, demonstrating an accelerating gradient of 35 MV/m, limited by available microwave power [3, 4].

After demonstrating acceleration, the wakefield damping parameters of the structure are of primary interest. The PBG structure, shown in Fig. 1 and Fig. 2 is made up of a triangular lattice of cylindrical rods, with a one rod defect; end plates are flat metallic plates with beam holes, or irises. Experiments are reported in this paper to directly observe wakefield radiation produced by passing an electron beam through the unpowered 6 cell structure, following preliminary results [5]. The wakefields are measured with diode

detectors and compared with simple beam structure coupling theory.

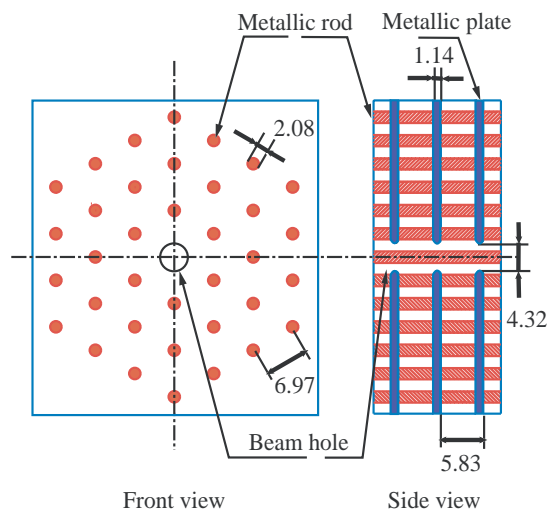

Figure 1: Schematic of the 6 cell PBG accelerator structure; dimensions are in mm

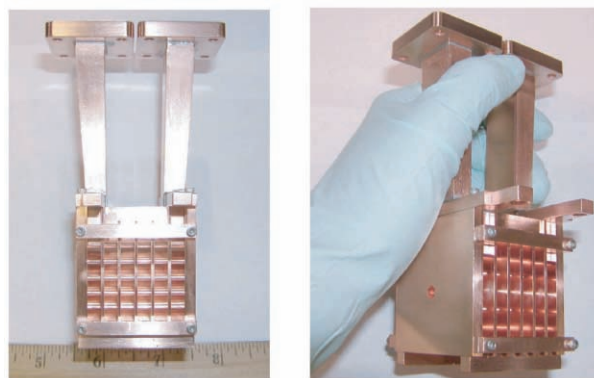

Figure 2: Photographs of the 6 cell metallic PBG traveling wave accelerator structure.

THEORY

Cold Test

The 6 cell traveling wave structure was connected to an Agilent E8363B Precision Network Analyzer (PNA). A direct measurement of the mode frequency, insertion loss, and group velocity are input into the following traveling wave excitation formalism so that power level predictions

* Work supported by DOE HEP, under contract DE-FG02-91ER40648

[†] roark@mit.edu

can be made. These measurements were carried out for the fundamental 17.14 GHz TM_{01} mode by measuring the direct S_{21} magnitude and phase for the mode as a function of frequency. Phase measurements, $d\phi/df$, were unit converted into group velocity, $v_g = d\omega/dk$. Measurements were as follows: $v_g = 0.0109c$, insertion loss = 1.04dB, and $Q = 4000$; compared with design parameters: $v_g = 0.013c$, insertion loss = 0.8dB, and $Q = 4200$.

Traveling Wave Theory

Based on the structure measurements made in cold test and simulations performed using *HFSS*, power estimations can be made using simple traveling wave theory as developed in [6, 7]. The voltage loss per unit length, I , can be calculated in terms of the mode frequency, ω , group velocity, v_g , and quality factor, Q : $I = \frac{\omega}{2v_g Q}$. The power radiated by the beam, P_b , is then a special case of beam loading in the absence of external rf power:

$$P_b = \frac{E_b^2}{2Ir} = \left(\frac{i^2 r}{2I}\right) (1 - e^{-IL})^2 \quad (1)$$

Where $r = 98 \text{ M}\Omega/\text{m}$ is the mode shunt impedance calculated using *HFSS*, $L = 29.15 \text{ mm}$ is the electrical length of the structure, i is the average beam current, and the beam induced electric field, E_b is rewritten in terms of the other parameters. For 100 mA beam current, 1.540 kW are expected on the output port of the structure.

EXPERIMENT

Experimental Setup

The bunch train used in these radiation experiments was created with the 17 GHz linac manufactured by Haimson Research Corporation and installed at MIT. The linac was operated to produce 18 MeV 1 ps bunches at a repetition rate of 17.14 GHz and an average current of 10–300 mA [8, 9, 10]. The bunched linac beam train was passed through the 6 cell PBG structure shown in Fig. 1 and 2, which is housed in a stainless vacuum vessel on the beam line, shown schematically in Fig. 3. A fused quartz window was installed on the bottom of the vacuum chamber housing the PBG structure, as labeled in Fig. 3, so that radiation could be observed leaking out of the open PBG structure. The input and output couplers, as labeled in Fig. 3, were mounted with vacuum windows so that observations could also be made of radiation coupling out of the structure via the input and output coupler ports. During these wakefield measurements, no microwave power was injected into the structure.

Two sets of diode detectors were used, at both Ku (12–18 GHz) and Ka (26–40 GHz) bands. They were calibrated using their respective power heads and meters. The horns, waveguide, adapters, attenuators and vacuum windows used were calibrated over their respective frequency ranges using the PNA.

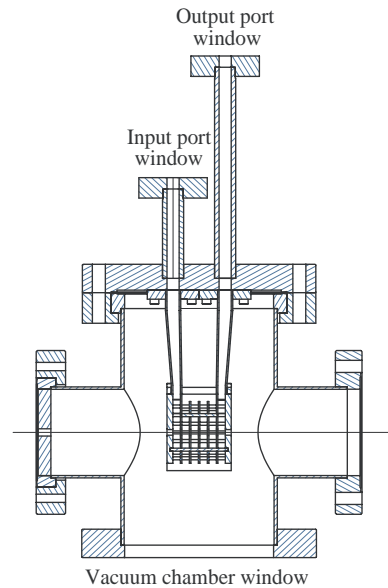

Figure 3: PBG accelerator structure vacuum vessel schematic. The waveguide input and output ports, as well as the bottom of the vacuum chamber were mounted with vacuum windows.

Experimental Results

Because the electron beam used to generate wakefields in the PBG structure is bunched at the 17.14 GHz rf frequency, all wakefields observed were at integer multiples of 17.14 GHz. This was verified with wavemeter, waveguide filter, and heterodyne receiver measurements.

Very good agreement has been observed between measurements made on the output port with a matched input port, and the corresponding predictions from traveling wave theory; Fig. 4 displays absolute power measurements at 17.14 GHz and the theory prediction. Results for the

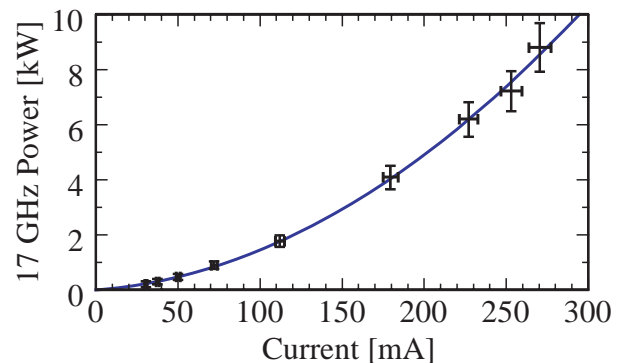

Figure 4: Power observed on output port with matched input port, at 17.14 GHz, versus current. Traveling wave theory expression shown in blue with data given as black bars. Current error measured as shot to shot variation; power error calculated as a combination of statistical variation, calibration systematic errors, and beam current error.

Ka-band diode detector observing on the output coupler port are shown in Fig. 5. Good agreement is obtained with a quadratic fit, with error arising from both the statistical diode signal variation and shot to shot current fluctuation. Wakefield measurements were made in a variety of config-

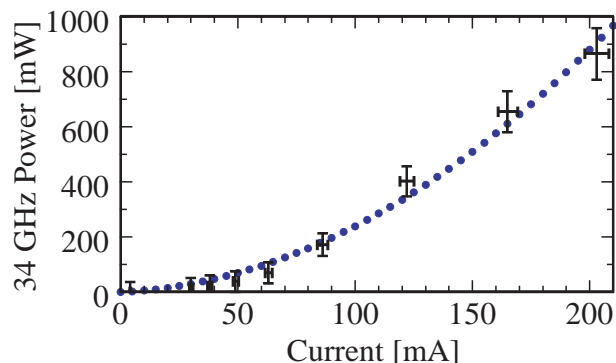

Figure 5: Power observed on output port with matched input port, at 34.28 GHz, versus current. Quadratic fit to data shown in blue dashed line with data given as black bars.

urations as functions of beam position and current; Table 1 shows a sampling of the detector configurations and power measurements for an average beam current of 100 mA.

Frequency	Location	Power Measured
17.14 GHz	Output Port	1.46 kW
	Chamber	21 mW
34.28 GHz	Output Port	240 mW
	Chamber	240 mW

Table 1: Power measurement summary. Frequency of observed wakefields, location of detector, fully calibrated power level detected for 100 mA average beam current.

DISCUSSION AND CONCLUSION

Traveling wave theory with cold test measurements predicts 1.54 kW of power at the structure port for 100 mA current, in comparison to the 1.46 kW measured in experiment. The PBG accelerator structure was designed and built to support a 17.14 GHz fundamental mode with group velocity and Q as discussed earlier. Measured values are close to these design values, and the very good agreement between power observation and prediction confirms that a traveling wave mode is being excited by the electron beam. To better understand HOM wakefields in PBG structures, full wakefield simulations are underway. These simulations are being performed at SLAC using the code *T3P*, and at STAAR, Inc., using *Analyst*.

The beam induced wakefield measurements at 34.28 GHz, show that measureable power is being radiated into HOMs, and that if these wakefields are not damped they escape the structure. Damping these HOMs will prevent the power from escaping the immediate

area of the structure only to be reflected back and act incoherently on the beam. The dominance of diffractive loss makes damping of HOMs in PBG structures relatively straightforward, and future work on implementing external damping schemes is being pursued.

Future work also considers other aspects of high gradient structure design such as electric field breakdown, and magnetic field pulsed heating. A single cell, standing wave breakdown experiment has been designed at 11.424 GHz for construction and high power testing at SLAC; design work to mitigate pulsed heating on the inner row of metallic rods is also being done.

ACKNOWLEDGEMENTS

The authors gratefully acknowledge useful discussions with Jake Haimson and Amit Kesar, and the engineering support of Ivan Mastovsky.

REFERENCES

- [1] D. R. Smith, N. Kroll, and S. Schultz, *Advanced Accelerator Concepts*, ed. P. Schoessow, AIP Conf. Proc. No. 335 (1995), pp. 761-776.
- [2] M. A. Shapiro, W. J. Brown, C. Chen, J. R. Sirigiri, E. I. Smirnova, and R. J. Temkin, in *Proceedings of the 2001 Particle Accelerator Conference*, (IEEE, Piscataway, NJ, 2001), pp. 930-932.
- [3] E. I. Smirnova, I. Mastovsky, M. A. Shapiro, R. J. Temkin, L. M. Earley, and R. L. Edwards, *Phys. Rev. ST Accel. Beams* **8**, 091302 (2005).
- [4] E. I. Smirnova, A. S. Kesar, I. Mastovsky, M. A. Shapiro, and R. J. Temkin, *Phys. Rev. Lett.* **95**, 074801 (2005).
- [5] R. A. Marsh, M. A. Shapiro, E. I. Smirnova, and R. J. Temkin, in *Proceedings of the 2007 Particle Accelerator Conference*, (IEEE, Piscataway, NJ, 2007), pp. 3002-3004.
- [6] R. B. Neal, *J. Appl. Phys.* **29**, 1019 (1958).
- [7] J. Haimson, *Nucl. Instrum. & Methods Volume 33, Issue 1*, 1 March 1965, pp. 93-106.
- [8] W. J. Mulligan, S. C. Chen, G. Bekefi, B. G. Danly, and R. J. Temkin, *IEEE Trans. Electron Devices* **38**, 817 (1991).
- [9] J. Haimson, B. Mecklenburg, G. Stowell, K. E. Kreisler, and I. Mastovsky, in *Proceedings of the 1999 Conference on High Energy Density Microwaves*, AIP Conf. Proc. No. 474 (AIP, New York, 1999), p. 137.
- [10] J. Haimson, B. Mecklenburg, in *Proceedings of the 1995 Particle Accelerator Conference* (IEEE, Piscataway, New Jersey, 1995) pp. 755-757.