

MAIN FIELD TRACKING MEASUREMENT IN THE LHC SUPERCONDUCTING DIPOLE AND QUADRUPOLE MAGNETS*

P. Xydi¹, N. Sammut^{1,2}, R. Alemany Fernandez¹, L. Bottura¹, G. Deferne¹, M. Lamont¹, J. Miles¹, R. Mompo¹, M. Strzelczyk¹, W. Venturini Delsolaro¹

1 - CERN, Geneva, Switzerland; 2- University of Malta, Msida MSD 2080, Malta

Abstract

One of the most stringent requirements during the energy ramp of the Large Hadron Collider (LHC) is to have a constant ratio between dipole-quadropole and dipole-dipole field so as to control the variation of the betatron tune and of the beam orbit throughout the acceleration phase, hence avoiding particle loss. To achieve the nominal performance of the LHC, a maximum variation of ± 0.003 tune units can be tolerated. For the commissioning with low intensity beams, acceptable bounds are up to 30 times higher. For the quadropole-dipole integrated field ratio, the above requirements translate in the tight windows of 6 ppm and 180 ppm, while for dipole differences between sectors the acceptable error is of the order of 10^{-4} . Measurement and control at this level are challenging. For this reason we have launched a dedicated measurement R&D to demonstrate that these ratios can be measured and controlled within the limits for machine operation. In this paper we present the techniques developed to power the magnets during the current ramps, the instrumentation and data acquisition setup used to perform the tracking experiments, the calibration procedure and the data reduction employed.

INTRODUCTION

The LHC's stringent demands during injection, acceleration, squeeze and collision require constant quadropole-dipole and dipole-dipole field ratios. This requirement is essential to control the betatron tune and to ensure that the beam orbit remains the same throughout the acceleration phase.

To this end CERN launched a measurement campaign during October-November 2007. Two dipoles (MB2624 and MB2598) and a quadropole (SSS064) were installed in three test benches at CERN. The main aim was to verify whether FiDeL [1,2] -the model for the field description of LHC- can be used for an accurate generation of the current ramps of the main superconducting magnets for producing the expected magnetic fields. In order to test the system integration, the whole chain was controlled by the LHC Software Architecture (LSA) [3] as will be done during the standard operation in the CERN Control Centre (CCC).

MEASUREMENT SETUP

Measurement Coils

Each magnet was equipped with a coil measurement system [4]. The shafts installed in the apertures of the dipole magnets are made up of 13 sectors which provide the necessary rigidity for mounting two tangential and

one central pick-up coils of 36 turns each. The average magnetic area of each coil is approximately $0.352 \text{ m}^2/\text{coil}$ (calibrated within 10^{-4} m^2), its length 1.15 m/coil (calibrated within 10^{-3} m) and between them there is a 110 mm gap which houses the rotating bearings and the wire inter-connections. The shafts installed in the apertures of the quadropole are made up of 6 sectors each carrying 5 coils of 64 turns each. The average magnetic surface of each coil is approximately $0.381 \text{ m}^2/\text{coil}$, its length 0.7 m/coil and the gap between them 110 mm. For the main field tracking the pick-up coils were used in static mode, as flux meters.

Data Acquisition System

The core of the acquisition system used was a series of VME-PDI's (Portable Digital Integrators). In stationary mode, the integrators measure the flux change linked with the coils during magnet ramps. They were triggered at 1Hz by an external, frequency controlled function generator used to ensure synchronisation between the integration time and the current given by the power supply. The PDI's were set with a fixed gain and were configured and read-out by a Sun Ultra workstation through a MXI interface. The measurement was performed at the same time for both apertures of the magnets.

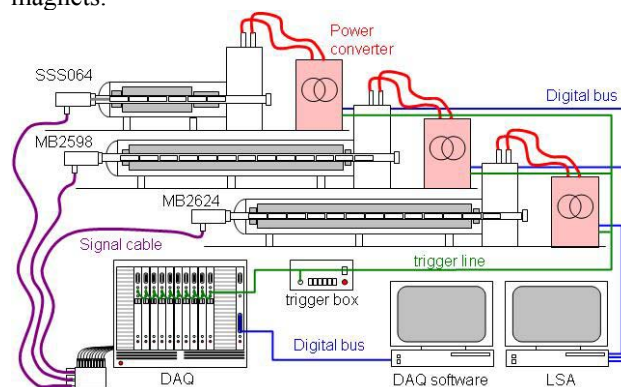

Figure 1: Set-up used for the measurement of the main field strength using the fixed coils.

Magnet Characterization and FiDeL modelling

FiDeL is composed of static and dynamic field models. For the extraction of the static FiDeL parameters [1], the magnets were first characterized by measuring them during a stepped cycle (loadline cycle) of 10A increments up to 3000A and steps of 200A thereafter with the rotating coils in the standard compensating mode. These characterisation cycles were preceded by a pre-cycle which was used to put the magnets in a known magnetic state. For the parameters' extraction only the ramp-up data were used.

For the extraction of the dynamic FiDeL parameters [2], the magnets were characterised with an LHC cycle which is a simulation of the real cycle of the machine. The LHC cycle has a ramp-up of 10A/s to injection current with a duration of 1000s on the injection plateau. This is followed by a standard LHC PELP (Parabolic Exponential Linear Parabolic) ramp, a 1000s top plateau at the nominal current of 11850A, and a ramp-down to minimum current (350A) at 10A/s. The LHC cycle was, also, preceded by a pre-cycle.

LSA Control System

In the CERN Control Center (CCC) FiDeL is implemented via the LSA. LSA consists of a set of interdependent modules, providing a coherent set of functionalities, from the lowest level services up to the client applications.

Several applications, parts of the LSA core, were used to drive the main field tracking tests. LSA prepared the current settings for the magnets based on calibration curves $I(B)$, controlled the interaction with the power converters and allowed the monitoring of process variables during the experiments. Running several power converters at the same time was, also, done with a very good accuracy.

MEASUREMENTS PERFORMED AND DATA TREATMENT PROCEDURE

Measurement Cycles

The main field tracking accuracy was measured in several test runs consisting of current cycles simultaneously performed on the dipoles and on the quadrupole. A typical current run consisted of a pre-cycle and several standard LHC cycles chained all in supercycles, with no interruption. In total, 22 LHC cycles, preceded by a total of 9 pre-cycles, were performed.

Data Treatment

For the determination of the main field component the voltage signals measured on the coils at each trigger were first normalized with the gains of the amplifier chains. The voltage offset was computed at bottom and top plateaus and removed from the measured voltages by means of a linear interpolation with the current [6]. The coil flux was computed as the time integral of the induced voltages and the instant values of the local field strength were obtained using the coil sensitivities. For obtaining the values of the absolute field strength an integration over the whole magnetic length was necessary. Since all power converters were synchronized, the values of the ratio B_2/B_1 were computed by taking the ratio of the numerical values of B_1 and B_2 at each time-stamp. For all runs, the calculations were confined to the ramp-up part of the LHC cycles.

The quality of the results improved considerably when the slopes of the measured B_n ($n=1,2$) field strengths versus current were corrected to match the slopes of the respective curves measured with rotating

coils. Before calibration, the difference between rotating and fixed coil measurements was 10^{-4} Tm/A. This technique is equivalent to eliminating errors introduced in the results due to the uncertainty in the extrapolation of the coil geometry to operating conditions, misaligned shafts with respect to the field axis and unquantified effects of read-out electronics. Figure 2 shows the result of calibrating the fixed coil measurement with the rotating coil measurement in terms of the main field transfer function (TF); defined as the ratio of the generated field to the operating current.

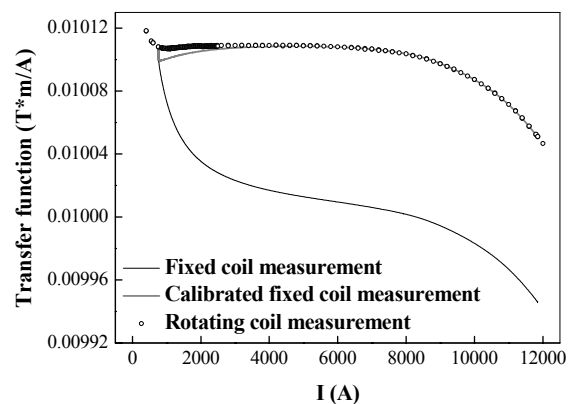

Figure 2: Main field transfer function measured on aperture 1 of dipole MB2624 with fixed and rotating coils. The result of calibration of the fixed coil measurement with the rotating coil measurement is also presented.

MEASUREMENT UNCERTAINTY OF THE MAIN FIELD

Estimation of the 'Instrumentation Error'

The results of the October-November 2007 tracking measurement campaign, quoted in [5], showed that the B_2/B_1 ratio is definitely within the tight bounds for commissioning and very close to the ones for nominal operation. However, these tight windows for the maximum allowable variation of the ratio B_2/B_1 had to be compared with the uncertainty of our results due to measurement errors. The voltage signals measured on the coils were affected by electronic and electromagnetic noise, with rms amplitude values within the μ V scale. For the calculation of the dipole and quadrupole field strengths, the measured voltages were corrected by subtracting the mean value of the noise by means of a linear interpolation with the current, as in [6]. However, this method of correcting the voltage signals, although effective was not completely successful, due to the uncertainty in the correction factors.

A dedicated error study showed that the residual voltage offset, when integrated, leads to a statistical uncertainty of $1.6 \cdot 10^{-3}$ T·m for the main dipole field and to an uncertainty of $1.2 \cdot 10^{-3}$ T·m (at $R_{ref}=17$ mm) for the main quadrupole field, at nominal current. The values of

the integrated field for a dipole and a quadrupole at nominal current are respectively 119 T·m and 11.7 T·m at $R_{ref}=17\text{mm}$. Furthermore, the uncertainty on the B_2/B_1 ratio, namely the ‘instrumentation error’, is not constant (Figure 3). Its values vary from $1\cdot 10^{-6}$ to $2.5\cdot 10^{-5}$ leading to an uncertainty of 0.01 to 0.25 units in the results which is comparable to the order of allowable variation of B_2/B_1 ratio for the machine’s operation. However, the ‘instrumentation error’ values don’t change from cycle to cycle since they depend only on the measurement configuration, and the values reported here apply to the whole campaign.

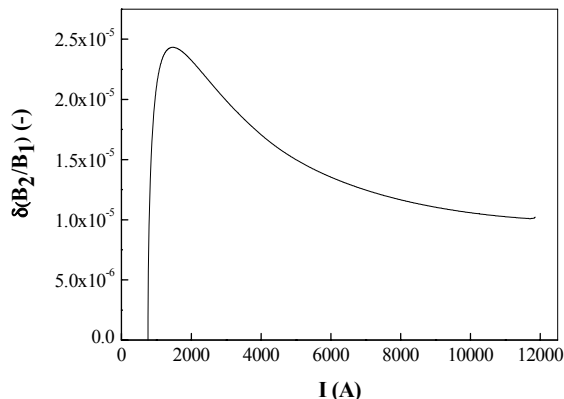

Figure 3: Relative variation of the ‘instrumentation error’ $\delta(B_2/B_1)$ with respect to the injection current for apertures 1 of MB2624 and SSS064 as a function of current.

Cycle-to-cycle Reproducibility

In Figure 4, the cycle-to-cycle reproducibility of the main field tracking is shown. Reproducibility $\Delta(B_2/B_1)$ was calculated as the variation of B_2/B_1 ratio between two subsequent LHC cycles. Reproducibility can be verified in this way since current ramps were the same for all tests performed.

The ideal change of B_2/B_1 ratio between two cycles should be zero giving zero variation of results from cycle to cycle; current measurements showed that the reproducibility from cycle to cycle is within the very tight targets derived from the tune tolerance.

CONCLUSIONS

The tracking experiments have demonstrated that measurement and control of B_2/B_1 ratio is possible within the stringent limits for the LHC operation. FiDeL can be used for an accurate generation of the current ramps of the main superconducting magnets for producing the expected magnetic fields. The results showed that the quadrupole-dipole field ratio can be kept constant within the range to be achieved for beam commissioning and quite close to the range necessary to maintain the maximum allowable tune variation for the nominal LHC performance. For these results, the measured B_n ($n=1,2$) field strengths results were calibrated with rotating coil measurements.

A dedicated error study showed that integration of the residual noise leads to statistical uncertainties of the order of the allowable variation of B_2/B_1 ratio for the machine’s operation. However, these uncertainties don’t change from cycle to cycle since they depend only on the measurement configuration. On the other hand, the successful control of the quadrupole-dipole field ratio led to a cycle-to-cycle reproducibility within the very tight targets demanded.

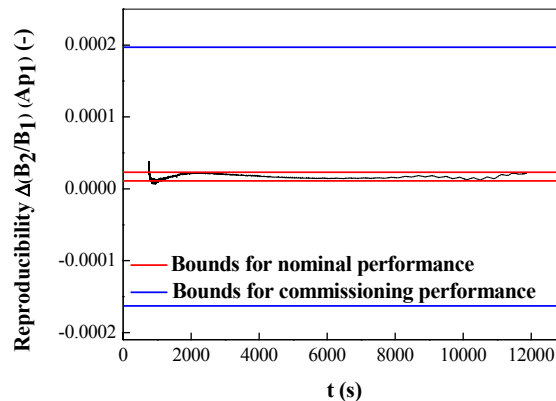

Figure 4: Cycle-to-cycle variation of B_2/B_1 ratio for apertures 1 of MB2624 and SSS064. The bounds for nominal (innermost solid, red lines) and commissioning operation (outermost solid, blue lines) are also plotted.

REFERENCES

- [1] N. Sammut, L. Bottura and J. Micallef, “A Mathematical Formulation to Predict the Harmonics of the Superconducting LHC Magnets”, Phys. Revs ST - Accel. Beams - Vol. 9, No.1, 012402, January 2006.
- [2] N. Sammut, L. Bottura, P. Bauer, T. Pieloni and J. Micallef, “Mathematical Formulation to Predict the Harmonics of the Superconducting Large Hadron Collider Magnets: Part II - Dynamic Field Changes and Scaling Laws”, Phys. Revs ST - Accel. Beams - Vol. 10, No.8, 082802, August 2007.
- [3] M. Lamont and L. Mestre, “LHC Era Core Control Application Software”, Proceedings to the ICALEPCS’2005, Geneva, October 2005.
- [4] J. Billan, L. Bottura, M. Buzio, G. D’Angelo, G. Deferne, O. Dunkel, P.Legrand, A. Rijllart, A. Siemko, P. Sievers, S. Schloss and L. Walckiers, “Twin Rotating Coils for Cold Magnetic Measurements of 15 m Long LHC Dipoles”, IEEE Transactions on Applied Superconductivity, vol. 10, pp. 1422-1426, December 1999.
- [5] N. Sammut et al, these proceedings.
- [6] V.Granata et al., “Magnetic Field Tracking Experiments for LHC”, Proceedings to European Particle Accelerator Conference, Lucerne Switzerland July 2004.