

LATEST PROGRESS IN INSERTION DEVICES AT ACCEL INSTRUMENTS

D. Doelling, H. P. Vogel, B. Fischer, A. Hobl, P. Komorowski, D. Krischel, M. Meyer-Reumers, ACCEL Instruments GmbH, Bergisch Gladbach, Germany

Abstract

ACCEL Instruments GmbH has designed, manufactured, assembled, and tested several insertion devices for synchrotron light sources and free electron lasers around the world.

ACCEL has been awarded for the construction of two identical In – Vacuum Undulators for the ALBA/CELLS synchrotron light source in Barcelona, Spain. The design originates from the standard ESRF IVU based on the license agreement with the ESRF ID group. The status of the design work is summarized.

Also ACCEL Instruments is manufacturing two granite measurement benches for the FERMI project at Elettra in Trieste, Italy. Both benches are designed to characterize Insertion Devices in a fast and accurate way. Both benches are right under commissioning and will be shipped in the next weeks.

A full functional prototype Hybrid Undulator for the European X-FEL project in Hamburg was delivered successfully and, as the first device, in full compliance with the technical specification.

Also the industrial study requested by DESY for the adaptation of the design towards a large series production of 5m long undulators for the European X-FEL was completed as the first one in full compliance with the DESY specification and the basic conclusions are presented.

INTRODUCTION

ACCEL has been awarded a contract to design, manufacture, assemble and test two identical pure permanent magnet in-vacuum undulators for ALBA / CELLS. The magnetic design studies carried out by ALBA were taken and re-simulated in order to refine the design in terms of overall magnetic performance. The frame design originates from ACCELs licence agreement with the ID group of the ESRF [1] and is adapted to the needs of ALBA.

Elettra contracted ACCEL to produce two standard ESRF measuring benches. The ESRF design as well as the changes implemented in ACCELs own bench were taken as a reference. Also the experience collected with our bench was taken into account to improve the design.

A 2m hybrid prototype including an industrial study was contracted to ACCEL from DESY. We delivered that device with full functionality as the first company to our customer, meeting the technical specification. Also the industrial study, aiming on the costs, ease of assembly for a large series production of up to 120 5m long devices was delivered as the first one according to the specification

IN VACUUM UNDULATORS

Figure 1 shows a 3D CAD model of the IVU for ALBA. The technical specification is listed in table 1.

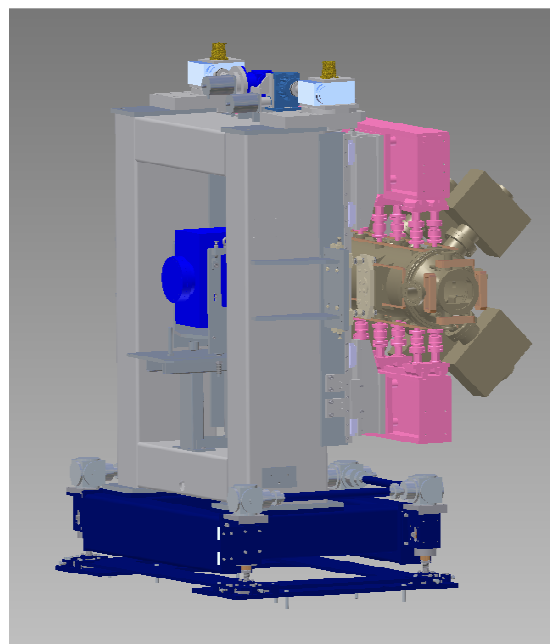

Figure 1: Layout of ALBA in-vacuum undulator

Table 1: specification of the IVU for ALBA

Specification	Value
Number of periods	77
Period length	21.6 mm
Magnetic field @ 5.7 mm	0.79 T
K value	1.6
Gap range	5 mm to 30 mm
Gap reproducibility	1 µm
Linear encoders	2 incremental between outer girders
Rotary encoders	2 absolute at both spindles and 1 at sub-frame
Taper possibility	Phase shifter gear box with power cutting limit switches
Correction coils	4 long and 8 small coils

ACCEL's design includes two incremental linear encoders and two absolute rotary encoders in order to determine any backlash between the motors and outer girders. The absolute rotary encoders are acting also as a reference in case of a power failure.

A phase shifter gear box mounted between the main stepper motor and one gear box of the vertical spindle allow for aligning the girders in parallel and also for tapering the device and expand the usage of the device for the users. The hardwired limit switches are cutting the motor power of the tapering system in order to prevent the device from any damage.

Detailed FEA analysis was carried out by ACCEL in collaboration with ALBA, aiming on the bending of the inner magnetic girders due to the magnetic forces. Several approaches were analysed as shown in table 2.

Table 2: FEA approaches

	inner girder material	link rods material	outer girder material	inner girder considered	link rods considered	outer girder considered	Absolut Result (µm)	Gap variation Result (µm)
ESRF	aluminium	stainless steel	steel	X	X	X	9.7	ca. 9
ESRF	aluminium	stainless steel	steel	X	X	stiff	6.0	4.9
1. approach	aluminium	stainless steel	steel (full)	X	X	X	6.9	4.8
2. approach	aluminium (full)	stainless steel	steel (full)	X	X	X	4.3	2.7
3. approach	aluminium (full)	stainless steel	steel (3 wall)	X	X	X	6.6	6.3
last attemp	aluminium (full)	stainless steel	steel (3 wall, 30mm moved)	X	X	X	5.6	4.8

According to the calculation of the inner girders vs. phase error, done by ALBA, depicted in figure 2, we have chosen a double T shape steel outer girder, 6 link rod pairs positioned in order to minimize the bending and an aluminium inner girder for a better thermal contact during baking and cooling the magnets. The FEA analysis result for that solution is shown in figure 3.

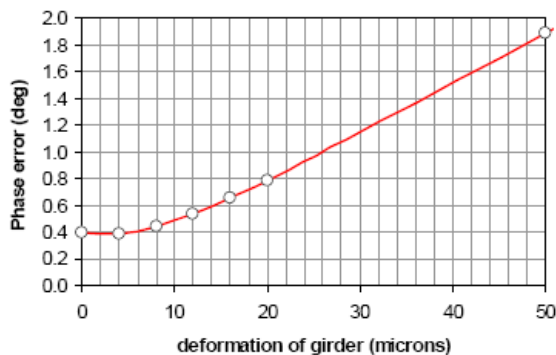

Figure 2: phase error vs. deflection of girders [2]

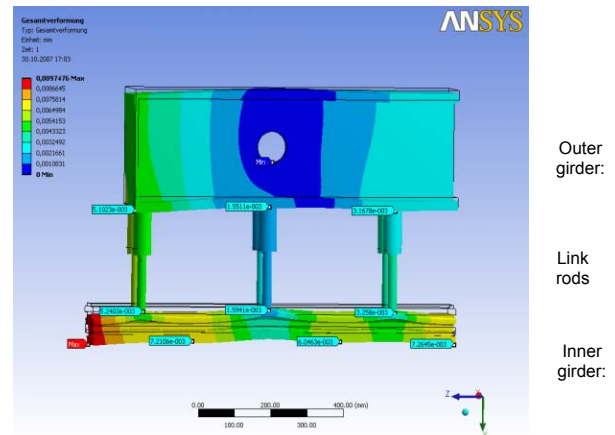

Figure 3: FEA analysis result

The results clearly depict that one has to take into account the two point support of the outer girder and also the local stiffness of the inner girder.

GRANITE MEASURING BENCHES

ACCEL has been awarded a contract to design, manufacture, assemble and test two granite measuring benches for Elettra. The design includes the newest standard ESRF design and in addition designs improvements by ACCEL.

The specification is listed in table 3. Both benches are right under commissioning and will be under factory acceptance test and delivery in the next few weeks.

Table 3: specification of the benches for Elettra

Specification	Value
Length	3.5 m and 5.5 m
Flatness of hall probe bench	$\leq \pm 20 \mu\text{m}$
Roll of hall probe bench	$\leq \pm 15 \mu\text{rad}$
Pitch and yaw of hall probe bench	$\leq \pm 10 \mu\text{rad}$
Perpendicularity of all hall probe axes	$\leq \pm 50 \mu\text{rad}$
Pitch and yaw of all hall probe and flip coil axes	$\leq \pm 50 \mu\text{rad}$
Perpendicularity of all flip coil axes	$\leq \pm 20 \mu\text{rad}$
Flip coil	20 windings
Hall probes	3D full calibration in all three axis

There were two major improvements. One was to have a full calibrated hall probe also in the x direction (horizontal) for the APPLE II devices. This was solved, also by the ESRF, by using a smaller layout of the probe holder including also flexible connections. That allows to turn the x-axis fully into the magnetic field of a calibration magnet.



Figure 4: flexible hall probe design

The second improvement was to have some alignment possibilities for the hall probe arm. ACCELS design allows to align the hall probe in the pitch and roll direction of an undulator in front of the measuring bench. This is shown in figure 5.

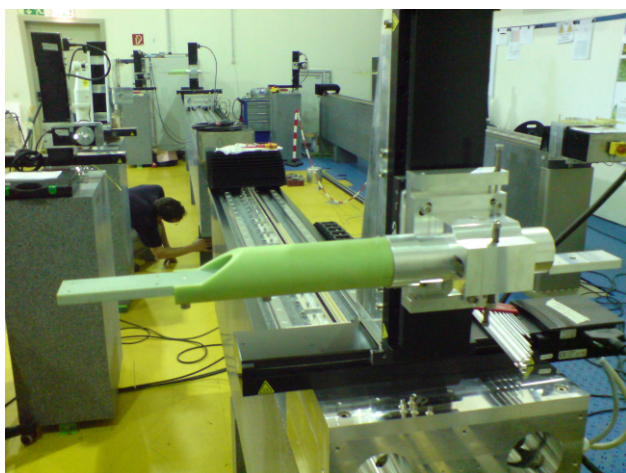

Figure 5: Alignment possibilities for the hall probe arm

Figure 5 also shows the very occupied ID laboratory. To the right you see our own 7 m long measuring bench. In front you see the 3.5 m long bench and in the back the 5.5m long bench, both for Elettra.

HYBRID UNDULATOR PROTOTYPE

Figure 8 shows the prototype undulator produced for the PETRA III and the X-FEL project. The scope of work included the implementation of design changes in order to allow a series production based on the DESY design. The high precision of the gap positioning and synchronised movement of the 4 servo motor gap controllers is better than 1µm.



Figure 6: 2-m prototype for the PETRA III / X-FEL project prototype

The contract also covers an industrial study on the series production of up to 120 undulators for the European X-FEL project to be realized in Hamburg, Germany [3]. ACCEL has delivered as the first out of three suppliers the undulator as well as the study in full accordance to the specification of DESY.

The main outcome of the study is listed in the following:

- more complex control PC to an more favourable price
- more easy machining of the frame
- more easy assembly procedures for the frame
- more easy alignment and integrated fiducialisation points
- high cost reduction in a series production analysed

REFERENCES

[1] <http://www.ESRF.eu>
 [2] Graph provided by ALBA / CELLS.
 [3] <http://www.xfel.eu/de/>