

# BENCH-TOP IMPEDANCE MEASUREMENTS FOR A ROTATABLE COPPER COLLIMATOR FOR THE LHC PHASE II COLLIMATION UPGRADE\*

Jeffrey Claiborne Smith<sup>†</sup>, Karl Bane, Eric Doyle, Lew Keller, Steve Lundgren, Tom Markiewicz, Cho-Kuen Ng, Liling Xiao (SLAC, Menlo Park, California)

## Abstract

Simulations have been performed in Omega3P to study both trapped modes and impedance contributions of a rotatable collimator for the LHC phase II collimation upgrade. Bench-top stretched coil probe impedance methods are also being implemented for measurements on prototype components to directly measure the low frequency impedance contributions.

The collimator design also calls for a RF contact interface at both jaw ends with contact resistance much less than a milliohm in order to limit transverse impedance. DC resistance measurements in a custom built test chamber have been performed to test the performance of this interface.

## INTRODUCTION

In the LHC, longitudinal beam impedance is not expected to be a problem and for all components only the transverse impedance is of specific concern [1]. Although broadband impedance must be controlled, specific concern is at low frequencies. In particular, 8 kHz, corresponding to the non-integer part of the betatron tune for the planned operating point of 0.3, and 20 MHz, corresponding to the frequency bandwidth of the transverse feedback system. Other higher harmonics are also of a concern. At these low frequencies the traditional resistive wall impedance formulas do not necessarily give accurate approximations due to the inductive bypass effect and more accurate formulas have been developed [2].

## ESTIMATION OF ROTATABLE COLLIMATOR IMPEDANCE CONTRIBUTION

Fig. 1 illustrates the current collimator design with RF shielding. Further details of the collimator design can be found in a different paper [3]. The interconnect between the jaw and the transition piece requires a sliding RF contact seal. There is also a design to include longitudinal RF seals along the top and bottom of the jaws insulating the chamber behind the jaws from EM fields produced from the beam if it is found that trapped mode heating will be large.

The Vos formula [2] was used to calculate the resistive wall component for each collimator section. This includes the jaws proper and all transition pieces including the thin

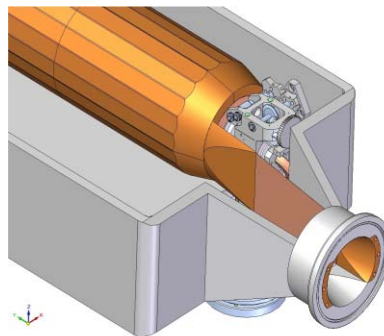

Figure 1: Diagram of the collimator upstream end showing jaw facet and taper, transition piece, flexible foil and flange transition. Only one of the two jaws is shown.

flexible foil. The geometric impedance can be difficult to calculate for this complex geometry. As a first estimate, the small angle Yokoya formula for a round collimator [4] was used. In both the resistive wall and geometric cases, the Yokoya factor of  $\frac{\pi^2}{12}$  was used to convert from cylindrical symmetry to flat plates.

At full insertion the collimator half gap will be 1 mm. At such a small gap the resistive wall impedance of the metallic jaws is much larger than the geometric component of the tapers and transition pieces. This is with the exception of the azimuthal contact seal which is only 11 mm from the beam and requires a very small contact resistance to limit its contribution to the overall impedance. Fig. 2 gives the total real and imaginary components to the transverse impedance for a 1 mm half gap. The solid curves show the total impedance, adding up all contributions including the jaws, transition pieces and RF seals. The dashed curves show the impedance contribution due only to the jaws. At very low frequencies the added contribution due to the contact resistance of the azimuthal RF seal is evident in the real curve. At very high frequencies the geometric impedance of the tapers begins to be evident in the imaginary curve. Better estimates could be obtained for the contact resistance and geometric components. These rough estimates are sufficient to demonstrate that the jaw resistive wall component is dominant over the frequency range of concern.

## OMEGA3P SIMULATIONS

The complex geometry results in many different chamber shapes along the beam path. The beam first sees a transition piece - D04 Instabilities - Processes, Impedances, Countermeasures

\* Work supported in part by Department of Energy contract DE-AC02-76SF00515

<sup>†</sup> js344@slac.stanford.edu

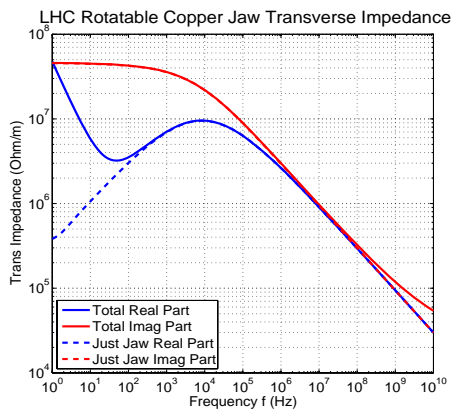

Figure 2: Transverse Impedance for the LHC rotatable collimator showing both the total real and imaginary impedance and just the contribution due to the jaws.

sition piece from the round beam pipe to square, then a flexible foil used to connect the moving jaw ends to the rigid vacuum chamber and finally through a second transition piece to the jaw proper. There are many opportunities for trapped modes to develop resulting in either local heating or worse yet, impedance contributions to the beam path. To better understand the trapped modes and impedance contributions an effort has begun to simulate the collimator in Omega3P [5] which was developed at SLAC and uses the finite-element method and parallel processing.

Trapped modes will vary depending on the jaw gap. Results have been obtained so far for two symmetrical cases: both jaws fully inserted with a 1 mm half gap and fully extracted with a 21 mm half gap. In the first case, no large EM fields are established along the beam path because of the small gap size. However, fields are established between the jaw and the chamber wall. The total loss factor was found to be  $3.16 \times 10^5$  V/C and the total power absorbed in the trapped modes is 3.3 mW. This is very small especially compared to the 23 kW of power absorbed by the beam collimation. For the larger gap, the total loss factor was found to be  $5.33 \times 10^7$  V/C and the total power absorbed is 0.56 W. A much larger gap exists along the beam path in this case establishing a larger EM field pattern. Further studies will be performed to investigate any areas with large local heating. Trapped modes will also be investigated for one other configuration, a asymmetric condition where both jaws are displaced by up to 5 mm but still maintaining the 1 mm half gap. A different mode pattern may develop in this case.

Given the small heating due to trapped modes discovered so far the current conclusion is that longitudinal RF seals along the top and bottom of the Jaw surfaces will not be necessary. If it is determined that a significant amount of localized heating will occur then longitudinal RF seals can be re-investigated to seal off the back sides of the collimator chamber.

## BENCH-TOP MEASUREMENTS

For low frequencies below 10 MHz the standard stretched wire transmission line method is subject to low signal to noise ratios. Better sensitivity can be achieved by using a loop instead [6]. This method is being implemented to measure the low frequency transverse impedance of the rotatable collimators. The method uses a wound coil of length  $L$ , width  $\Delta$  and  $N$  turns inserted in the Device Under Test (DUT). This coil then establishes a dipole EM field in the DUT which in turn induces a voltage in the loop increasing its impedance. The impedance in the coil can then be measured with a VNA or LCR meter. At low frequencies below 100 kHz, LCR meters have been found to give higher signal to noise ratios. The transverse impedance of the DUT can then be found from

$$Z_T = \frac{c}{\omega} \frac{Z^{DUT} - Z^{ref}}{N^2 \Delta^2} \quad (1)$$

where  $\omega$  is the angular frequency excited by the LCR meter,  $Z^{DUT}$  is the measured impedance in the DUT and  $Z^{ref}$  is the measured impedance in a reference. If the impedance can be established separately in the reference (such as from first principles for simple geometries) then the transverse impedance in the DUT can be deduced.

To verify the performance of our setup comparisons have been made with results obtained by Roncarolo *et al.* [7]. This test amounted to measuring the inductive by-pass in two graphite blocks assembled parallel to each other with the coil in-between. Results are shown in Fig. 3. Plotted along with the data is the theoretical curves using the Vos formulas [2] and the classic thick wall formula. Agreement with the Vos curves is evident, however, our results are not in as good of agreement as observed by Roncarolo. The differences are being investigated. Precise alignment of the coil in the plates is essential and may be one source of error in our measurement.

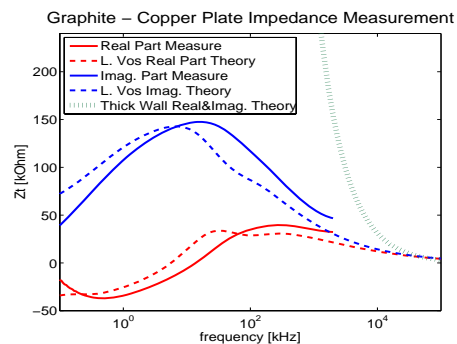

Figure 3: Measuring the Inductive By-Pass effect in two graphite and copper plates.

Future plans for this measurement technique are to first apply it to mock-ups of the transitions pieces for the phase II collimators to measure the contribution to the impedance due to contact resistance and geometry. Then to perform

measurements on the first fully functional prototype to verify acceptable impedance characteristics.

## CONTACT RESISTANCE MEASUREMENTS

The interconnect between the jaw and the transition piece results in a sliding contact 11 mm away from the beam axis when the jaw is fully inserted. Without special care in designing the sliding RF contact a large transverse impedance contribution could result. The contribution of an element with resistance  $R_{rf}$  to the transverse impedance is given by [8]

$$\Delta R_{\perp} = R_{rf} \frac{2c}{b^2 \omega_{\beta}} \quad (2)$$

where  $c$  is the speed of light,  $b = 0.011$  m is the distance between the contact and the beam axis and  $\omega_{beta}$  is the lowest, most unstable slow wave betatron frequency. With the proposed operating point for the LHC,  $\omega_{\beta}/2\pi \approx 7$  kHz [8]. Using the same impedance budget as for the vacuum interconnects of  $3.4\text{ k}\Omega/\text{m}$  we obtain the objective DC resistance for each jaw contact as  $0.03\text{ m}\Omega$ . Considering each jaw doesn't envelop the entire azimuthal plane around the beam, the actual acceptable contact resistance can be higher at about  $0.2\text{ m}\Omega/\text{cm}$  along the contact surfaces.

The jaw is glidcop and the transition piece is copper. A sliding RF contact with very low contact resistance must be chosen that will hold up to the  $\sim 20$  year operational lifetime of the collimators without serious degradation. A helical contact spring mounted in a groove in the transition piece is the current design. A bare BeCu spring pressed against Cu would quickly cold-weld so appropriate coatings are necessary. Following the investigations conducted by Calatroni *et al.* [9], the most desirable coating surfaces are rhodium on the jaw and transition piece and silver on the spring. Bench-top measurements were performed by Calatroni [9], but the target resistance per finger was about  $1\text{ m}\Omega$ . Given our choice of spring is a much different geometry and the contact resistance must be five times lower at  $0.2\text{ m}\Omega/\text{cm}$  it was decided to perform our own measurements to verify we could achieve our resistance goals.

A small vacuum chamber was designed for use as an RF contact test chamber as illustrated in Fig. 4. This chamber contains two mechanical feedthroughs allowing for adjusting the contact force as well as sliding the contacts along the anvil. The four-wire method is then used with a HP 4275A Multimeter to measure the resistance across the contact. After removing the bulk resistance of the cradle and anvil of about  $0.017\text{ m}\Omega$ , the target resistance of  $0.02\text{ m}\Omega/\text{cm}$  was found to be achievable with Rh/Ag coatings. Wear and tear on the coil due to sliding of the jaws may deteriorate the resistance. Results so far have found no deterioration after successively sliding the anvil back and forth for a full integrated travel of 9 cm. However, due to a faulty design in the feedthrough mechanisms, the anvil and cradle were not stable during the sliding motion. Nevertheless, the results as they stand are consistent with previous

studies on wear cycling [9] and excessive degradation of performance is not expected. More results with an updated feedthrough design are forthcoming.

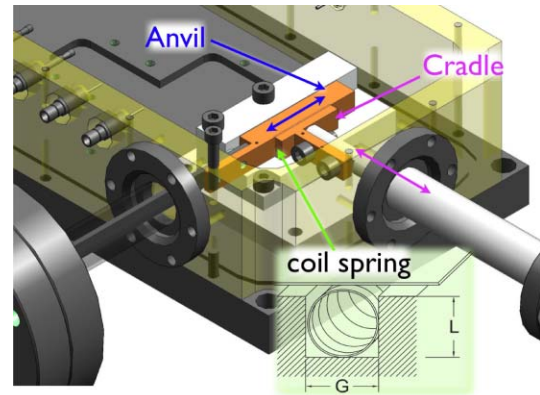

Figure 4: Test Chamber for testing RF seal materials and coatings.

## ACKNOWLEDGMENTS

The authors are greatly indebted to Fritz Caspers, Elias Métral, Benoit Salvant and Federico Roncarolo for productive conversations on the LHC collimator impedance and experimental methods. Dan Van Winkle, Jim Lewandowski and Doug McCormick were very helpful in obtaining and developing the experimental equipment.

## REFERENCES

- [1] LHC Design Report, CERN-2004-003 (2004)
- [2] Koschik, A, *et al.*, "Transverse Resistive Wall Impedance and Wake Function with 'Inductive Bypass'," Proceedings EPAC04, **WEPLT023** (2004)
- [3] Smith, J.C. *et al.*, "Design of a Rotatable Copper Collimator for the LHC Phase II Collimation Upgrade," EPAC08 MOPC096 (2008)
- [4] Yokoya, K. CERN-SL-90-88-AP (1988)
- [5] Ng, C. *et al.*, "State of the art in EM Field Computations," EPAC067 invited oral presentation.
- [6] Mostacci, A, *et al.*, "Bench Measurements of Low Frequency Transverse Impedance," Proceedings PAC03 (2003)
- [7] Roncarolo, F., "Comparison between Laboratory Measurements, Simulations and Analytical Predictions of the Resistive Wall Transverse Beam Impedance at Low Frequencies," these proceedings EPAC08, **TUPP061** (2008)
- [8] Calatroni, S. *et al.*, "Design Aspects of the RF Contacts for the LHC Beam Vacuum Interconnects," Proceedings PAC01 (2001)
- [9] Calatroni, S. *et al.*, "RF contacts for the LHC Collimators," Nucl. Instrum. Meth. A **566**, 205 (2006)