

DEVELOPMENT OF NON-DESTRUCTIVE BEAM CURRENT MEASUREMENT FOR THE iTHEMBA LABS CYCLOTRONS

Z. Kormány, ATOMKI, P.O. Box 51, H-4001 Debrecen, Hungary

K. Juhász, Faculty of Informatics, University of Debrecen, Hungary

J.L. Conradie, J.L.G. Delsink, D.T. Fourie, J.V. Pilcher, P.F. Rohwer, iThemba LABS, P.O. Box 722, Somerset West 7130, South Africa

Abstract

Transporting high-intensity proton beams at iThemba LABS requires non-destructive beam diagnostics. Different methods were considered for non-destructive beam current measurement. The aimed accuracy of the measurement is a few percent for beam intensities above 10 μ A. A system based on real-time processing of signals from capacitive probes in the time domain was built and tested successfully.

SSC provides important feedback about settings of the SSC. Another position where non-destructive intensity measurement is essential is at the new vertical beam line target station. The construction of this high beam power target does not facilitate direct current measurement, since the target itself is electrically grounded. The target current can therefore only be measured non-destructively. Capacitive probes and digital signal processing provide the cheapest solution to non-destructive current measurement.

INTRODUCTION

The K200 separated-sector cyclotron (SSC) and its two K8 solid-pole injector cyclotrons at iThemba LABS [1], accelerate beams of light and heavy ions as well as polarized protons for nuclear physics research, neutron therapy, proton therapy and radioisotope production. A significant share of the total beam time is used for high-intensity 66 MeV proton beam irradiations. Flat-topping systems [2] have been put into operation in the light-ion injector cyclotron (SPC1) and the SSC to increase the intensity of the 66 MeV proton beam for radioisotope production to 250 μ A. Having such a high power beam in the beam lines of the accelerators requires advanced beam diagnostic equipment since a relatively small percentage beam loss can cause severe damage and activation in the cyclotrons and beam lines. Non-destructive beam diagnostic equipment is therefore required for beam tuning and to allow continuous monitoring of the high-intensity beams.

NON-DESTRUCTIVE BEAM DIAGNOSTICS

During recent years significant efforts have been made at iThemba LABS to develop non-destructive beam diagnostic equipment. First a non-destructive beam position monitoring (BPM) system was developed and put into operation [3]. Based on the very positive operating experience the system has recently been extended. The nineteen BPMs that have been installed in the injection and the high-energy beam lines of the SSC have become indispensable diagnostic tools for medium- and high-intensity operation. Ionisation chambers mounted around the beam pipes are used as stray-beam detectors.

In addition to beam position data along the transport lines, beam intensity is another very important parameter to be monitored continuously during target bombardment at high intensities. For example, continuous comparison of the beam currents injected into and extracted from the

THE CAPACITIVE PROBES

The capacitive probes, of which a drawing is shown in Fig. 1, have to fit in the available space inside the existing diagnostic chambers and use available flanges for feedthroughs, without remachining of the chambers. This limits the length of a probe inside the shortest diagnostic vacuum chamber to 58 mm, with allowance for existing diagnostic elements in the chamber. The inner diameter has to be larger than 100 mm to prevent interception of beam and the outer diameter smaller than 150 mm to allow installation through one of the round ports through which the beam enters or leaves the chamber. Contact fingers on the copper housing of the probe are pushed open and pressed against the inside of the vacuum chamber port over its full circumference by turning a single nut on an internal clamp. Inductance in the support structure of the probe is thereby practically eliminated. A standard design suitable for all the beam lines and diagnostic chambers has been used. A characteristic impedance of 100 Ω could not be used due to the restrictions on the available space. The peak amplitude of

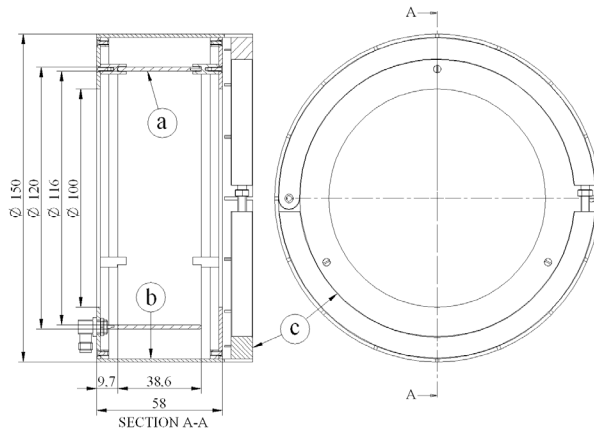

Figure 1: A capacitive probe showing the inner conductor, a, the outer conductor, b, and the clamp, c.

the bipolar beam pulses on the oscilloscope with 50 ohm input impedance is 50 mV for a beam intensity of 100 μA in the high-energy beam lines.

CURRENT MEASUREMENT WITH A LOCK-IN AMPLIFIER

The capacitive probes deliver high-frequency signals consisting of a train of about 2 ns long pulses, which are induced on the probe by individual beam bunches. The first set-up applied a Stanford Research Systems Model SR488 RF lock-in amplifier to analyze the signal from a probe in the injection beam line. The lock-in amplifier can measure the amplitude and phase values of any frequency component of a signal equal to the frequency of the connected reference signal. Since the probe signal can contain significant first harmonic pickup from the RF-systems, higher harmonic components were examined.

Extensive tests were carried out over a long period of time. The beam intensity was varied over a wide range while the amplitude of the second harmonic signal component was measured. The results of a series of measurements are shown in Fig.2.

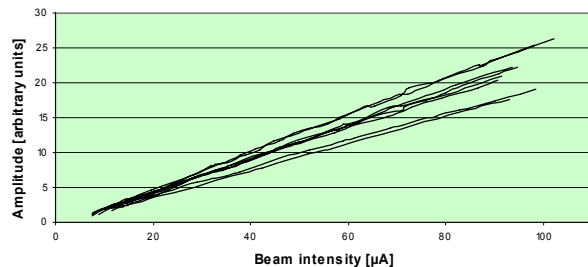

Figure 2: Measured dependence of the second harmonic component of a capacitive probe signal on the beam intensity.

Though proportionality between the amplitude of the second harmonic component and beam current is generally good, the method cannot provide the required accuracy of a few percent for intensity measurement. There are too large deviations in the slope of the lines, that at times cause error values as high as 30%. The reason for this can be understood with a closer look at the operation of the cyclotrons at iThemba LABS. Both in SPC1 and in the transfer beam line between SPC1 and SSC there are devices, such as slits and rebunchers that affect the longitudinal size of the beam bunches. The amplitude distribution of the discrete Fourier components of a periodical pulse train signal depends on the length of the pulses. A change in the bunch length consequently causes a change in the amplitude of any harmonic signal component. One can therefore measure different amplitudes for a given harmonic component at a fixed beam intensity.

TESTING A NEW METHOD

If the pulse length of the pick-up signal varies it is not sufficient to calculate the total intensity from just one harmonic component. Evaluation of the full signal is

necessary. The most straightforward method is to calculate the second integral of a pulse, because it has a close relation to the total amount of charge in the bunch passing through the pick-up. A new arrangement was built to test this method, using a Tektronix TDS5052 digital storage oscilloscope with a bandwidth of 500 MHz, to digitize the pick-up signal. The measured waveforms were read into a program, which applied a sophisticated signal-processing algorithm to extract a usable value for the intensity measurement. First the signal was cleaned from RF pickup and then the exact beginning and end of the individual pulses were determined. The pulse signal was integrated twice between its start and end points, and the resultant values averaged over a period of time. Fig. 3 shows the results of long term experiments with this method, which is clearly superior to the previous one. Both the linearity and the stability of the dependence between the calculated second integral and beam intensity values are good and it makes the method appropriate for current measurements with the expected accuracy.

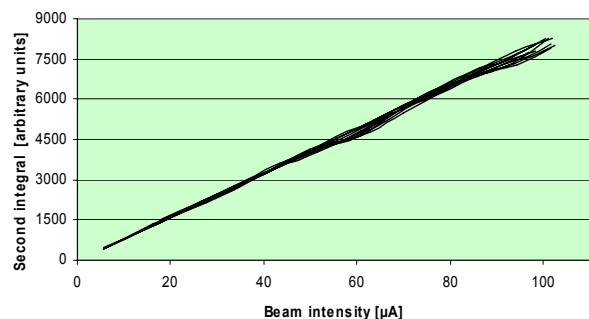

Figure 3: Calculated second integral of the beam pulses versus the beam intensity.

FINAL SYSTEM

The number of particles in individual beam bunches can vary by an order of magnitude with a frequency of about one MHz due to plasma oscillations in the PIG ion source. To achieve a reasonably stable dc current value a significant amount of averaging is necessary. At the same time fast response is required, i.e. any change in beam intensity should be reflected in the calculated value without undue delay. Reading waveforms from the TDS5052 oscilloscope was too slow to achieve these goals and the data throughput from the analog to digital converter had to be increased.

The final system uses a CompuScope 85G PCI-bus based oscilloscope card, which can perform analog to digital conversions at a rate of $5 \cdot 10^9$ samples per second with 8-bit resolution. It has two simultaneous input channels with an internal memory capable of storing digitized values for each. Capture repeat rates as high as 50 Hz can be obtained with the card installed in a PC.

In the case of a 66 MeV proton beam, for which the main radio frequency is 16.37 MHz, the card can digitize and store in its internal memory a time slice of the probe signal as long as about 32 RF periods in one shot. Due to the fact that the instabilities have a much lower

frequency, these signal periods are similar and cannot be effectively used for averaging. Instead, just one period is taken from every data capture and 200 successive captures are used to calculate the average waveform. The measured cycle time for this process is approximately 2 s. The second integral of the averaged pulse is then calculated and further smoothed by applying a fast software filter algorithm [4]. Four hundred points of the calculated integrals are filtered to extract the final value. This value is then converted to beam intensity using the RF-frequency of the cyclotron and a measured form factor of the capacitive pick-up.

The digitized signal of the capacitive pick-up (upper curve) together with the cleaned average waveform (lower curve) at beam intensity of about 11 μA can be seen in Fig. 4. The extent of the beam pulse could be determined precisely from the latter one and the beam current was properly calculated.

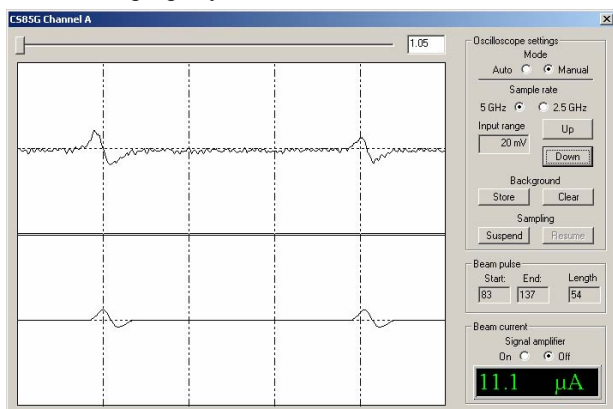

Figure 4: Digitized pick-up signal above and cleaned average waveform below.

The two input channels of the oscilloscope card allow simultaneous measurement of beam intensity at two different locations. The capacitive probes are directly connected to the inputs of the card without using a signal amplifier. With such an arrangement the low-current sensitivity threshold of the system for 66 MeV proton beam is at about 2 μA .

Fig. 5 shows statistics of beam intensity data measured simultaneously with this system, using a probe in the injection line, and with a Keithley 485 Pico ammeter on a Faraday cup just behind it for a beam intensity of approximately 10 μA . Calculated standard deviation values are also displayed for both measurement methods. The standard deviation of the non-destructive measurement is larger than that of the measurement with the Faraday cup because the intensity values are calculated from a limited number of waveform samples. However, it does not differ much from the value of the Keithley-measurement, thereby showing that the larger part of the inaccuracy is due to beam intensity fluctuations. After separating the standard deviation of the latter, a value of about 172 nA is obtained for the method itself, showing that the expected accuracy for the intensity measurement has been achieved.

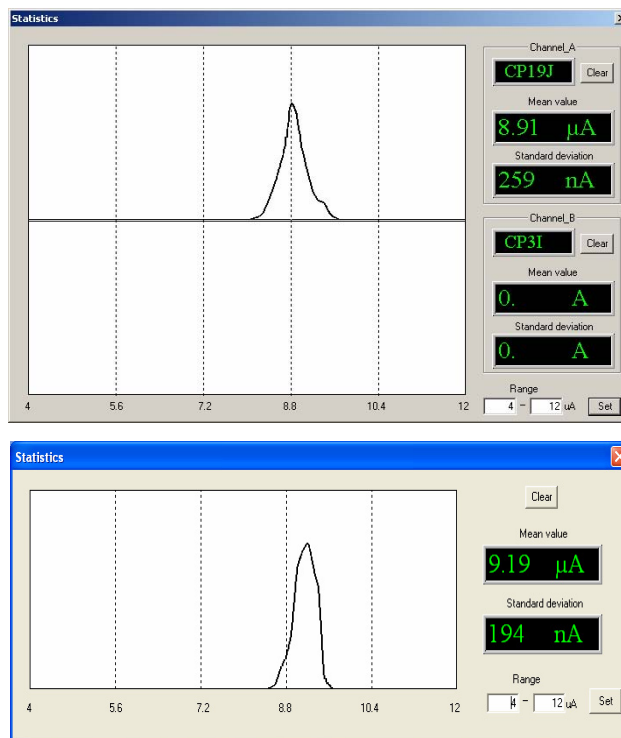

Figure 5: Distribution of the simultaneously measured beam current with a capacitive probe, above, and with a Faraday cup, below.

CONCLUSIONS

Modern waveform digitizers open up new ways for beam diagnostics of cyclotrons. When installed in a fast computer, they can provide sufficient data throughput for complete evaluation of high-frequency signals in the time domain. This allows the calculation of beam intensity from the digitized waveform from capacitive probes, installed in cyclotron beam lines. The signal processing provides accurately-calculated current values in spite of micro-instabilities in the beam.

REFERENCES

- [1] J.L. Conrardie et al., "Improvements to the iThemba LABS Cyclotron Facilities", Cyclotrons'2007, Catania, October 2007, to be published.
- [2] J.G. de Villiers et al., "A Flat-topping System for the Separated Sector Cyclotron at iThemba LABS", Cyclotrons'2004, Tokyo, October 2004, p. 344.
- [3] J. Dietrich et al, Operational Experience with Beam Alignment and Monitoring Using Non-destructive Beam Position Monitors in the Cyclotron Beam Lines at iThemba LABS", DIPAC'2005, Lyon, June 2005, p. 96.
- [4] B. Dvorak, "Software Filter Boosts Signal Measurement Stability, Precision", Electronic Design, Vol. 51 (2003), No. 3, p. 60.