

STATUS OF THE HIGH POWER, SOLID-STATE RF AMPLIFIER DEVELOPMENT AT LABORATORI NAZIONALI DI LEGNARO

F. Scarpa, D. Zenere, A. Facco, INFN - Laboratori Nazionali di Legnaro.

Abstract

The development of high power, unconditionally stable solid-state amplifiers for superconducting low-beta cavities, performed at Laboratori Nazionali di Legnaro in the framework of the EURISOL Design Study and in collaboration with Synchrotron Soleil [1], has led to the construction and testing of two newly designed 10 kW units that can be used both individually or coupled together to obtain a 20 kW source. This family of amplifiers, based on parallel assemblies of 300 W modules equipped with mosfets and individual circulators, gives the possibility of operating in any matching conditions and also, at a reduced power, in case of failure of one mosfet. Characteristics of amplifiers and high power combiner will be described, and their performance and test results will be reported.

THE 10 KW AMPLIFIER

This 352 MHz amplifier uses home-designed 300 W solid-state modules already described in a previous publication [2]. Its block diagram can be seen in Fig. 1.

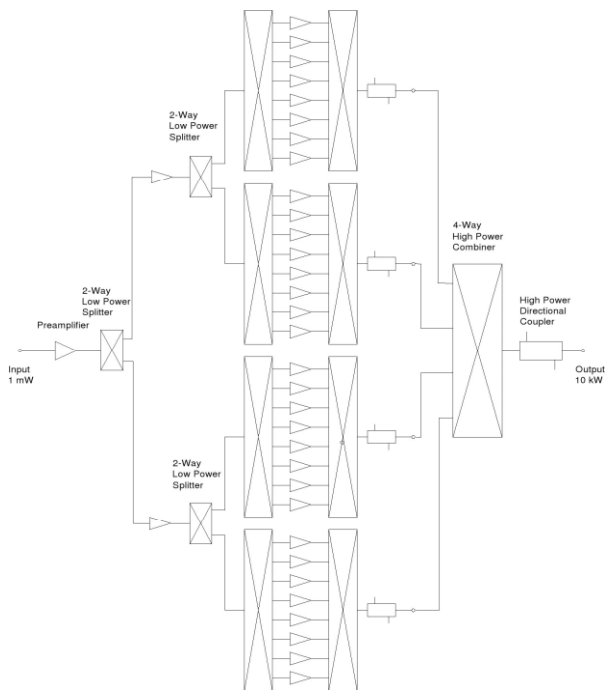

Figure 1: Block diagram of the 10 kW amplifier.

This diagram is slightly different from the one of earlier versions in the choice of the mosfet, which is now the Semelab DMD1029A [2]. Its higher power gain made it possible to save 2 modules in the driver stage.

Each module, except for the preamplifier, is still equipped with a 300 W circulator and a power

termination in order to manage the reflected power coming from the superconducting cavities. All modules were assembled by an external Broadcasting Company, following our design and according our specifications.

The amplifier was housed inside a rack cabinet 0.6 m wide, 1 m deep and 2 m tall. The cabinet is equipped with four heavy-load wheels with brakes to make displacement easier (Fig. 2). The total weight is 430 kg.



Figure 2: Picture of the amplifier, front and rear.

The amplifier can be operated both from a 6" Touch Panel Computer, located in the front panel together with all others diagnostic lamps, and from a remote computer connected through Ethernet link. The low-power RF signal connections, as well as the external interlock and Ethernet connections, are located in the front panel below the touch-screen. The high power EIA 3" 1/8 output RF connector is located in the back of the amplifier, which is left open to allow an easy extraction of the hot air flow coming from the AD-DC power supplies. A stainless steel grid has been mounted for operator's protection.

THE CONTROL SYSTEM

The amplifier control system allows checking its status continuously. The National Instruments Compact Field Point 2100 controller is used, with the following configuration:

- N. 5 modules with 16 channels, 16 bit ADC for a total number of 80 channels.
- N. 1 module with 16 digital inputs.
- N. 1 module with 16 digital outputs.
- N. 1 module with 8 thermocouple channels.

This device allows quick and easy programming by using the LabVIEW development system. Many parameters, like RF power, DC supply currents of all modules and temperatures, as well as digital signals, are acquired, measured and used by the control software to generate warnings, alarm indications and safe shut-down procedures in case of failure. All collected data are displayed in the local 6” Touch Panel Computer and also in the remote computers connected via Ethernet link, where they can be optionally saved.

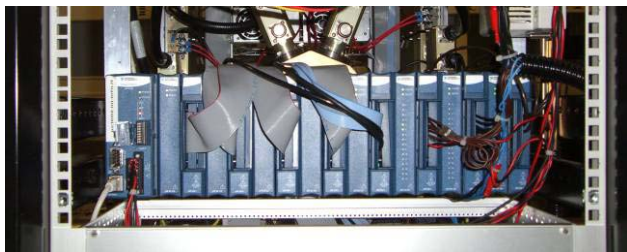

Figure 3: The embedded controller

The software, written in LabVIEW, is based on the client-server architecture and is composed by the following parts:

- The server program, running in the Field Point controller.
- A client program, running in the local Touch Panel Computer (TPC).
- A different client program, running optionally in remote computers.

The server program starts automatically at the amplifier switch-on and runs in continuous loop until the electrical power is on. Its tasks are: switching on and off the amplifier, acquiring both analogue (DC currents, RF power values and temperatures) and digital signals, measuring and analyzing the acquired signals, generating and managing the alarms, communicating via Ethernet link using the TCP-IP protocol with both local and remote clients.

The local client program, running in the local TPC, allows the control of the amplifier in local mode; it is always connected to the server, and it doesn't inhibit the connection of remote clients.

The remote client programs receive the data from the server and display this large amount of data in different pages on the screen. Two versions of the remote client have been written: the first one has the possibility to set controls and parameters of the amplifier; the second one allows only reading. Both allow data saving.

TESTS

As usual, several tests have been done after the completion of the amplifier construction.

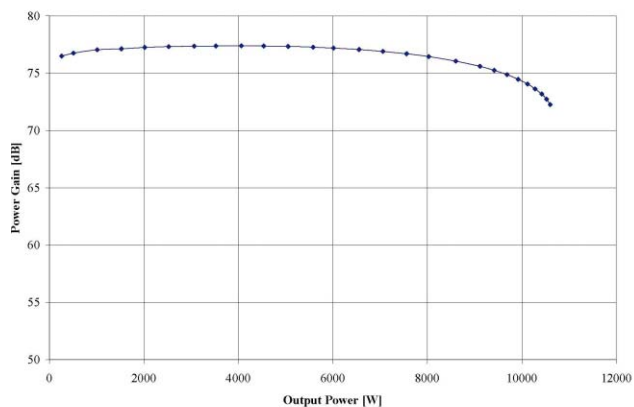

Figure 4: Power sweep test.

The power sweep test shown in Fig. 4 refers to the amplifier in its final configuration; as it can be seen, the power level of 10 kW can be reached with a moderate gain drop of about 3 dB with respect to its maximum value (77.4 dB at 4.5 kW). Above 10 kW the gain drops much faster, as an effect of the built-in power limiter. The maximum safe operation point in CW mode has been established to be 8.8 kW average, while the absolute maximum level, that should be maintained only for a short time intervals, is 10 kW. The protection system switches off the amplifier very quickly when this level is overcome, as for example in case of an accidental overdriving.

These power limits have been established after an analysis of the DC supply currents of all the RF amplifier modules, acquired by the control system and recorded in a remote computer. The histograms of the 64 average DC power supply currents at three output power levels are shown in Fig. 5.

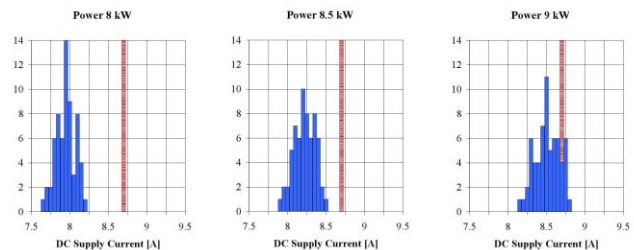

Figure 5: Histograms of the DC supply currents

In order to avoid damage to the RF modules, each DC current must not exceed the value of 8.7 A for CW operation and 9.3 A for short periods; the first current limit is indicated in the graphs above.

In Fig. 6 is shown the result of the first test 14 days long in load matching condition at 8 kW.

The amplifier was reliable and stable during operation. A small gain reduction appeared at the beginning of the test due to conditioning, and stabilization occurred after 7 days. The gain reduction at the end of the test was of 0.4 dB confirming the need of setting maximum power limits for long term operation.

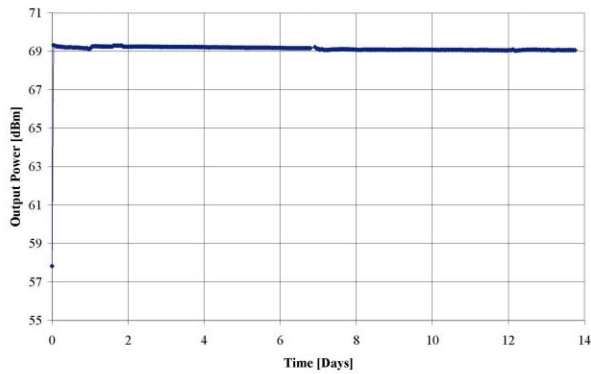

Figure 6: First long test.

The second, 20 days long test was done in order to check the behaviour of the amplifier in full reflection condition by connecting a short-circuit flange at the high power RF output connector. The test results can be seen in Fig. 7.

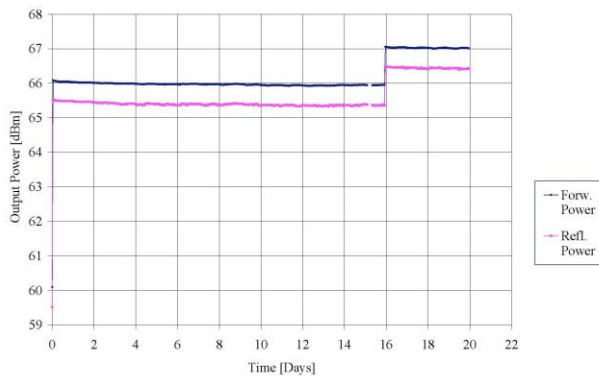

Figure 7: Second long test.

The power used for this test was 4 kW (about the half maximum power for CW operation) for 16 days, increased to 5 kW for the last 4 days since no problem has been detected.

THE HIGH POWER COMBINER

In order to increase the output power, two or more 10 kW units can be used together by means of a high power rf combiner. In our case 2 units will be connected to obtain 20 kW. The required components are a 2-way, low power splitter at input and a 2-way, high power combiner at output. The block diagram of this assembly is shown in Fig. 8.

Since in the input stage a very low power level is present, any suitable commercial 2-way splitter can be used. The High power 2-way combiner, on the other hand, must be carefully designed in order to obtain very good matching and high coupling efficiency.

The EM simulation software CST Microwave Studio has been used to design and simulate this component; the resulting structure can be seen in Fig. 9.

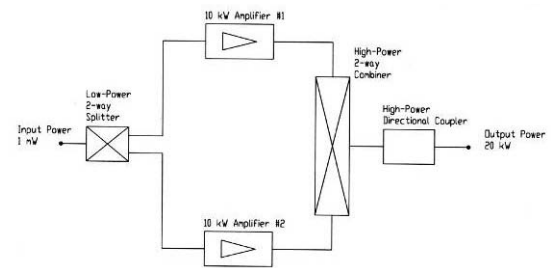

Figure 8: Block diagram of the 20 kW assembly

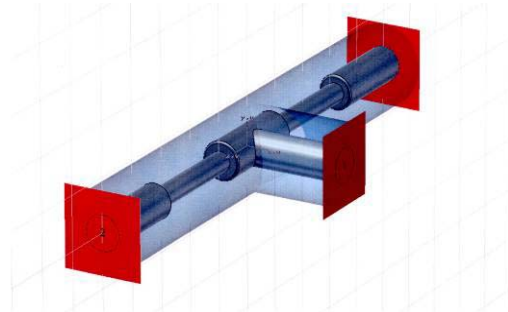

Figure 9: The simulated High Power Combiner.

The simulated RF matching characteristics can be seen in Fig. 10.

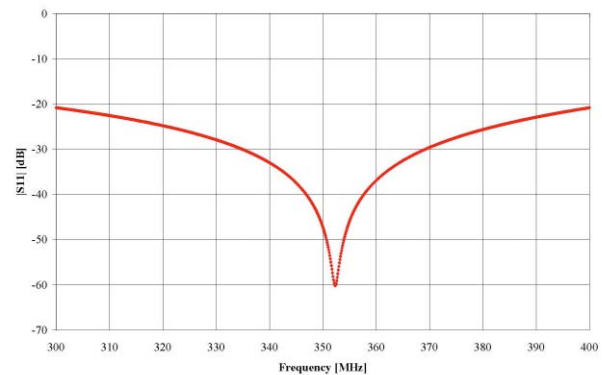

Figure 10: S11 Characteristic of the simulated Combiner.

This combiner is now ready for construction. The 20 kW assembly will be used for high power coupler conditioning and for superconducting cavity testing in the EURISOL Task 8 framework [3].

REFERENCES

- [1] F. Scarpa, et al, "A 2.5 kW, LOW COST 352 MHz SOLID-STATE AMPLIFIER FOR CW AND PULSED OPERATION", Proceedings of EPAC 2002, Paris, France, p. 2314
- [2] F. Scarpa, A. Facco, D. Zenere, "HIGH POWER, SOLID-STATE RF AMPLIFIERS DEVELOPMENT FOR THE EURISOL PROTON DRIVER", Proceedings of EPAC 2006, Edinburgh, Scotland, p. 1394
- [3] Web page: <http://www.eurisol.org/site01/index.php>