

# INFLUENCE OF BEAM TUBE OBSTACLES ON THE EMITTANCE OF THE PITZ PHOTOINJECTOR\*

S. Setzer, W. Ackermann, S. Schnepf, T. Weiland  
 TEMF, Technische Universität Darmstadt, D-64289 Darmstadt, Germany

## Abstract

For detailed analysis of space charge dominated beams inside an RF Photoinjector PIC-Codes like CST MAFIA TS2/3™ can be used. While the interaction of particles with the surrounding geometries are taken into account, the applicability of such codes is restricted due to simulation time and memory consumption as well as by numerical noise. Therefore, only smaller sections of the whole injector can be calculated. On the other hand codes like ASTRA can be used to simulate the whole injector but no interaction between bunch and geometry is included. To make use of the individual advantages of each code described above an interface for bidirectional bunch exchange between the two programs has been implemented. This approach allows for applying the right simulation method depending on the physical effects under investigation. To demonstrate the importance of such an approach the results of detailed numerical studies of the impact of beam tube obstacles like the laser mirror on the achievable emittance of the PITZ RF Photoinjector further downstream will be presented. PITZ is the photo injector test facility at DESY Zeuthen [1].

## INTRODUCTION

For the successful operation of future linear colliders as well as free electron lasers based on the SASE principle the generation of very low emittance beams with high bunch charges is of fundamental importance. To achieve this goal, laser driver RF guns providing high accelerating fields on the cathode are used. To further reduce the emittance, a solenoid based emittance compensation scheme is commonly used [2]. In order to investigate the behaviour of the space charge dominated emittance growth during acceleration inside the RF gun PIC-codes like MAFIA TS3 [3] have been used successfully. This code does not only calculate the space charge forces of the beam itself, it also takes into account the interaction of the charged particles with the surrounding structure. While this method gives very accurate results, it is limited in its application to short sections of the injector due to memory consumption, computation time and numerical noise. On the other hand simulation tools like ASTRA [4] are capable of calculating large parts of the accelerator but no interaction between the particles and the

surrounding structure is taken into account. When it comes to the generation of beams with very low emittance, the effects of beam tube obstacles like a diagnostic cross or the laser mirror on the emittance cannot be neglected anymore. To make use of the advantages of each simulation code an bidirectional interface between MAFIA TS3 and ASTRA has been developed, allowing the exchange of particle information between the two codes. With the help of this interface it is possible to make use of the advantages of each simulation method.

## SIMULATION RESULTS

The bidirectional interface between MAFIA TS3 and ASTRA has been applied to the PITZ injector shown in Fig. 1.

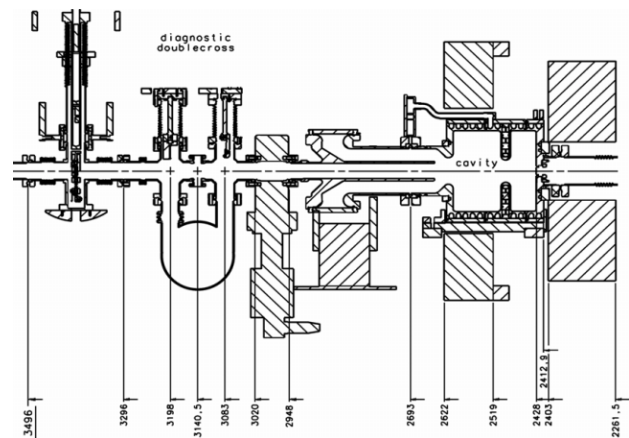

Fig. 1: Sketch of the PITZ setup.

ASTRA was used for the simulation of the first part up to the diagnostic double-cross. At this location all particle information is handed over to a subsequent MAFIA TS3 simulation. At the end of the diagnostic double-cross the particles are once again converted back to the ASTRA format and the beam dynamics up to the location of the emittance minimum is calculated. The main parameters of the injector are shown in Table 1.

## Validation of the interface

In order to validate the correct implementation of the interface the double-cross located at about 60 cm downstream of the cathode was substituted by an homogeneous drift tube. The results of the validation run are shown in Fig. 2.

\* S. Setzer: Work supported by DFG under contract GRK 410/3  
 W. Ackermann: Work supported by DESY Hamburg  
 S. Schnepf: Work supported by HGF under contract VH-FZ-005  
 setzer@temf.tu-darmstadt.de

Table 1: Parameters used for the simulation

Laser pulse length	20 ps (FWHM)
Laser rise/fall time	5 ps
Laser spot size	0.5 mm (x,y RMS)
Bunch charge	1 nC
Accelerating field on cathode	42 MV/m
RF-Phase	33°
Max. fluxdens. of the solenoid	175 mT
Location of the maximum	27.5 cm

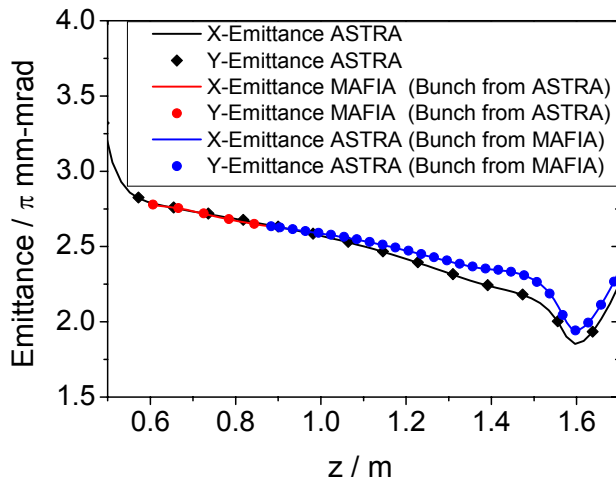

Fig. 2: Transverse Emittance calculated by Astra and the corresponding results obtained by using the interface.

It can be seen in Fig. 2 the results are in very good agreement. As expected for a rotational symmetric structure, the x and y emittances are equal. The small emittance growth at the minimum located 1.6 m behind the cathode of about  $0.09 \pi$ -mm-mrad compared to a single ASTRA run is caused by the different space charge methods used by the individual codes resulting in a quite small deviation of the phase space distributions.

### Influence of the laser mirror

After the successful test of the interface the real geometry consisting of the diagnostic double-cross with the laser mirror installed has been investigated. The mirror itself has been modelled using CST MicrowaveStudio™ [2]. Afterwards the individual shapes were imported into MAFIA and introduced to the meshing process. A drawing of the laser mirror as well as the corresponding MicrowaveStudio model are shown in Fig. 3. In a real accelerator it is usually quite difficult to ensure that the beam has no offset with respect to the axis. Therefore, besides the influence of the laser mirror itself on the transverse beam emittance also its dependency on the beam offset has been investigated. Obviously, a beam offset in the direction of the laser mirror is quite worse than one in the perpendicular direction. Therefore, only results for beam offsets on the x-direction are presented.

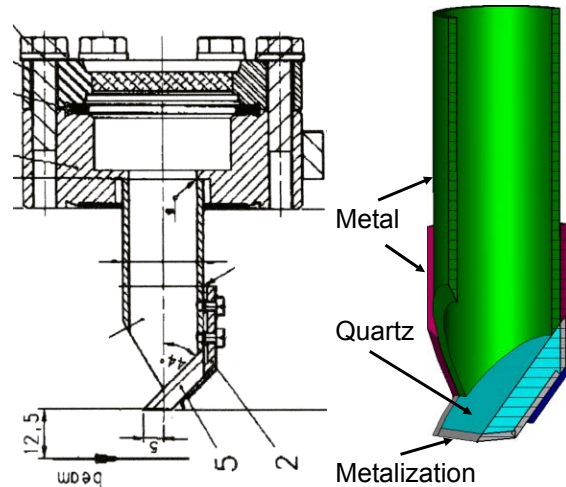

Fig. 3: Drawing of the laser mirror (left) and corresponding MicrowaveStudio model used for the simulations (right).

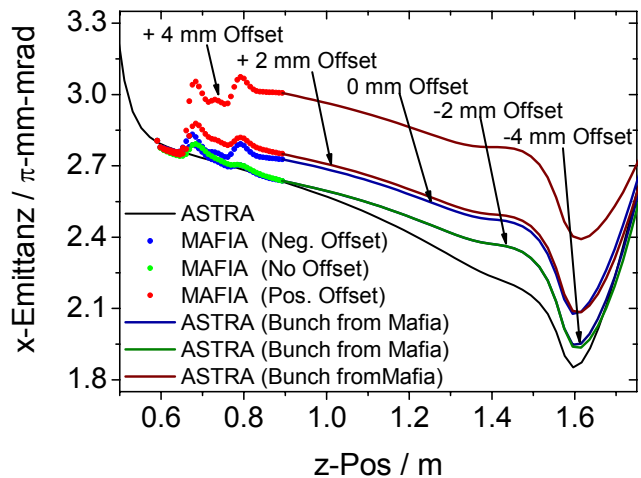

Fig. 4: Dependency of the x-emittance on the beam offset in the direction of the laser mirror. The black line represents the results predicted by a single ASTRA run starting at the cathode without using the interface.

Fig. 4 and Fig. 5 depicts the dependency of the x and y-emittance on the beam offsets in the range of  $\pm 4$  mm. The resulting emittance growth caused by the laser mirror is summarized in Table 2.

Table 2: Emittance growth in the x and y plane at the local emittance minimum (at 1.6 m) for different beam offsets.

Beam Offset	x-emit. growth	y-emit. growth
+4 mm	0.45 $\pi$ -mm-mrad	0.17 $\pi$ -mm-mrad
+2 mm	0.15 $\pi$ -mm-mrad	0.06 $\pi$ -mm-mrad
0 mm	0.0 $\pi$ -mm-mrad	0.0 $\pi$ -mm-mrad
-2 mm	0.0 $\pi$ -mm-mrad	0.0 $\pi$ -mm-mrad
-4 mm	0.15 $\pi$ -mm-mrad	0.06 $\pi$ -mm-mrad

## REFERENCES

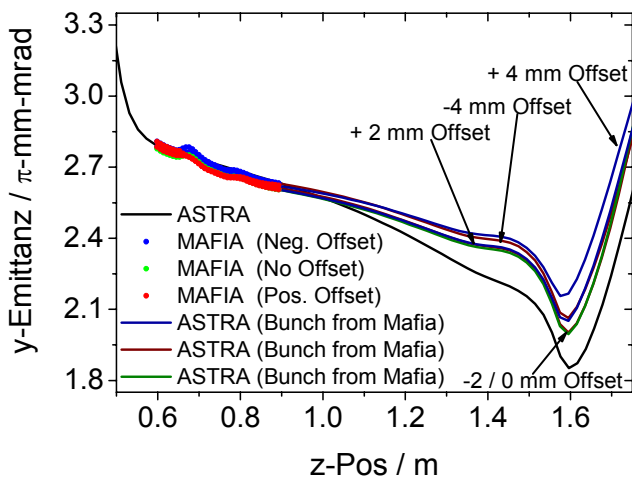

- [1] F. Stephan for the PITZ collaboration: "First measurements at the photo injector test facility at DESY Zeuthen", Proceedings of the EPAC 2002
- [2] B. E. Carlsten: "New Photoelectric Injector Design for the Los Alamos National Laboratory XUV FEL Accelerator", Nucl. Instrum. Methods A 285, p313, 1989
- [3] CST GmbH, Bad Nauheimer Strasse 19, D-64289 Darmstadt, Germany
- [4] K. Flöttmann: "ASTRA user manual", [www.desy.de/~mpyflo/Astra\\_Dokumentation](http://www.desy.de/~mpyflo/Astra_Dokumentation)

Fig. 5: Dependency of the y-emittance on the beam offset in the direction of the laser mirror. The black line represents the results predicted by a single ASTRA run starting at the cathode without using the interface.

The emittance growth of a perfectly aligned beam caused by the laser mirror installed in the diagnostic double-cross is about  $0.09 \pi\text{-mm-mrad}$  in the x-plane and  $0.14 \pi\text{-mm-mrad}$  in the y-plane correspondingly compared to a complete ASTRA run starting at the cathode. If the beam passes very close to the mirror (+4 mm offset), the x-emittance is significantly increased by  $0.45 \pi\text{-mm-mrad}$ .

## CONCLUSIONS

In this paper the effect of beam tube obstacles like the laser mirror on the achievable minimum beam emittance has been investigated. This was done with the help of an bidirectional interface allowing the exchange of particle information between ASTRA and MAFIA TS3. It was shown that for a perfectly aligned beam the emittance growth caused by the laser mirror installed in the diagnostic double-cross is about  $0.09 \pi\text{-mm-mrad}$  in the x-plane and  $0.14 \pi\text{-mm-mrad}$  in the y-plane correspondingly compared to a complete ASTRA run starting at the cathode. If the beam has an offset of +4 mm in the direction of the laser mirror, the emittance growth in the x-plane is about  $0.45 \pi\text{-mm-mrad}$  ( $0.55 \pi\text{-mm-mrad}$  compared to the ASTRA results). Therefore, the effect of obstacles like the laser mirror cannot be neglected in a low emittance injector.