

GANIL AXIAL INJECTION DESIGN WITH AN ECR ION SOURCE

M.P. BOURGAREL, E. PLAWSKI\*, L. BEX, P. DI BERNARDO\*\*

GRAND ACCELERATEUR NATIONAL D'IONS LOURDS  
BP 5027 14021 CAEN CEDEX (France)

**SUMMARY.** The main features of the adaptation of an hyperboloid inflector to the central region of the injector cyclotron and the beam transmission are presented.

INTRODUCTION

The maximum energy of GANIL depends on the initial charge  $Z_1$ . Actually, GANIL is in operation with the first injector cyclotron <sup>1,2</sup> and an internal PIG ion source.

A 2nd injector, identical to the first one, has been planned in view of giving more flexibility to the machine operation. It is being assembled and is planned to be tested in October 84.

In order to increase the energies, mostly on the 80-to-170 mass range where the users' demand is strong, and also in order to get a more continuous working time than with the internal source, in addition to this one, an ECR <sup>3</sup> source will be incorporated to the 2nd injector.

Fig. 1 shows the energies that can be obtained from an initial charge  $Z_1$ . Limits are due to the maximum magnetic field and stripping efficiency. As seen from these curves, an ECR source is especially convenient to produce these charges (Ar<sup>6+</sup>, Kr<sup>10+</sup>, Xe<sup>13+</sup> ...) and to reach 90, 65 and 45 MeV/A respectively.

The construction of the ECR source (MINIMAFIOS) - identical to the SARA and KVI ones - has been undertaken in 1983 by R. Geller and his group at CEN-G. They have tested it successfully for N<sup>2+</sup> (320 eμA) and Ar<sup>6+</sup> (40 eμA) ; Kr and Xe will be measured soon. Emittances, expected to be < 150 π mm-mrad at 20 KV, were in fact recently measured to be 150 mm-mrad. The assembling on GANIL is planned for September and first tests in December.

A compact injection system has been designed last year to transport the ECR beam to the 2nd injector, over a distance about 6 m and it is partly under construction. The axial injection operation is expected in June 1985.

This paper presents the main features of the resulting design :

a) the system will be operating with an external source as well as with an internal source. Thus, the requirement is to conserve the central region that has been designed for the internal source to meet injector specifications (phase width and emittance), except for the puller which is removable.

b) the large turn separation (the radius of the first orbit is  $R_0 = 6.8$  cm) allows to choose a hyperboloid type inflector <sup>4</sup> for its exceptional optical properties, although it needs an off-axis injection.

c) the ion source can be located in the injector hall which is radiation-free : thus the beam handling system is short and it has been designed without too much sophistication : a totally achromatic version seems to be unjustified for the ECR beam characterized by a very small energy dispersion (30 ev/per charge). Therefore a version has been calculated, which is dispersive in the horizontal plane, and achromatic in the vertical plane to allow an RF buncher.

d) users' experience showed the disadvantage of analyzing just after the puller, due to the ECR fringing field effects on the analyzing magnet. So we have chosen to refocus the beam with a solenoid.

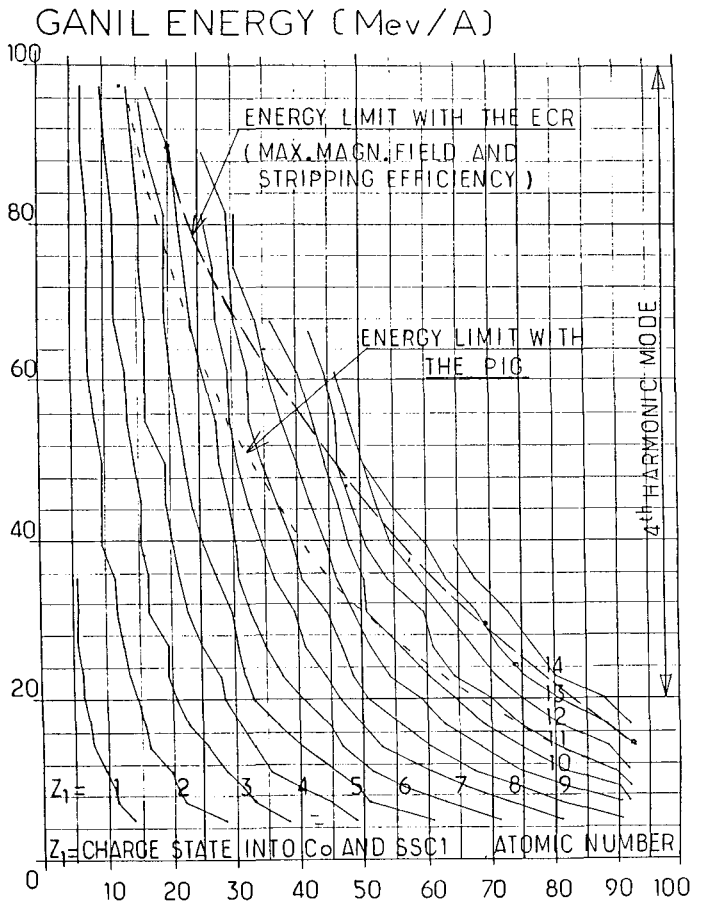

Fig. 1 - The GANIL energy increase with the ECR source.

\* Instytut Problemow Jadrowych, Swierk, Poland.

\*\* Facolta di Fisica. Corso Italia 53-95100 Catania Italia.

Beam matching in the central region

1. Energy adaptation

The actual central region has been designed for an internal ion source, operation on the 4th harmonic and accurate values of energy and phase at the puller entrance, to obtain a well centered beam (Position  $P_0$  on the Fig.2).

Calculations show that this energy after the first gap - 97% of the maximum energy  $ZV$  - will be conserved with the axially injected beam if this gap width is matched to the injection energy. Central phase has also to be adjusted to another value, so that the puller position  $P_0$  has to be shifted.

Fig2. shows the reference particle trajectory and the geometry of the central region with the new puller entrance  $P_4$  which matches the beam leaving the inflector to the fixed orbit pattern of the cyclotron : the injection energy is  $0,217 \times$  maximum energy  $ZV$ , the accelerating gap width  $P_3P_4$  is 3.1 cm, the central phase is  $-76^\circ$  at  $P_3$  and  $71^\circ$  at  $P_4$  ; the starting phase width can be  $30^\circ$  at  $P_3$  with a small phase compression effect giving  $17^\circ$  at  $P_4$  and with an energy dispersion of 2%.

2. Inflector parameters

The injection energy determines the hyperbolic inflector parameters given in Table 1 and on Fig3. The choice of the magnetic radius  $R_{mag} = 3.25$  cm is a compromise between a voltage range of 8 - 20 kV on the ECR source and the inflector height compatible with the magnet gap. The inflector position (entrance  $P_1$  and exit  $P_2$ ) is also the result of a compromise between RF voltage holding conditions and an off-axis limited to 4 cm.

3. Beam matching conditions

General orbit code calculations have been made<sup>2</sup> with the internal ion source and have allowed to define the injector acceptance (Fig4). In the  $(r, \dot{r}, \phi)$  space, the criterium to get the matching area is to select the particles which fill the specifications on ejected beam qualities given in table 1 and needed for the injection in the SSC1. In the  $(z, \dot{z}, \phi)$  space, in addition to these conditions the beam height is limited to 30mm.

As seen from the curves of Fig4. the ECR source emittances, expected to be  $< 150 \pi$  mm-mrad, will be completely included into the acceptance areas.

So phase space areas are fixed at the exit of the inflector.

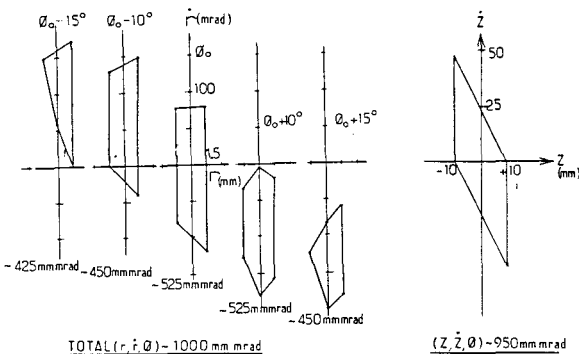

Fig4. The horizontal et vertical injector acceptances at  $P_3$  (inj. energy) to meet beam specifications. The central phase  $\phi_0$  is  $-76^\circ$  and the starting phase width is  $30^\circ$ .

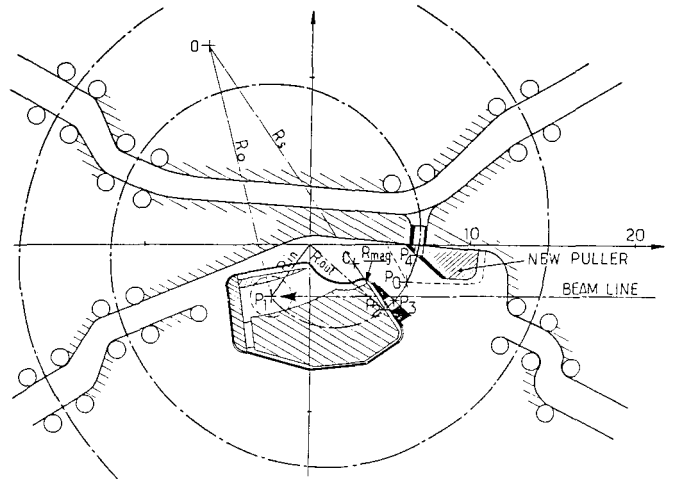

Fig2. Central region on the 4th harmonic with the reference trajectory starting from the hyperboloid inflector.

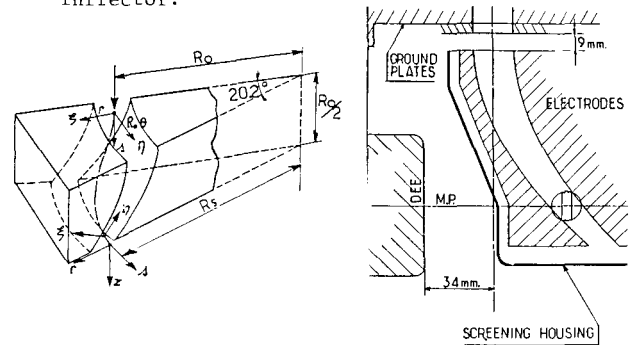

Fig3. The hyperboloid inflector parameters and electrical considerations.

Table I  
Fixed cyclotron parameters for the Axial injection

R.F frequency range (MHz)	6.5 - 14
Harmonic mode	4
Magnetic range (T)	0.8 - 1.7
Max. Dee Voltage V (kV)	90
Max. Ratio Z/A	0.136
First orbit radius (cm)	6.8
Free gap (cm)	18.

Inflector parameters

Max. ECR source voltage (kV)	20
Magnetic radius $R_{MAG}$ (cm)	3.25
Injection energy / $ZV$ ratio	0.2177
Radius $R_0$ (cm)	15.92
Radius $R_s$ (cm)	19.5
Height (cm)	7.96
Distance $P_1 P_2$ (cm)	7.14
Distance $P_1 C$ (cm)	5.65
$R_{in}$ radius (cm)	4.
$R_{out}$ radius (cm)	6.25
Distance between electrodes (cm)	2.
Max. Voltage on electrodes (kV)	$\pm 5$

Specifications on ejected beam qualities

Phase width (degrees)	$< 15^\circ$
Total energy dispersion	$< 1\%$
Emittance ( $\pi \times$ mm x mrad)	$< 45$

Beam transmission through the cyclotron magnet

Beam matching problems consist in going up-stream through the inflector and magnetic field of the cyclotron bore.

For this purpose, we used the following method :

- 1) The emittances are assumed matched in both directions (Fig5a).
- 2) The inflector is represented by its transfer matrix.
- 3) Since the field at the entrance opening of the magnet gap is a slowly varying function, this region is represented as a succession of a finite number of ideal solenoids. The values of the field in each small section are taken from the real field computed with Poisson program.
- 4) Adequate transmission through the axial hole is obtained with two solenoids, treated in a similar way by the matrix calculations.

Fig5. shows the emittances in  $(r, \dot{r}, r\theta, r\dot{\theta})$  and  $(z, \dot{z}, r, \dot{r})$  phase space at some successive points and coupling between the two planes.

In a first time currents and polarities of the two solenoids have been combined with fringe field of the magnet, so that spaces  $(r, \dot{r}$  and  $r\theta, r\dot{\theta})$ , uncoupled at the exit of the inflector, appear also uncoupled at the entrance of the yoke.

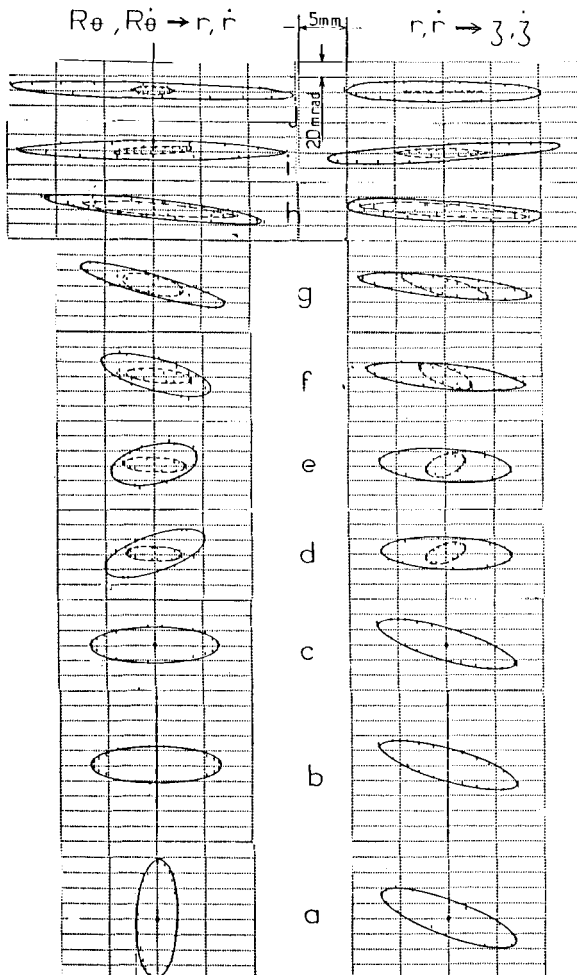

FIG 5 - phase space ellipses along the axial trajectory

Then design considerations led us to adopt a beam line injection, rotated by 15° with the inflector coordinate system. It has been possible to do this rotation with a slight adjustment of the two solenoids. The beam envelope and rotation obtained in the magnetic longitudinal field are also calculated with another program that computes trajectories by numerical integration of motion. Results are similar to matrix method.

Likewise, the beam envelope inside the inflector is computed with a special computer code because of the introduction of an optical coordinate system ( $\xi, \eta$ )

All these calculations show that with a smooth focusing, beam dimensions of  $\approx 18$  mm at the yoke entrance will be gradually reduced and the beam size between the inlet bore in the pole and inflector entrance will be always  $< 15$  mm. So (Fig 6) :

- the distance between the electrodes is  $d = 20$  mm
  - the bore diameter is 30 mm in the upper part of the pole and 20 mm in the lower one, with a shimming to compensate the perturbation. Thus a rapid rise of the magnetic field and homogenous field along the trajectories inside the inflector are obtained as seen from Fig 7.
- To minimize the first harmonic, a symmetrical bore has been added.
- the bore diameter in the yoke is 250 mm and the beam pipe diameter is 65 mm. This last value allows to expect a pressure of a few times  $10^{-4}$  mbar.
  - in spite of the off-axis, the two solenoids (65000 and 25000 AT) can be properly dimensionned.

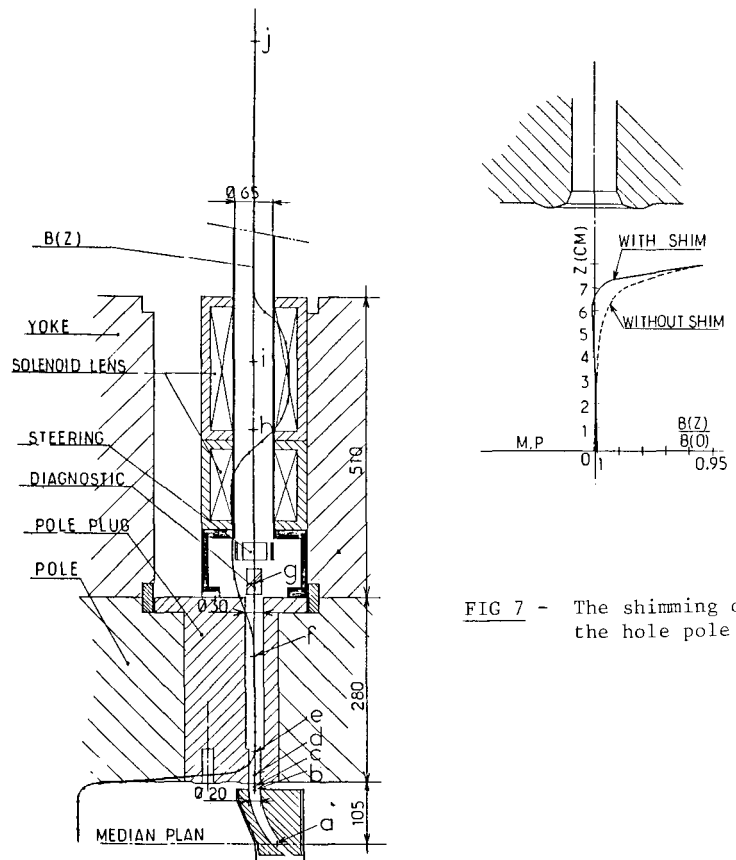

FIG 6 - Axial hole with focusing elements. The axial field  $B_z$  is plotted.

FIG 7 - The shimming of the hole pole

External beam transport system

Calculations were made using the program TRANSPORT. The adopted version (Fig 8) is dispersive in the horizontal plane and achromatic in the vertical plane. It consists of two principal sections :

The first one incorporates :

- 1) a solenoid to refocus the beam of the ECR source
- 2) a momentum analyzing magnet (102°) with a separating power of 1.5 cm/% dp/p with the object slit width of 8 mm.
- 3) Four magnetic quadrupoles to match the transverse space-phase to the yoke acceptance.
- 4) a RF buncher, not yet defined. Since the drift length in the cyclotron yoke is small (80 cm) it is necessary to place the buncher in the horizontal section. From this point on, the second section has to be achromatic.

The second section consists of a 90° vertical BROWN type achromatic bend.

Fig 9. shows the envelope calculated for a 150 π mm-mrad Ar<sup>6+</sup> beam, matched to the entrance of the yoke. Four beam profile monitors located before and after the two bends, measure the beam center shift and dimensions, that will allow to compute the experimental emittance and to adjust the adaptation. Besides the ECR source, the possibility of using the same beam transport line to inject beams delivered by a PIG source, has been investigated. A second entrance into the analyzing magnet has been provided with a 69°5 bend and 56 cm radius, which will not be described here.

References

1. M. P. Bourgarel and AL. - The GANIL injector design - 8th Int. Cycl. Conf. - 1978 p 1944
2. M. P. Bourgarel and AL. - Progress report and first operation of the GANIL injector - 9th Int. Cycl. Conf. 1981 - p 121
3. R. Geller and B. Jacquot - Nucl. Inst. and methods 184 (1981) p 293
4. R. W. Muller - Novel inflectors for cyclic accelerators Nucl. Inst. and Meth. 54 (1967) 29 - 41

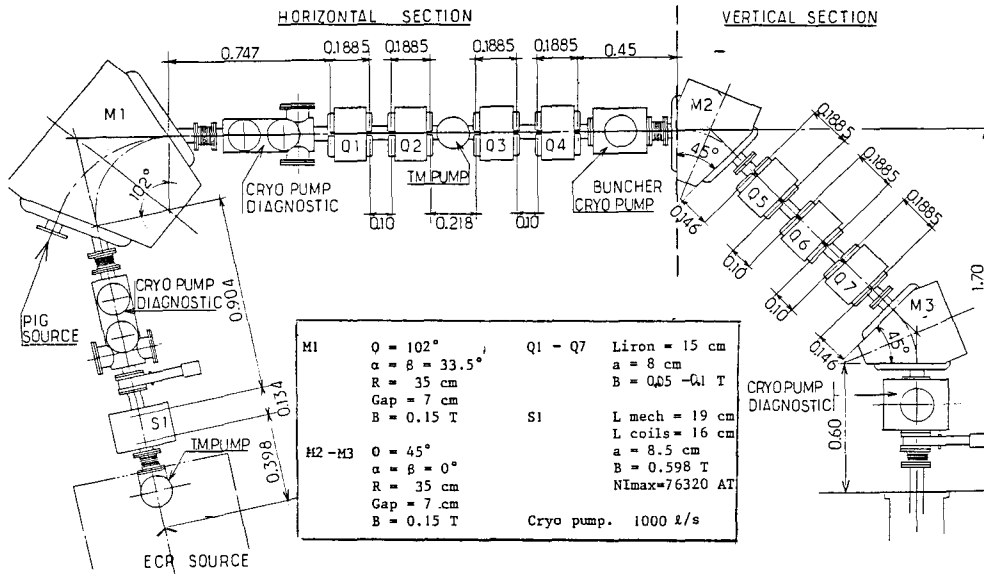

FIG 8 - Beam line proposal. The first section is horizontal above the cyclotron : analyse and focusing ; matching to the injector acceptance. The second section is vertical and achromatic.

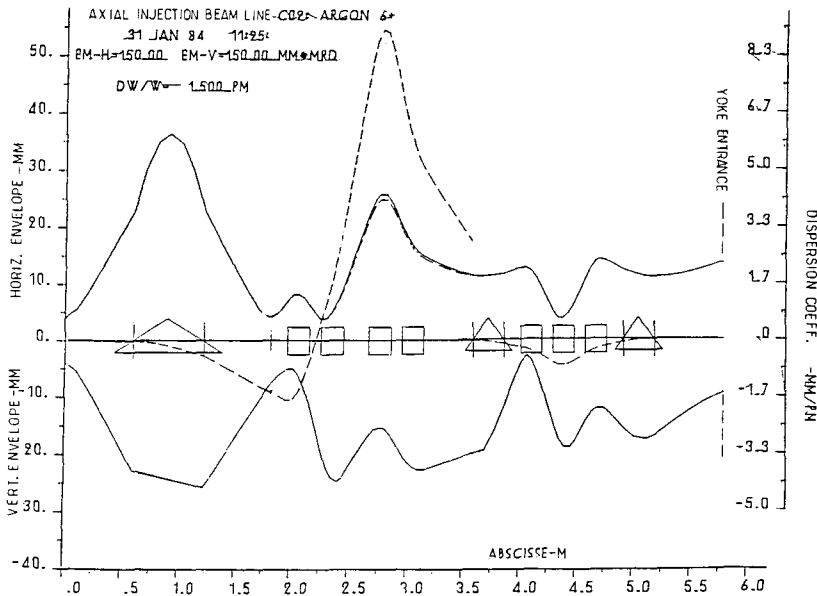

FIG 9 - Envelope calculated for a 150 π mm-mrad Ar<sup>6+</sup> beam ; BR=0.04927 T.m; ECR voltage = 17.7 kV. Beam is matched to the entrance of the yoke.