

BEAM DYNAMICS ISSUES IN THE POST ACCELERATOR FOR THE RARE ISOTOPE ION BEAMS FROM ISOL SYSTEM IN RISP

Ji-Gwang Hwang, Si-Won Jang, Yumi Lee, Eun-San Kim*
 Kyungpook National University, Daegu, Korea

Hye-Jin Kim, Bong Hyuk Choi, Ilkyoung Shin, Hyung Jin Kim, Dong-O Jeon
 Rare Isotope Science Project, Institute for Basic Science, Daejeon, Korea

Abstract

The accelerator for RISP, which is the superconducting technology based heavy ion linear accelerator construction project, is composed mainly of the driver linac for stable ion beam from an ECR ion source and post linac for unstable ion beam from an ISOL system. The post accelerator can accelerate the unstable ion beams up to 16.5 MeV/u for ^{132}Sn and 16.0 MeV/u for ^{58}Ni , which has the ratio of mass to charge, A/q , of 8.3. The unstable ion beam such as ^{132}Sn from an ISOL system has the large initial transverse and longitudinal emittances. Hence acceptance and envelope of the post accelerator should be optimized for stable operation. The beam was transported by the post-to-driver transport (P2DT) line which consists of a charge stripper, two charge selection sections and a telescope section with the bunching cavities. In this presentation, we will show the criteria for the design of the post accelerator and result of beam tracking simulation from the low energy transport line to the end of post linac. The initial coordinates of the particles were acquired by the tracking simulation from the low energy beam transport (LEBT) line to the medium energy beam transport (MEBT) line.

INTRODUCTION

The superconducting technology based heavy ion linear accelerator named as a RAON (Rare isotope Accelerator Of Newness) was launched to examine the numerous facets of basic science, such as nuclear physics, astrophysics, atomic physics, life science, medicine and material science [1]. The post accelerator of RAON, which consists of a ISOL based ion source to produce the unstable ion beams, ECR ion source to produce the stable ion beam, a low energy transport line, a RFQ accelerator, a medium energy beam transport line, and a low energy linac, produce an energy of 16.5 MeV/u for ^{132}Sn ion beams and 16.0 MeV/u for ^{58}Ni ion beams with a high repetition rate of 81.25 MHz. The schematic layout of the post linac, post-to-driver transport (P2DT) beam line and the high energy driver linac are shown in Fig. 1.

Main purpose of the post linac is to produce the high energy RI beams produced by the Isotope Separator On-Line (ISOL) system to investigate not only the structures of unstable nuclei themselves but also the exotic nuclear reactions induced by the unstable nuclei through the ex-

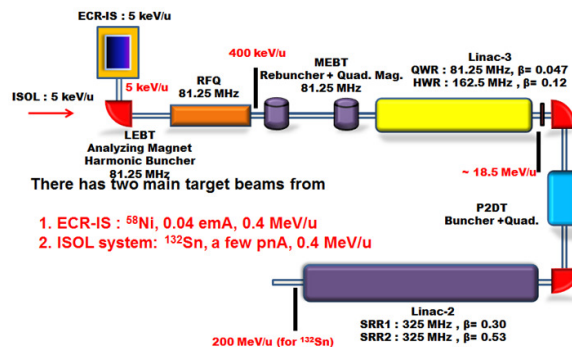

Figure 1: The schematic layout of the post linac.

periments using the RI beams [2, 3]. The optics design of post linac, however, is significant for the stable operation because the transverse emittance of the unstable ion beams produced by the ISOL system has the large emittance, ~ 0.3 mm-mrad (rms). In order to design the stable optics for the post linac, the beam dynamics study was performed.

BEAM DYNAMICS FOR POST LINAC

There are many instabilities which can cause the particle loss in the long linac such as the envelope instability, parametric resonance and the space charge effect. When the zero current phase advances, σ_0 , is smaller than 90° , the beam is always stable. Then this condition is indeed used as a design criterion for high current machines. A low phase advance per period, and consequently a smooth focusing, has some costs in terms of beam dimensions, but guarantees the stability of envelope oscillations [4].

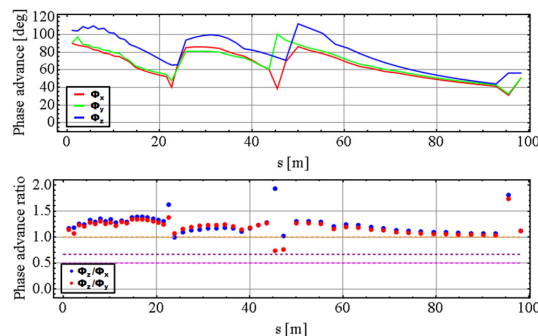

Figure 2: The zero current phase advance (top) and ration of the phase advance (bottom) in the post linac.

* eskim1@knu.ac.kr

Content from this work may be used under the terms of the CC BY 3.0 licence (© 2014). Any distribution of this work must maintain attribution to the author(s), title of the work, publisher, and DOI.

Figure 2 shows that the ratio between the zero current transverse and longitudinal phase advance, ϕ_z/ϕ_x and ϕ_z/ϕ_y , was also almost kept between 1.0 and 1.5 except the matching section to vanish the effect of the parametric resonance. In order to increase the longitudinal acceptance of the post linac, the zero current phase advance on longitudinal direction was higher than the zero current phase advance on the transverse direction. The physical dimension of the post linac is identical to a low energy linac of the driver linac [5]. Since the longitudinal acceptance in the low energy linac mainly depends on the distance between cavities in the QWR section, the length of the section was optimized to increase the longitudinal acceptance in the low energy linac by reducing the physical length of the quadrupole magnets and spaces for warm and cold section [6].

Lattice Design for ^{132}Sn Ion Beam

The phase of the RF field in the cavity was also -65° at the first cavity and it was increased up to -45° at the end of QWR section to widen the acceptance of the linac. The field gradient of the cavity was matched to smoothly vary the phase advance so long as the beam was accelerated.

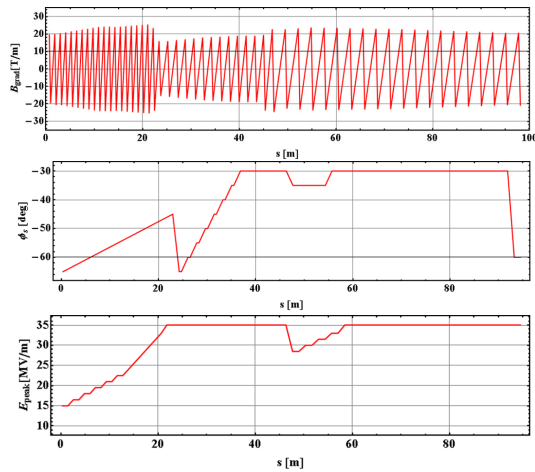

Figure 3: The strength of the quadrupole magnets(top), RF phase of the cavities (middle) and the peak electric field on the cavity surface (bottom) in the post linac.

The longitudinal acceptance in the design linac is 22 keV/u-ns that is shown in Fig. 4.

Figure 5 shows the beam envelope, and rms transverse and longitudinal emittances along the post linac. It was calculated by the multi-particle tracking simulation using code TRACK, which can compute multi-particle simulation of multiple component ion beams in 6D phase space [7].

Since the rms transverse emittance of the ^{132}Sn provided from the ISOL system is about 0.3 mm-mrad, the rms envelope in the linac is larger than 4 mm even through the beam size was minimized. Then the study for compensation of the orbit jitter due to the misalignment and strength error of the elements is important to avoid the beam loss because the physical aperture is 20 mm, which is about five times

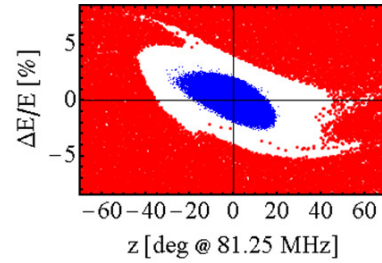

Figure 4: The longitudinal acceptance and the particle distribution of the designed post linac for ^{132}Sn ion beam.

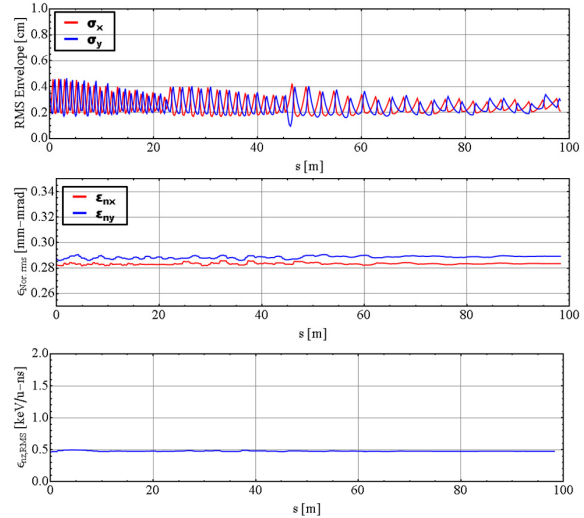

Figure 5: The envelope of the beam size(top), transverse emittance (middle) and longitudinal emittance (bottom) in the post linac.

the rms beam size. The growths of the transverse and longitudinal emittance are ignorable. The particle distribution on the 6D phase space at the end of the post linac is shown in Fig 6.

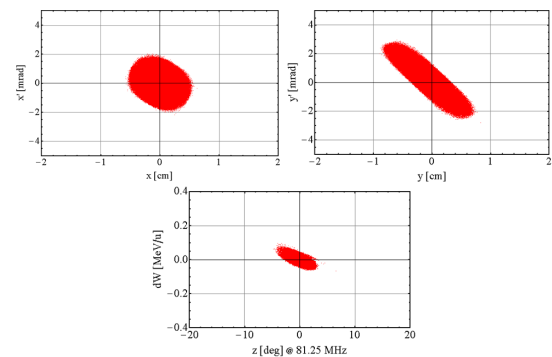

Figure 6: The particle distributions of ^{132}Sn on 6D phase space at the end of the post linac.

Lattice Design for ^{58}Ni Ion Beam

The low energy beam transport line has the multi-harmonic buncher used for the ^{58}Ni because the ^{58}Ni ion beam is produced by the ECR ion source and then the intensity is higher than the beams from ISOL system. Then the longitudinal emittance of the ^{58}Ni ion beam at the entrance of the post linac is smaller than ^{132}Sn ion beam. The phase of the RF field in the cavity was also -66° at the first cavity and it was increased up to -30° at the end of QWR section. The RF phase was more rapidly increased than the case of ^{132}Sn ion beam to increase the efficiency of the acceleration. The longitudinal acceptance in the design linac is 22 keV/u-ns that is shown in Fig. 7.

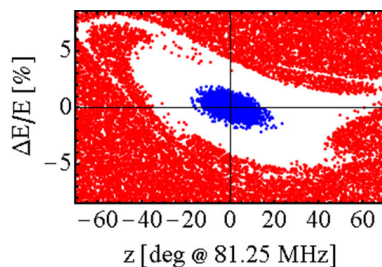

Figure 7: The longitudinal acceptance and the particle distribution of the designed post linac for ^{58}Ni ion beam.

Figure 8 shows the beam envelope and rms transverse and longitudinal emittances along the post linac. It was calculated by the multi-particle tracking simulation using code TRACK. The initial coordinates of the particles were acquired by the tracking simulation from the exit of the ECR ion source to the medium energy beam transport line. The transverse emittance at the exit of the ECR ion source is 0.2 mm-mrad and the injection energy of the ion beam is 400 keV/u.

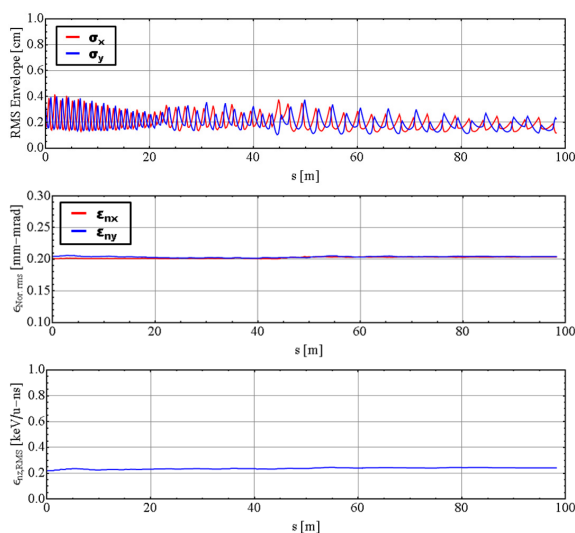

Figure 8: The envelope of the beam size (top), transverse emittance (middle) and longitudinal emittance (bottom) in the post linac.

The growths of the transverse and longitudinal emittance are ignorable. The particle distribution on the 6D phase space at the end of the post linac is shown in Fig. 9.

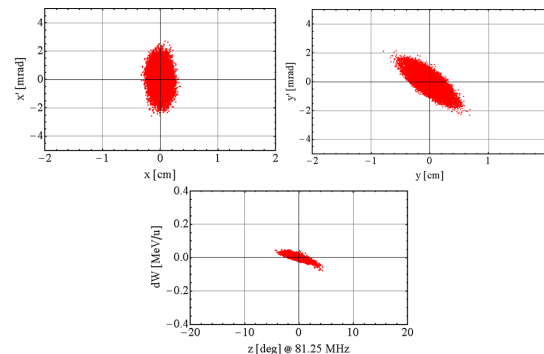

Figure 9: The particle distributions of ^{58}Ni on 6D phase space at the end of the post linac.

CONCLUSION

The beam dynamics study for designing the post linac of RAON, which is used to provide the high energy unstable ion beams produced by the ISOL system and in-flight system, was performed and lattices of the linac for ^{58}Ni ion beam and ^{132}Sn ion beam were designed. The phase advance in the designed linac was kept to avoid the envelope instability and the space charge effect. The ratio of phase advance between the transverse and longitudinal was controlled between 1 and 1.5 to avoid the parametric resonance. To widen the longitudinal acceptance of the designed linac, the phase advance on longitudinal direction was larger than the transverse phase advance and the RF phase of the cavity was set to be about -60° . Based on the multi-particle tracking simulation, the performances of the designed linac were confirmed.

REFERENCES

- [1] <http://www.ibs.re.kr>
- [2] B. H. Kang et al., Journal of Korean Physical Society, **63**, 1473 (2013).
- [3] K. Tshoo et al., Nuclear Instruments and Methods in Physics Research B, **317**, 242 (2013).
- [4] A. Pisent, INSTABILITIES IN LINEAR ACCELERATORS, CERN-2005-004 p.198.
- [5] Ji-Gwang Hwang, et al., "Beam dynamics issues for a superconducting linear accelerator-based high power heavy ion machine", THPME148, Proc. IPAC14, Dresden Germany.
- [6] A. P. Fateev and P. N. Ostromov, Nuclear Instruments and Methods in Physics Research, **222**, 420 (1984).
- [7] P. N. Ostromov and K. W. Shepard, Phys. Rev. ST. Accel. Beams, **11**, 030101 (2001).