

BEAM CURRENT MONITORS FOR FAIR*

M. Schwickert^{1#}, H. Bräuning¹, F. Kurian¹, H. Reeg¹, A. Reiter¹,
R. Geithner^{2,3}, W. Vodel², R. Neubert³

¹GSI Helmholtzzentrum für Schwerionenforschung, Darmstadt, Germany

²Helmholtz-Institute Jena, Germany

³Friedrich-Schiller-University Jena, Germany

Abstract

The FAIR (Facility for Antiproton and Ion Research) accelerator facility presently under construction at GSI will supply a wide range of beam intensities for physics experiments. Design beam intensities range from 2.5×10^{13} protons/cycle to be delivered to the pBar-target and separator for production of antiprotons, to beams of e.g. 10^9 ions/s in the case of slowly extracted beams. The large intensity range demands for dedicated beam current monitors for precise, non-destructive beam intensity measurements in the synchrotrons, transport lines and storage rings of the FAIR facility. This report describes GSI developments of purpose-built beam current monitors for the SIS100 synchrotron and high-energy beam transport lines (HEBT) of FAIR. Prototype measurements with a SQUID-based Cryogenic Current Comparator and a resonant beam charge transformer are presented, and possibilities for further upgrades are discussed.

FAIR – ACCELERATORS AND REQUIREMENTS

The FAIR accelerator complex is presently under construction at the GSI site. Existing GSI accelerators, UNILAC and SIS18, will act as an injector for the novel FAIR machines [1].

The main synchrotron of FAIR will be the fast ramped super-conducting SIS100. In the present layout SIS100 will deliver up to 4×10^{11} U^{28+} ions/s with energies of 400-2700 MeV/u, either in single bunches of 30-90 ns, or as slowly extracted beam with extraction times of several seconds, for the radioactive ion beam program of FAIR. For the production of antiprotons it is required to deliver 2.5×10^{13} protons per pulse at an energy of 29 GeV with a repetition rate of 0.2 Hz and a bunch length of 50 ns. In addition, it is foreseen that FAIR accelerators operate in a highly multiplexed mode, i.e. deliver beams to up to four different experiments inside one machine super-cycle. The various modes of operation for SIS100 demand for a high dynamic range of the intensity measurements inside SIS100 and the HEBT beam lines. Different types of beam current transformers, each designed for the special requirements of the related installation locations, are presently being developed at GSI. The Novel DC Current Transformer is planned as a versatile instrument for mid-

range to high beam intensity inside the SIS100 synchrotron. A dedicated device for the measurement of slowly extracted beams from SIS100 is the Cryogenic Current Comparator. Here the focus is on highest current sensitivity for DC beams in the nanoampere region. For the measurement of fast extracted beams Resonant Transformers are foreseen in the HEBT, where a high accuracy is required to allow for precise monitoring of particle transmission.

NOVEL DC CURRENT TRANSFORMER

In the past years studies towards a novel kind of DC current transformer (NDCCT) were performed at GSI [2]. The development of a NDCCT is motivated by well-known flaws of the present GSI-built DCT, i.e. erroneous signals for high beam currents above ~ 70 mA and for bunch frequencies around 1.2 MHz. Whereas these parameters are rarely used for the operation of the existing SIS18 synchrotron, it will be the standard operation mode for the future SIS100 synchrotron. In principle the NDCCT consists of two sensitive GMR (Giant Magneto Resistance) sensors installed in both gaps of a split ferrite toroid. The prototype setup includes a differential pre-amplifier. In a second stage the AC signal from a sense winding on the split toroid is fed to a local feedback path, thus allowing measuring also non-DC beam currents by detecting the high-frequency components within the same device. The aim is to allow for a high input bandwidth from DC beam up to several kHz. The project goal is a dynamic range of ~ 100 μ A up to 150 A at bunch frequencies up to 5 MHz. At present the Tunnelling Magneto Resistance sensor (TMR) is studied for its applicability for the NDCCT, with the advantage that no magnetic biasing of the toroid is required, due to the TMR bipolar output characteristics.

Additional performance parameters are the detrimental long-term drift of the DCT, as well as the requirement to reach a high absolute accuracy. After a first prototype setup using the GMR sensor had shown a good resolution threshold of ~ 220 μ A [3], further optimizations are ongoing, e.g. by significant improvements of the magnetic shield and the overall EMC behaviour. To enhance resolution and frequency response an integrated analog electronics board for the control loop between the two readout branches is presently in the design phase.

CRYOGENIC CURRENT COMPARATOR

The development of a high-precision online measurement system for DC beams with nA-resolution is

* Partly funded by EU-FP7 Marie-Curie ITN DITANET

Corresponding author: m.schwickert@gsi.de

Content from this work may be used under the terms of the CC BY 3.0 licence (© 2014). Any distribution of this work must maintain attribution to the author(s), title of the work, publisher, and DOI.

a long-term project at GSI since the 1990s [4]. The CCC resolution is more than two orders of magnitude below the sensitivity of the ubiquitous flux-gate DCCTs ($\sim 1 \mu\text{A}_{\text{rms}}/\sqrt{\text{Hz}}$ [5]), but is required for single-pass measurements of slowly extracted ion beams. The basic principle of the CCC is the precise detection of the azimuthal magnetic field of an ion beam passing a toroidal sensor assembly. The CCC sensor consists of a magnetic alloy toroid acting as a magnetic flux concentrator. The flux concentrator is surrounded by a superconducting pick-up coil connected to a high-precision DC-SQUID system. In order to effectively shield the flux concentrator and the pick-up coil from disturbing magnetic stray fields both are encapsulated in a meander-shaped magnetic shield, as depicted in Fig. 1.

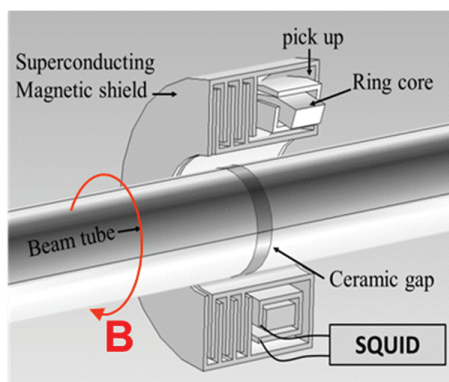

Figure 1: CCC schematic setup.

Existing CCC Prototype

In the existing CCC prototype the magnetic shield was made from lead [4] as this element becomes superconducting below 7.2 K. The DC SQUID for the readout of the pick-up coil was purpose-built at Jena University. Both, the DC SQUID and the magnetic shield require operation at 4.2 K, thus the complete sensor setup has to be installed inside a liquid helium cryostat (not shown in Fig. 2). The beam passes through two warm holes linked to the beam line vacuum system and a ceramic gap in the beam pipe prevents mirror currents from shielding the electro-magnetic field of the beam, as well as the disturbance by any stray current along the beam tube. Detailed investigations were performed to further improve the current sensitivity and frequency behaviour of the CCC setup.

Development of an Enhanced Sensor Prototype

Because the presently achieved current resolution is limited by the overall system noise, all sources of electromagnetic noise were investigated. Detailed FEM simulations were carried out to optimize the superconducting magnetic shield [6] and to increase the attenuation of disturbing non-azimuthal field components. As a consequence, the magnetic shield of the enhanced CCC sensor was fabricated from Niobium, with an increased number of meanders and a smaller gap width

between adjacent meander disks. Moreover, magnetic properties of various toroid materials at liquid Helium temperature were studied to optimize the flux concentrator. The enhanced CCC sensor includes a toroid made from nano-crystalline Nanoperm material with a very high relative permeability of 40,000 [7]. Additional studies were conducted to enhance the frequency response of the SQUID electronics and to evaluate commercially available SQUIDS for the use inside the CCC. With these upgrades a significantly increased sensitivity in the sub-nA region is expected. More details on the CCC sensor upgrades are presented in [8].

Beam Tests with Improved SQUID

The existing CCC prototype setup has recently been re-commissioned, upgraded with a new SQUID unit and tested with beam. For the beam tests the former purpose-built SQUID UJ-111 was replaced with a commercial Supracon-SQUID [9] and Magnicon readout unit [10]. The CCC setup was installed in the HEBT section behind SIS18 synchrotron. In addition, downstream of the CCC a secondary electron emission monitor (SEM) was installed to compare the measured beam intensity and spill profile. For the beam tests a Ni^{26+} beam at 600 MeV was used with intensities in the range 10^7 to 10^9 particles/spill.

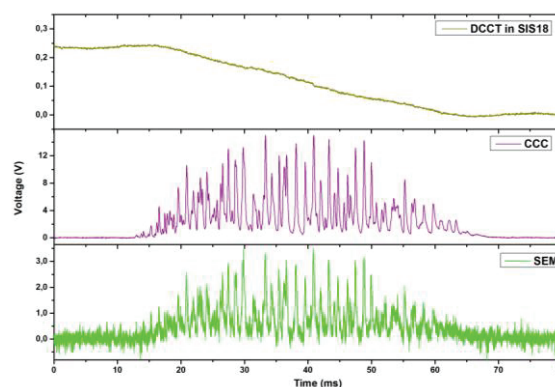

Figure 2: Slowly extracted Ni^{26+} beam measured with DCCT (top), CCC (middle) and SEM (bottom).

Figure 2 shows an exemplary measurement of a DCCT installed inside the synchrotron (top), the CCC signal (mid) and SEM signal (bottom). During slow extraction of the beam the signal of the DCCT inside SIS18 decreases and both, CCC and SEM show an identical spill structure of the 50 ms spill.

In order to prove the linear response of the SQUID readout to the applied beam current the mean current as measured with the SEM and CCC is plotted in Fig. 3.

First beam tests with the upgraded CCC prototype have shown that the spill shape as measured with the SEM is exactly reproduced by the CCC, and the CCC current signal displays very good linearity to the SEM output signal. The SQUID upgrade resulted in a significantly improved current resolution, a preliminary evaluation yields $\sim 0.2 \text{ nA}$ ($S/N=1$).

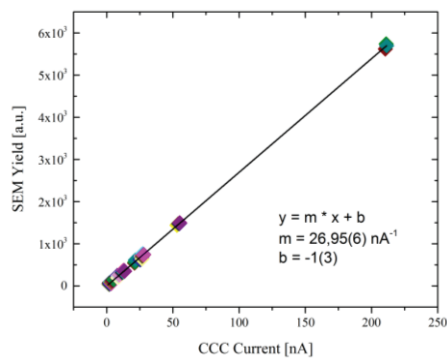

Figure 3: SEM signal as function of beam current measured with the CCC (note the small error of slope m).

RESONANT BEAM CHARGE TRANSFORMER

For standard online beam current measurement of fast extracted beams in the HEBT section Resonant Transformers (RT) are foreseen. At present, the RT is the most sensitive device for non-intercepting intensity measurements of fast extracted beams. The basic principle is that a particle bunch excites a damped oscillation inside the RT electronic circuit. The amplitude of each oscillation maximum is directly proportional to the total bunch charge. In the RT instruments presently used at GSI a peak detector samples the amplitude of the second maximum and typically a resolution of ~ 10 pC_{RMS} (i.e. 6×10^7 protons) has been achieved. For high current operation however, the resolution drops to 100 nC (6×10^{11} protons), insufficient for transmission control or interlocks. Because the peak detector is prone to any noise contribution at the selected oscillation maximum, a more sophisticated post analysis of the oscillation is performed in software. Previous studies have shown that an improvement of the RT sensitivity by one order of magnitude could be achieved by omitting the peak detector and recording instead the complete oscillation with a high-resolution ADC [3].

Precise baseline correction of the raw RT signal is important since any offset directly affects the amplitude of the maxima. Moreover, all oscillation parameters, like resonant frequency ω_0 and decay time constant λ , are fixed by hardware, i.e. the LCR equivalent circuit [11]. With these parameters the evaluation of the total beam pulse charge can be derived from a straightforward envelope-fit of a number of distinct maxima, thus improving the overall RT sensitivity and resolution. In addition, by applying an adequate FFT filter, offset correction and flexible noise filtering is achieved. The algorithm consists of the following steps: adequate FFT filtering including offset correction, identification of maxima and minima until a pre-set threshold for signal-to-noise is crossed, application of a robust estimator of the exponential decay curve and finally evaluation of the amplitude, which is proportional to the total beam pulse charge. Figure 4 presents the raw RT signal (top) and post-processed data (bottom), of 10^6 Kr³³⁺ ions at 300 MeV/u.

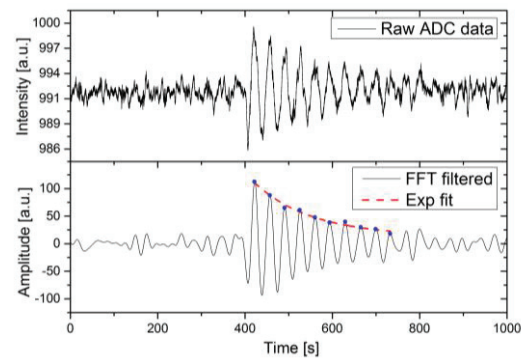

Figure 4: Raw RT signal (top) and post-processed data (bottom), see text.

Future goal of the RT development is to achieve 1-2% absolute accuracy by inserting an in-situ calibration generator. Subsequent RTs have to be well adjusted e.g. for transmission control, by use of the calibration generator. For certain HEBT beam lines operation with 10^{12} U²⁸⁺ ions is foreseen, thus the RT electronics must be capable of up to 10 μ C input charge. Hence, with respect to the RT's design parameters the electronic front-end has to cope with up to 100 V_{pp}. In consequence, an upgraded version is under development with an increased sensitivity as required for sections behind FAIR production targets with relatively low particle numbers.

CONCLUSION

For the wide range of beam intensities at FAIR purpose-built beam current monitors are developed at GSI. First tests with the NDCCT for synchrotron installation show a good resolution threshold at high bandwidth. In first beam tests the upgraded CCC proved good reproduction of the spill structure, and improved current resolution in the sub-nanoampere range. To optimize the absolute accuracy of the RT a sophisticated post-processing shows promising results.

REFERENCES

- [1] <http://www.fair-center.eu>
- [2] A. Schlörit, H. Reeg, GSI Scientific Report 2008, p. 94, Darmstadt, Germany (2009).
- [3] M. Schwickert et al., Proc. IPAC 2012, New Orleans (LA), US, MOPPR013, p.801 (2012).
- [4] A. Peters et al., Proc. BIW 1998, Stanford (CA), US, p.163 (1998).
- [5] Bergoz Instrumentation, http://www.bergoz.com/index.php?option=com_content&view=article&id=35&Itemid=48
- [6] F. Kurian et al., Proc. BIW 2012, Newport News (VA), US, MOPG001, p. 1 (2012).
- [7] R. Geithner et al., Cryogenics 54, p. 16 (2013).
- [8] R. Geithner et al., THPME122, these proceedings.
- [9] <http://www.supracon.com/de/squid.html>
- [10] <http://www.magnicon.com/squid-electronics/>
- [11] M.A. Clarke-Gayther, Proc. EPAC 1996, Sitges, Spain, TUP079L, p. 1713 (1996).